

Kawasaki GPz400/550

Z400F/F-II

Z500F

Z550F



**Motorcycle
Service Manual
Supplement**

Quick Reference Guide

To use, bend the manual back and match the desired chapter below against the black spot showing at the edge of these pages.



General Information	1	
Scheduled Maintenance	2	
Non - scheduled Maintenance	Engine	3
	Chassis	4
	Electrical	5
Disassembly	Engine	6
	Chassis	7
Appendix	8	
Supplement - 1984 Model	9	
Supplement - 1985 Model	10	
Supplement - 1986-1988 Models	11	
Supplement - 1991 Model	12	

SAFETY AWARENESS

Whenever you see the symbols shown below, heed their instructions! Always follow safe operating and maintenance practices.

WARNING

○This warning symbol identifies special instructions or procedures which, if not correctly followed, could result in personal injury, or loss of life.

CAUTION

○This caution symbol identifies special instructions or procedures which, if not strictly observed, could result in damage to or destruction of equipment.

"NOTE"

○This note symbol indicates points of particular interest for more efficient and convenient operation.

LIST OF ABBREVIATIONS

A	ampere(s)	lb	pound(s)
ABDC	after bottom dead center	m	meter(s)
AC	alternating current	min	minute(s)
ATDC	after top dead center	N	newton(s)
BBDC	before bottom dead center	Pa	pascal(s)
BDC	bottom dead center	PS	horsepower
BTDC	before top dead center	psi	pound(s) per square inch
°C	degree(s) Celsius	r	revolution
DC	direct current	rpm	revolution(s) per minute
F	farad(s)	TDC	top dead center
°F	degree(s) Fahrenheit	TIR	total indicator reading
ft	foot, feet	V	volt(s)
g	gram(s)	W	watt(s)
h	hour(s)	Ω	ohm(s)
L	liter(s)		

Read OWNER'S MANUAL before operating

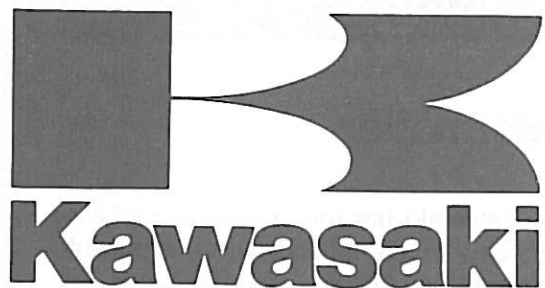

Z400F/F-II
Z500F
Z550F
GPz400/550

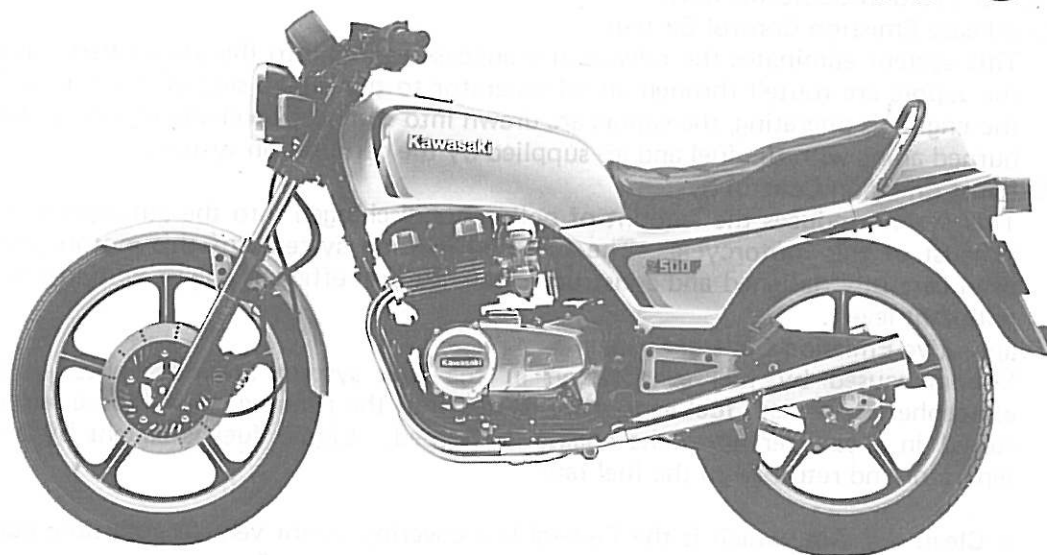

Motorcycle Service Manual Supplement

All rights reserved. No parts of this publication may be reproduced, stored in a retrieval system, or transmitted in any form or by any means, electronic mechanical photocopying, recording or otherwise, without the prior written permission of Quality Assurance Department/Consumer Products & Components Group/ Kawasaki Heavy Industries, Ltd., Japan.

No liability can be accepted for any inaccuracies or omissions in this publication, although every possible care has been taken to make it as complete and accurate as possible.

The right is reserved to make changes at any time without prior notice and without incurring an obligation to make such changes to products manufactured previously. See your Motorcycle dealer for the latest information on product improvements incorporated after this publication.

All information contained in this publication is based on the latest product information available at the time of publication. Illustrations and photographs in this publication are intended for reference use only and may not depict actual model component parts.

Emission Control Information

To protect the environment in which we all live, Kawasaki has incorporated crankcase emission (1) and exhaust emission (2) control systems in compliance with applicable regulations of the United States Environmental Protection Agency and California Air Resources Board. Additionally, Kawasaki has incorporated an evaporative emission control system (3) in compliance with applicable regulations of the California Air Resources Board on vehicles sold in California only.

1. Crankcase Emission Control System

This system eliminates the release of crankcase vapors into the atmosphere. Instead, the vapors are routed through an oil separator to the intake side of the engine. While the engine is operating, the vapors are drawn into combustion chamber, where they are burned along with the fuel and air supplied by the carburetion system.

2. Exhaust Emission Control System

This system reduces the amount of pollutants discharged into the atmosphere by the exhaust of this motorcycle. The fuel and ignition systems of this motorcycle have been carefully designed and constructed to ensure an efficient engine with low exhaust pollutant levels.

3. Evaporative Emission Control System

Vapors caused by fuel evaporation in the fuel system are not vented into the atmosphere. Instead, fuel vapors are routed into the running engine to be burned, or stored in a canister when the engine is stopped. Liquid fuel is caught by a vapor separator and returned to the fuel tank.

The Clean Air Act, which is the Federal law covering motor vehicle pollution, contains what is commonly referred to as the Act's "tampering provisions."

"Sec. 203(a) The following acts and the causing thereof are prohibited...

(3)(A) for any person to remove or render inoperative any device or element of design installed on or in a motor vehicle or motor vehicle engine in compliance with regulations under this title prior to its sale and delivery to the ultimate purchaser, or for any manufacturer or dealer knowingly to remove or render inoperative any such device or element of design after such sale and delivery to the ultimate purchaser.

(3)(B) for any person engaged in the business of repairing, servicing, selling, leasing, or trading motor vehicles or motor vehicle engines, or who operates a fleet of motor vehicles knowingly to remove or render inoperative any device or element of design installed on or in a motor vehicle or motor vehicle engine in compliance with regulations under this title following its sale and delivery to the ultimate purchaser..."

"NOTE"

○The phrase "remove or render inoperative any device or element of design" has been generally interpreted as follows:

1. Tampering does not include the temporary removal or rendering inoperative of devices or elements of design in order to perform maintenance.
2. Tampering could include:
 - a. Maladjustment of vehicle components such that the emission standards are exceeded.
 - b. Use of replacement parts or accessories which adversely affect the performance or durability of the motorcycle.
 - c. Addition of components or accessories that result in the vehicle exceeding the standards.
 - d. Permanently removing, disconnecting, or rendering inoperative any component or element of design of the emission control systems.

WE RECOMMEND THAT ALL DEALERS OBSERVE THESE PROVISIONS OF FEDERAL LAW, THE VIOLATION OF WHICH IS PUNISHABLE BY CIVIL PENALTIES NOT EXCEEDING \$10,000 PER VIOLATION.

TAMPERING WITH NOISE CONTROL SYSTEM PROHIBITED

Federal law prohibits the following acts or the causing thereof:

- (1) The removal or rendering inoperative by any person other than for purposes of maintenance, repair, or replacement, of any device or element of design incorporated into any new vehicle for the purpose of noise control prior to its sale or delivery to the ultimate purchaser or while it is in use, or (2) the use of the vehicle after such device or element of design has been removed or rendered inoperative by any person.

Among those acts presumed to constitute tampering are the acts listed below:

- Replacement of the original exhaust system or muffler with a component not in compliance with Federal regulations.
- Removal of the muffler(s) or any internal portion of the muffler(s).
- Removal of the air box or air box cover.
- Modifications to the muffler(s) or air intake system by cutting, drilling, or other means if such modifications result in increased noise levels.

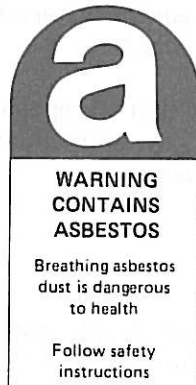

This warning may apply to any of the following components or any assembly containing one or more of these components:—

Brake Shoes or Pads
Clutch Friction Material
Gaskets
Insulators

SAFETY INSTRUCTIONS

- Operate if possible out of doors or in a well ventilated place.
- Preferably use hand tools or low speed tools equipped, if necessary, with an appropriate dust extraction facility. If high speed tools are used, they should always be so equipped.
- If possible, dampen before cutting or drilling.
- Dampen dust and place it in properly closed receptacle and dispose of it safely.

Foreword

This Service Manual Supplement is designed to be used in conjunction with the KZ400/KZ500/KZ550 Motorcycle Service Manual, P/N 99924-1018-05 (or 04). The maintenance and repair procedures described in this Supplement are only those that are unique to the models listed on the back cover. Most service operations for these models remain identical to those described in the Base Manual. Complete and proper servicing of the models listed on the back cover therefore requires both this Supplement and the Base Manual.

This Service Manual Supplement is designed primarily for use by motorcycle mechanics in a properly equipped shop, although it contains enough detail and basic information to make it useful to the motorcycle user who desires to carry out his own basic maintenance and repair work. Since a certain basic knowledge of mechanics, the proper use of tools, and workshop procedures must be understood in order to carry out maintenance and repair satisfactorily; the adjustments, maintenance, and repair should be carried out only by qualified mechanics whenever the owner has insufficient experience, or has doubts as to his ability to do the work, so that the motorcycle can be operated safely. If proper adjustment can not be obtained by following the procedures in this text, find out the cause and correct as necessary.

In order to perform the work efficiently and to avoid costly mistakes, the mechanic should read the text, thoroughly familiarizing himself with the procedures before starting work, and then do the work carefully in a clean area. Whenever special tools or equipment is specified, makeshift tools or equipment should not be used. Precision measurements can only be made if the proper instruments are used, and the use of substitute tools may adversely affect safe operation of the motorcycle.

This manual consists of the following major chapters:

1. "General Information" contains general information which will be useful when servicing the motorcycle.
2. "Scheduled Maintenance" gives the procedures for all maintenance which must be done periodically.
3. "Non-scheduled Maintenance" describes the procedures for inspection, adjustment, and repair which may become necessary unexpectedly or irregularly.
4. "Disassembly" gives teardown sequences required to service most major components. Unless specific instructions are given for assembly and installation, they are performed by reversing the removal/disassembly sequences.
5. "Appendix" in the back of this manual contains miscellaneous information, including an additional considerations for racing, troubleshooting guide, and unit conversion table.

"NOTE"

○ *Explanation on major changes and additions, that are unique to later year units since the publication of the Service Manual, will be added in the end of the text as "Supplements."*

For the duration of your warranty period, especially, we recommend that all repairs and scheduled maintenance be performed in accordance with this service manual. Any owner maintenance or repair procedure not performed in accordance with this manual may void the warranty.

To get the longest life out of your Motorcycle:

- Follow the Periodic Maintenance Chart in the Service Manual.
- Be alert for problems and non-scheduled maintenance.
- Use proper tools and genuine Kawasaki Motorcycle parts. Special tools, gauges, and testers that are necessary when servicing Kawasaki motorcycles are introduced by the Special Tool Catalog. Genuine parts provided as spare parts are listed in the Parts Catalog.
- Follow the procedures in this manual carefully. Don't take shortcuts.
- Remember to keep complete records of maintenance and repair with dates and any new parts installed.

General Information

Table of Contents



Before Servicing	1-2
Model Identification	1-4
Specifications (ZR400)	1-5
Specifications (ZR500/550)	1-7
Setting Before Ride	1-9
Service Data	1-12
Torque and Locking Agent	1-17
Special Tools	1-21
Wiring Diagram	1-27

Before Servicing

Before starting to service a motorcycle, careful reading of the applicable section is recommended to eliminate unnecessary work. Photographs, diagrams, notes, cautions, warnings, and detailed descriptions have been included wherever necessary. Nevertheless, even a detail account has limitations, a certain amount of basic knowledge is also required for successful work.

Especially note the following:

- (1) **Dirt**

Before removal and disassembly, clean the motorcycle. Any dirt entering the engine or other parts will work as an abrasive and shorten the life of the motorcycle. For the same reason, before installing a new part, clean off any dust or metal fillings.
- (2) **Battery Ground**

Remove the ground (—) lead from the battery before performing any disassembly operations on the motorcycle. This prevents:

 - (a) the possibility of accidentally turning the engine over while partially disassembled.
 - (b) sparks at electrical connections which will occur when they are disconnected.
 - (c) damage to electrical parts.
- (3) **Tightening Sequence**

Generally, when installing a part with several bolts, nuts, or screws, they should all be started in their holes and tightened to a snug fit. Then tighten them evenly in a cross pattern. This is to avoid distortion of the part and/or causing gas or oil leakage. Conversely when loosening the bolts, nuts, or screws, first loosen all of them by about a quarter of turn and then remove them. Where there is a tightening sequence indication in this Service Manual, the bolts, nuts, or screws must be tightened in the order and method indicated.
- (4) **Torque**

The torque values given in this Service Manual should always be adhered to. Either too little or too much torque may lead to serious damage. Use a good quality, reliable torque wrench.
- (5) **Force**

Common sense should dictate how much force is necessary in assembly and disassembly. If a part seems especially difficult to remove or install, stop and examine what may be causing the problem. Whenever tapping is necessary, tap lightly using a wooden or plastic-faced mallet. Use an impact driver for screws (particularly for the removal of screws held by a locking agent) in order to avoid damaging the screw heads.
- (6) **Edges**

Watch for sharp edges, especially during major engine disassembly and assembly. Protect your hands with gloves or a piece of thick cloth when lifting the engine or turning it over.
- (7) **High Flash-point Solvent**

A high flash-point solvent is recommended to reduce fire danger. A commercial solvent commonly available in North America is Stoddard solvent (generic name). Always follow manufacturer and container directions regarding the use of any solvent.
- (8) **Gasket, O-Ring**

Do not reuse a gasket or O-ring once it has been in service. The mating surfaces around the gasket should be free of foreign matter and perfectly smooth to avoid oil or compression leaks.
- (9) **Liquid Gasket, Non-permanent Locking Agent**

Follow manufacturer's directions for cleaning and preparing surfaces where these compounds will be used. Apply sparingly. Excessive amounts may block engine oil passages and cause serious damage. An example of a non-permanent locking agent commonly available in North America is Loctite Lock'n Seal (Blue).
- (10) **Press**

A part installed using a press or driver, such as a wheel bearing, should first be coated with oil on its outer or inner circumference so that it will go into place smoothly.
- (11) **Ball Bearing**

When installing a ball bearing, the bearing race which is affected by friction should be pushed by a suitable driver. This prevents severe stress on the balls and races, and prevents races and balls from being dented. Press a ball bearing until it stops at the stop in the hole or on the shaft.

(12) Oil Seal and Grease Seal

Replace any oil or grease seals that were removed with new ones, as removal generally damages seals.

When pressing in a seal which has manufacturer's marks, press it in with the marks facing out. Seals should be pressed into place using a suitable driver, which contacts evenly with the side of seal, until the face of the seal is even with the end of the hole.

(13) Seal Guide

A seal guide is required for certain oil or grease seals during installation to avoid damage to the seal lips. Before a shaft passes through a seal, apply a little oil, preferably high temperature grease on the lips to reduce rubber to metal friction.

(14) Circlip, Retaining Ring

Replace any circlips and retaining rings that were removed with new ones, as removal weakens and deforms them. When installing circlips and retaining rings, take care to compress or expand them only enough to install them and no more.

(15) Lubrication

Engine wear is generally at its maximum while the engine is warming up and before all the rubbing surfaces have an adequate lubricative film. During assembly, oil or grease (whichever is more suitable) should be applied to any rubbing surface which has lost its lubricative film. Old grease and dirty oil should be cleaned off. Deteriorated grease has lost its lubricative quality and may contain abrasive foreign particles.

Don't use just any oil or grease. Some oils and greases in particular should be used only in certain applications and may be harmful if used in an application for which they are not intended. This manual makes reference to molybdenum disulfide grease (MoS₂) in the assembly of certain engine and chassis parts. Always check manufacturer recommendations before using such special lubricants.

(16) Electrical Wires

All the electrical wires are either single-color or two-color and, with only a few exceptions, must be connected to wires of the same color. On any of the two-color wires there is a greater amount of one color and a lesser amount of a second color, so a two-color wire is identified by first the primary color and then the secondary color. For example, a yellow wire with thin red stripes is referred to as a "yellow/red" wire; it would be a "red/yellow" wire if the colors were reversed to make red the main color.

182100

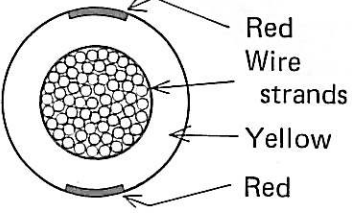
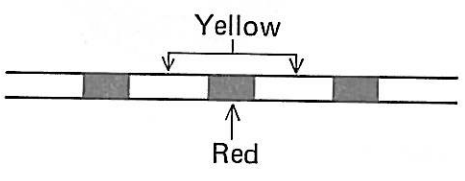
Wire (cross-section)	Name of Wire Color	Picture in Wiring Diagram
 <p>Red Wire strands Yellow Red</p>	Yellow/red	 <p>Yellow Red</p>

(17) Replacement Parts

When there is a replacement instruction, replace these parts with new ones every time they are removed. These replacement parts will be damaged or lose their original function once removed.

(18) Inspection

When parts have been disassembled, visually inspect these parts for following conditions or other damage. If there is any doubt as to the condition of them, replace them with new ones.

- | | | | |
|--------------|---------------|-----------|------|
| Abrasion | Crack | Hardening | Warp |
| Bent | Dent | Scratch | Wear |
| Color change | Deterioration | Seizure | |

(19) Service Data

Numbers of service data in this text have following meanings:

"Standards": Show dimensions or performances which brand-new parts or systems have.

"Service Limits": Indicate the usable limits. If the measurement shows excessive wear or deteriorated performance, replace the damaged parts.

.....
Model Identification
.....

ZR400-A1

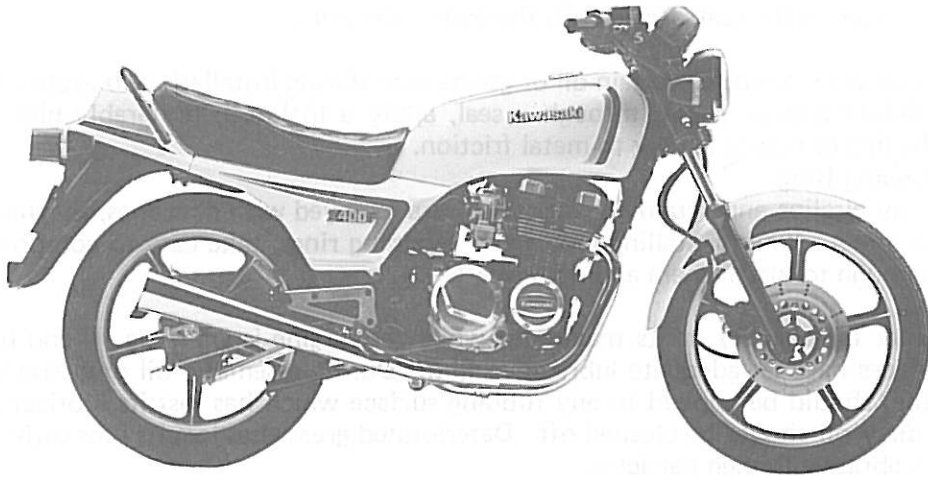

ZR500-A1



ZR550-A1

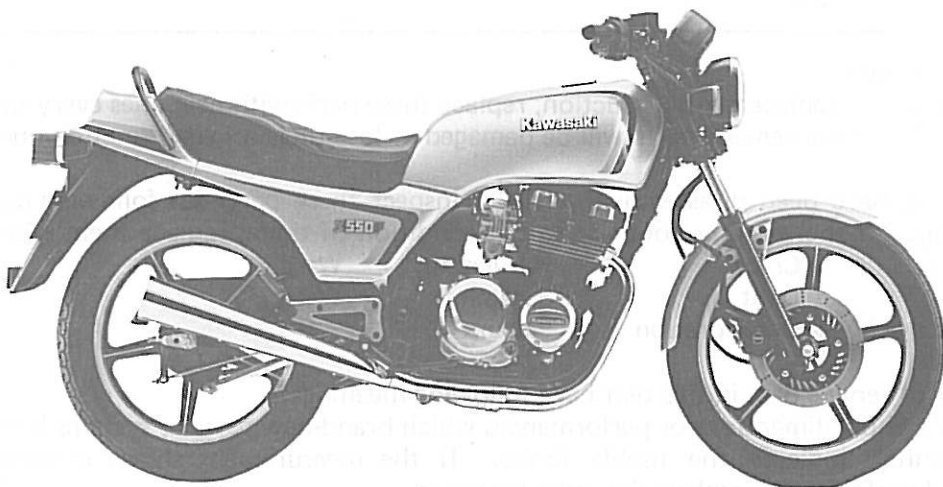

.....
Specifications (ZR400)

Items	ZR400-A1
Dimensions:	
Overall length	2,235 mm (S) 2,170 mm
Overall width	750 mm
Overall height	1,105 mm
Wheelbase	1,450 mm
Road clearance	160 mm
Seat height	795 mm
Dry weight	1,765 N (180 kg) (S) 1,775 N (181 kg)
Curb weight:	
Front	922 N (94 kg)
Rear	1,010 N (103 kg) (S) 1,020 N (104 kg)
Fuel tank capacity	18.5 L
Performance:	
Climbing ability	30°
Braking distance	12.5 m from 50 km/h
Minimum turning radius	2.5 m
Engine:	
Type	4 stroke, DOHC, 4-cylinder
Cooling system	Air cooled
Bore and stroke	52.0 x 47.0 mm
Displacement	399 mL
Compression ratio	9.7
Maximum horsepower	35.3 kW (48 PS) @10,500 r/min (rpm)
Maximum torque	34.3 N-m (3.5 kg-m, 25.3 ft-lb) @8,500 r/min (rpm)
Carburetion system	Carburetors, TK K26 V x 4
Starting system	Electric starter
Ignition system	Battery and coil (transistorized)
Timing advance	Mechanically advanced
Ignition timing	From 15° BTDC @1,200 r/min (rpm) to 40° BTDC @3,200 r/min (rpm)
Spark plug	NGK DR8ES or ND X24ESR-U (S) NGK D8EA or ND X24ES-U
Cylinder numbering method	Left to right, 1-2-3-4
Firing order	1-2-4-3
Valve timing:	
Inlet	Open 36° BTDC
	Close 44° ABDC
	Duration 260°
Exhaust	Open 54° BBDC
	Close 26° ATDC
	Duration 260°

(Continued on next page.)

Items	ZR400-A1
Lubrication system Engine oil: Grade Viscosity Capacity	Forced lubrication (wet sump) SE class SAE10W40, 10W50, 20W40, or 20W50 3.0 L
Drive Train: Primary reduction system: Type Reduction ratio Clutch type Transmission: Type Gear ratios: 1st 2nd 3rd 4th 5th 6th Final drive system: Type Reduction ratio Overall drive ratio	Chain 3.277 (27/23 x 67/24) Wet multi disc 6-speed, constant mesh, return shift 2.571 (36/14) 1.777 (32/18) 1.380 (29/21) 1.125 (27/24) 0.961 (25/26) 0.851 (23/27) Chain drive 2.500 (40/16) 6.979 @Top gear
Frame: Type Caster (rake angle) Trail Front Tire: Type Size Rear Tire: Type Size Front suspension: Type Wheel travel Rear suspension: Type Wheel travel Brake type: Front Rear	Tubular, double cradle 27° 105 mm Tubeless 90/90-19 52S Tubeless 110/90-18 61S Telescopic fork (pneumatic) 175 mm Swing arm (uni-trak) 140 mm Dual disc Drum
Electrical Equipment: Battery Headlight: Type Bulb Tail/brake light Alternator: Type Rated output Voltage regulator:	12 V 10 AH Semi-Sealed beam 12 V 60/55 W (quartz-halogen) 12 V 5/21 W x 2 (S) 12 V 8/27 W x 2 Three-phase AC 18.5 A @10.000 r/min (rpm), 14 V Short-circuit type

Specifications subject to change without notice,
and may not apply to every country.

Ⓢ: South African Model

.....
Specifications (ZR500/550)

Items	ZR500-A1	ZR550-A1
Dimensions:		
Overall length	2,235 mm	2,235 mm (S) 2,170 mm
Overall width	750 mm	*
Overall height	1,105 mm	*
Wheelbase	1,450 mm	*
Road clearance	160 mm	*
Seat height	795 mm	*
Dry weight	1,807 N (184 kg)	*
Curb weight: Front	932 N (95 kg)	*
Rear	1,020 N (104 kg)	1,020 N (104 kg)
Fuel tank capacity	18.5 L	(S) 1,030 N (105 kg) *
Performance:		
Climbing ability	30°	*
Braking distance	12.5 m from 50 km/h	*
Minimum turning radius	2.5 m	*
Engine:		
Type	4-stroke, DOHC, 4-cylinder	*
Cooling system	Air cooled	*
Bore and stroke	55.0 x 52.4 mm	58.0 x 52.4 mm
Displacement	497 mL	553 mL
Compression ratio	9.5	*
Maximum horsepower	39.7 kW (54.0 PS) @9,500 r/min (rpm)	41.2 kW (56.0 PS) @9,000 r/min (rpm) (WG) 36.8 kW (50.0 PS) @8,500 r/min (rpm)
Maximum torque	44.1 N-m (4.5 kg-m, 32.5 ft-lb) @8,000 r/min (rpm)	48.1 N-m (4.9 kg-m, 35.4 ft-lb) @7,500 r/min (rpm) (WG) 46.1 N-m (4.7 kg-m, 34.0 ft-lb) @7,000 r/min (rpm)
Carburetion system	Carburetors, TK K26V x 4	*
Starting system	Electric starter	*
Ignition system	Battery and coil (transistorized)	*
Timing advance	Mechanically advanced	*
Ignition timing	From 10° BTDC @1,050 r/min (rpm) to 35° BTDC @3,200 r/min (rpm)	*
Spark Plug	NGK DR8ES or ND X24ESR-U	NGK DR8ES or ND X24ESR-U (S) NGK D8EA or ND X24ES-U
Cylinder numbering method	Left to right, 1-2-3-4	*
Firing order	1-2-4-3	*
Valve timing:		
Inlet	Open	20° BTDC
	Close	48° ABDC
	Duration	248°
Exhaust	Open	48° BBDC
	Close	20° ATDC
	Duration	248°

(Continued on next page.)

Items	ZR500-A1	ZR550-A1
Lubrication system	Forced lubrication (wet sump)	*
Engine oil:		
Grade	SE class	*
Viscosity	SAE 10W40, 10W50, 20W40, or 20W50	*
Capacity	3.0 L	*
Drive Train:		
Primary reduction system:		
Type	Chain	*
Reduction ratio	2.934 (27/23 x 65/26)	*
Clutch type	Wet multi disc	*
Transmission:		
Type	6-speed, constant mesh, return shift	*
Gear ratios: 1st	2.571 (36/14)	*
2nd	1.777 (32/18)	*
3rd	1.380 (29/21)	*
4th	1.125 (27/24)	*
5th	0.961 (25/26)	*
6th	0.851 (23/27)	*
Final drive system:		
Type	Chain drive	*
Reduction ratio	2.375 (38/16)	*
Overall drive ratio	5.937 @Top gear	*
Frame:		
Type	Tubular, double cradle	*
Caster (rake angle)	27.5°	*
Trail	110 mm	*
Front Tire:		
Type	Tubeless	*
Size	3.25H-19 4PR	*
Rear Tire:		
Type	Tubeless	*
Size	4.00H-18 4PR	*
Front suspension:		
Type	Telescopic fork (pneumatic)	*
Wheel travel	175 mm	*
Rear suspension:		
Type	Swing arm (uni-trak)	*
Wheel travel	140 mm	*
Brake type:		
Front	Dual disc	*
Rear	Drum	*
Electrical Equipment:		
Battery	12 V 12 AH	*
Headlight:		
Type	Semi-Sealed beam	*
Bulb	12 V 60/55 W (quartz-halogen)	*
Tail/brake light	12 V 5/21 W x 2	*
Alternator:		
Type	Three-phase AC	*
Rated output	18.5 A @10,000 r/min (rpm), 14 V	*
Voltage regulator:	Short-circuit type	*

* : The same data as ZR500-A1's

Ⓢ : South African model

ⓂG : Garman model

Specifications subject to change without notice,
and may not apply to every country.

Setting Before Ride

Before bringing this motorcycle into use, check and/or adjust the followings to ensure safe and comfortable riding conditions.

Brake Pedal Position

Brake pedal position is important factor for safe and comfortable riding.

Inspection of Brake Pedal Position

- Measure the height difference between the tops of the footpeg and the pedal.
- ★ If the pedal position is not within the limit, adjust it.

Brake Pedal Position

0 – 30 mm below from the top of the footpeg

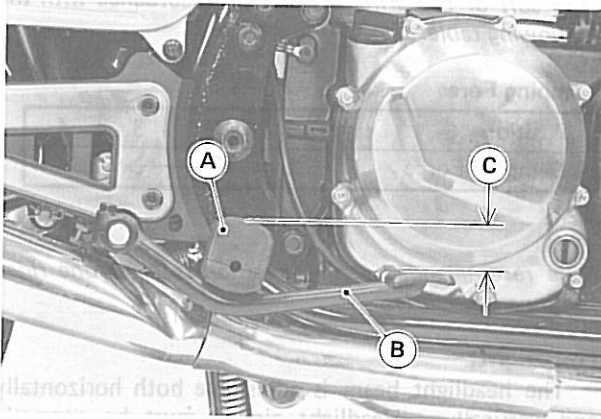

A. Footpeg C. Pedal position
B. Brake pedal

Adjustment of Brake Pedal Position

- Loosen the brake pedal adjusting bolt locknut.
- Turn the adjusting bolt to obtain the correct pedal position, and tighten the locknut.
- Check the brake pedal travel.
- Check the rear brake light switch operation.

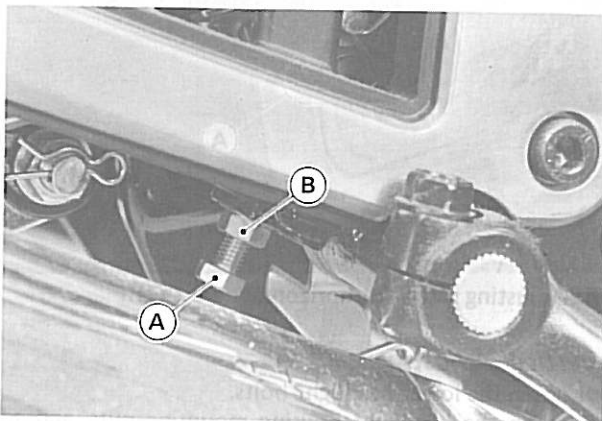

A. Adjusting bolt B. Locknut

Tires:

Failure to maintain proper inflation pressures or observe payload limits for your tires may adversely affect handling and performance of your motorcycle and can result in loss of control.

Inspection of Tire Air Pressure

- Measure the tire pressure when the tires are cold (that is, when the motorcycle has not been ridden more than a mile during the past 3 hours).
- Tire pressure is affected by changes in ambient temperature and altitude, and so the tire pressure should be checked and adjusted when your riding involves wide variations in temperature or altitude.

Tire Air Pressure (when cold)

Front	196 kPa (2.0 kg/cm ² , 28 psi)	
Rear	Up to 956 N (97.5 kg, 215 lb) load	221 kPa (2.25 kg/cm ² 32 psi)
	956 – 1,618 N (97.5 – 165 kg, 215 – 364 lb) load	221 kPa (2.25 kg/cm ² , 32 psi)

Front Fork:

The air in the front fork must be pressurized correctly for safe and comfortable riding.

Inspection of Front Fork Air Pressure

- Put the motorcycle on its center stand, and raise the front wheel off the ground using a jack under the engine.
- Use the air pressure gauge (special tool) specially made for air suspensions.
- Check and adjust the air pressure when the front fork is cold (room temperature).

"NOTE"

- Do not use a tire gauge for checking air suspension's air pressure. They do not indicate the correct pressure because of air leaks that occur when the gauge is applied to the valve.
- Lower air pressure is for comfortable riding, but it should be increased for high speed riding, or riding on bad roads.

CAUTION

○Inject air little by little so that air pressure does not rise rapidly. Air pressure exceeding 245 kPa (2.50 kg/cm², 36 psi) may damage the oil seal.

WARNING

- Be sure to adjust the air pressure within the usable range. Pressure too high or too low can produce a hazardous riding condition.
- Only air or nitrogen gas can be used. Never inject oxygen or any kind of explosive gas.
- Do not incinerate the front fork.
- Do not remove the springs and rely on compressed air only. Correct springs must be used in this suspension system. Use without springs can lead to a condition causing accident and injury.

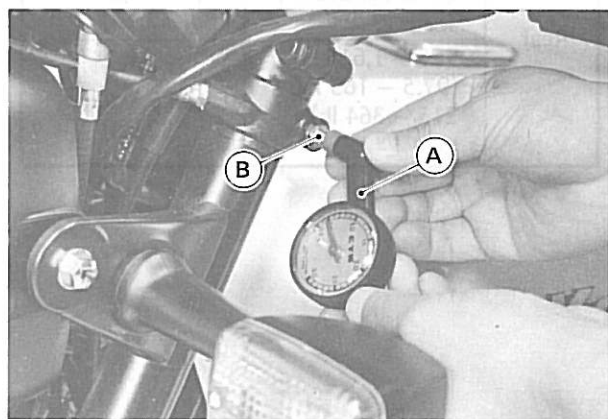

A. Air pressure gauge: 52005-1003
B. Air valve

Front Fork Air Pressure

Standard:	69 kPa (0.70 kg/cm ² , 10.0 psi)
Usable Range:	59 – 78 kPa (0.60 – 0.80 kg/cm ² , 8.5 – 11 psi)

Rear Shock Absorber:

The damper adjuster on the rear shock absorber has 4 positions so that the damping force can be adjusted for different road and loading conditions.

Adjustment of Damping Force

- Slide the dust cover out of the bottom of the shock absorber spring.
- Turn the damper adjuster to the desired position until you feel a click.

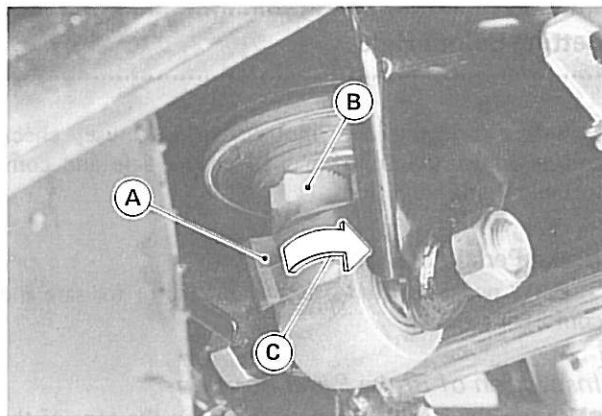

A. Dust Cover C. Larger Damping Force
B. Damper Adjuster

“NOTE”

○The damping force can be left soft for average riding. But it should be adjusted harder for high speed riding, or riding with a passenger. If the damper setting feels too soft or too stiff, adjust it in accordance with the following table:

Damping Force

Position	1	2	3	4
Damping Force	Low ←————→ High			

“NOTE”

○The recommended setting position is 1 for one rider with no accessories.

Headlight:

The headlight beam is adjustable both horizontally and vertically. Headlight aiming must be correctly adjusted for your safe riding as well as oncoming drivers. In most areas it is illegal to ride with improperly adjusted headlights.

Horizontal Adjustment

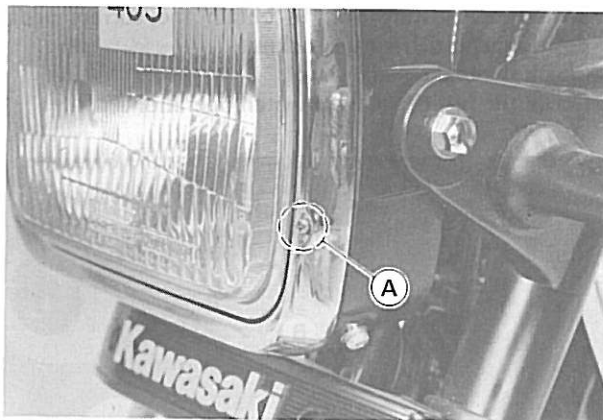

A. Adjusting screw for horizontal adjustment

Vertical Adjustment

- Loosen the lower headlight bolts.
- Loosen the headlight housing mounting nuts, and adjust the headlight vertically.

"NOTE"

○On high beam, the brightest point should be slightly below horizontal with the motorcycle on its wheels and the rider seated. Adjust the headlight to the proper angle according to local regulations.

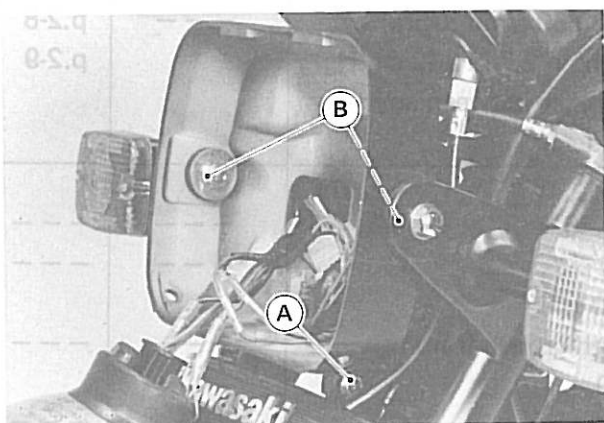
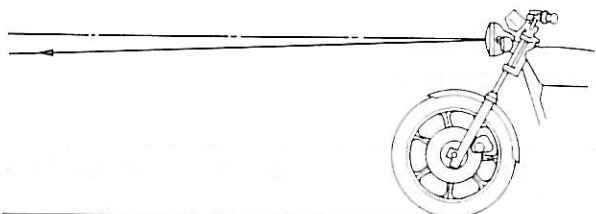
Vertical Adjustment

- A. Headlight stay bolt
- B. Headlight mounting nuts

.....
Service Data

The following tables list the service data which show criteria for servicing major parts. Although reliable measurements can only be obtained by using the proper instruments and following the procedures explained in this text, detail has not been explained in this section. See each section for a detailed account.

"NOTE"

○Refer to p. xxx (shown in the "See Page" column) of the Base Manual.

○Refer to p. x-xx (shown in the "See Page" column) of this Supplement.

Engine:

Item	Model	Standard	Service Limit	See Page
Throttle grip play	All	2 – 3 mm	---	p.2-8
Idle speed	ZR400	1,200 ±50 r/min (rpm)	---	p.2-8
	ZR500/550	1,050 ±50 r/min (rpm)	---	p.2-8
Engine vacuum synchronization	All	Less than 2.7 kPa (2 cm Hg) difference between any two cylinder.		p.2-9
Carburetor:	ZR400			
Make & type		TK K26 V	---	---
Main jet		#102	---	---
Jet needle		#4A01		
Jet needle clip position		Fourth groove from top.	---	---
Air jet		#100		
Pilot jet		#32	---	---
Pilot screw		2 turns out	---	---
Service fuel level		7 ±1 mm	---	---
Float height		27 mm	---	---
	ZR500/550			
Make & type		TK K26 V	---	---
Main Jet		#100	---	---
Jet needle		#4A00	---	---
Jet needle clip position		Second groove from top	---	---
Air jet		#60	---	---
Pilot jet		#32	---	---
Pilot screw		2½ turns out, (W) 2 turns out	---	---
Service fuel level		7 ±1 mm	---	p.381
Float height		27 mm	---	p.381
Camshaft:				
Cam height	ZR400	36.246 – 36.354 mm	36.15 mm	p.3-2
	ZR500/550	35.546 – 35.654 mm	35.45 mm	
Camshaft bearing oil clearance	All	0.088 – 0.131 mm	0.22 mm	p.163
Camshaft journal diameter	All	21.890 – 21.912 mm	21.86 mm	p.163
Camshaft bearing inside diameter	All	22.000 – 22.021 mm	22.08 mm	p.163

(W) : West German Model

Engine (Cont.):

Item	Model	Standard	Service Limit	See Page
Camshaft runout	All	Less than 0.02 mm TIR	0.1 mm TIR	p.163
Camshaft chain 20-link length	All	127.00 – 127.36 mm	128.9 mm	p.164
Cylinder Head, Valves:				
Valve clearance	Inlet	All	0.10 – 0.20 mm	— — — p.2-3
	Exhaust	All	0.15 – 0.25 mm	
Cylinder head warp	All	— — —	0.05 mm	p.165
Combustion chamber volume	All	15.2 – 16.0 mL	— — —	p.165
Valve head thickness:				
	Inlet	All	0.85 – 1.15 mm	0.5 mm p.166
	Exhaust	All	0.85 – 1.15 mm	0.7 mm p.166
Valve stem bend	All	Less than 0.02 mm TIR	0.05 mm TIR	p.167
Valve stem diameter:				
	Inlet	All	5.475 – 5.490 mm	5.46 mm p.167
	Exhaust	All	5.455 – 5.470 mm	5.44 mm p.167
Valve guide inside diameter:				
Inlet & Exhaust	All	5.500 – 5.512 mm	5.58 mm	p.167
Valve installed height				
	Inlet	All	36.09 – 37.01 mm	See p. 3-2 P.170
	Exhaust	All	36.04 – 36.96 mm	
Valve /valve guide clearance (wobble method):				
	Inlet	All	0.02 – 0.09 mm	0.22 mm p.167
	Exhaust	All	0.07 – 0.14 mm	0.27 mm p.167
Valve seating area				
outside diameter:	Inlet	All	27 mm	— — — p.327
	Exhaust	All	23 mm	— — — p.327
width (inlet & exhaust)	All	0.5 – 1.0 mm	— — —	p.168
Valve spring free length:				
	Inner	All	36.7 mm	— — —
	Outer	All	38.7 mm	— — —
Cylinder Block, Pistons:				
Cylinder compression	ZR400	755 – 1,180 kPa (7.7 – 12.0 kg/cm ² , 109 – 171 psi)	— — —	p.171
	ZR500/550	885 – 1,360 kPa (9.0 – 13.9 kg/cm ² , 128 – 198 psi)	— — —	
Cylinder inside diameter	ZR400	52.000 – 52.012 mm	52.10 mm	p.172
	500	55.000 – 55.012 mm	55.10 mm	
	550	58.000 – 58.012 mm	58.10 mm	
Piston diameter	ZR400	51.965 – 51.980 mm	51.83 mm	p.172
	500	54.965 – 54.980 mm	54.83 mm	
	550	57.965 – 57.980 mm	57.83 mm	
Piston-to-cylinder clearance	All	0.020 – 0.047 mm	— — —	p.173

(Continued on next page.)

Engine (Cont.):

Item	Model	Standard	Service Limit	See Page			
Piston ring/groove clearance:	Top	ZR400	0.02 – 0.06 mm	0.16 mm	p.173		
		500	0.04 – 0.08 mm	0.18 mm			
		550	0.02 – 0.06 mm	0.16 mm			
	Second	ZR400	0.02 – 0.06 mm	0.16 mm			
		500	0.04 – 0.08 mm	0.18 mm			
		550	0.04 – 0.075 mm	0.18 mm			
Piston ring thickness:	Top	ZR400/500	1.17 – 1.19 mm	1.10 mm	p.173		
		ZR550	1.175 – 1.19 mm	1.10 mm			
	Second	ZR400/500	1.17 – 1.19 mm	1.10 mm			
		ZR550	1.175 – 1.19 mm	1.10 mm			
Piston ring groove width:	Top	ZR400	1.21 – 1.23 mm	1.31 mm	p.173		
		500	1.23 – 1.25 mm	1.33 mm			
		550	1.21 – 1.23 mm	1.31 mm			
	Second	ZR400	1.21 – 1.23 mm	1.31 mm			
		ZR500/550	1.23 – 1.25 mm	1.33 mm			
		All	2.51 – 2.53 mm	2.61 mm			
	Piston ring end gap:	Top	ZR400/500	0.15 – 0.35 mm		0.7 mm	p.174
			ZR550	0.15 – 0.30 mm		0.6 mm	
		Second	ZR400/500	0.15 – 0.35 mm		0.7 mm	
ZR550			0.15 – 0.30 mm	0.6 mm			
Crankshaft, Connecting Rods:							
Connecting rod bend	All	Less than 0.10/100 mm	0.2/100 mm	p.175			
Connecting rod twist	All	Less than 0.15/100 mm	0.2/100 mm	p.175			
Connecting rod bearing insert/ crankpin clearance	All	0.031 – 0.059 mm	0.10 mm	p.175			
Crankpin diameter: No mark	All	32.984 – 32.994 mm	35.97 mm				
	○ All	32.994 – 33.000 mm	35.97 mm				
Connecting rod big end inside diameter: No mark	All	36.000 – 36.008 mm	---	p.176			
	○ All	36.009 – 36.016 mm	---				
Connecting rod big end bearing insert thickness:	Brown All	1.480 – 1.485 mm	---	p.176			
	Black All	1.485 – 1.490 mm	---				
	Blue All	1.489 – 1.494 mm	---				
Connecting rod big end side clearance	All	0.13 – 0.33 mm	0.50 mm	p.176			
Crankshaft runout	All	Less than 0.02 mm TIR	0.05 mm TIR	P.176			
Crankshaft main bearing insert/ journal clearance	All	0.014 – 0.038 mm	0.08 mm	p.177			

Engine (Cont.):

Item	Model	Standard	Service Limit	See Page
Crankshaft main journal diameter: No mark	All	31.984 – 31.992 mm	31.96 mm	p.177
	1	31.993 – 32.000 mm	31.96 mm	
Crankshaft main bearing bore inside diameter: ○	All	36.000 – 36.008 mm	---	p.178
	No mark	36.009 – 36.016 mm	---	
Crankshaft bearing insert thickness:	Brown	1.991 – 1.995 mm	---	p.178
	Black	1.995 – 1.999 mm	---	
	Blue	1.999 – 2.003 mm	---	
Crankshaft side play	All	0.05 – 0.20 mm	0.40 mm	p.178
Clutch:				
Clutch lever play	All	2 – 3 mm	---	p.2-12
Clutch spring free length	All	32.6 mm	31.7 mm	---
Friction plate thickness	All	2.9 – 3.1 mm	2.7 mm	p.181
Friction and steel plate warp	All	Less than 0.2 mm	0.3 mm	p.181
Transmission:				
Shift fork ear thickness	All	4.9 – 5.0 mm	4.8 mm	p.186
Gear shift fork groove width	All	5.05 – 5.15 mm	5.3 mm	p.186
Shift fork guide pin diameter:				
	Fork on shift rod	All	7.9 – 8.0 mm	7.8 mm
Fork on shift drum	All	7.985 – 8.000 mm	7.9 mm	
Shift drum groove width	All	8.05 – 8.20 mm	8.3 mm	p.187
Engine Lubrication System:				
Relief valve opening pressure	All	430 – 590 kPa (4.4 – 6.0 kg/cm ² , 63 – 85 psi)	---	p.188
Oil pressure @4,000 rpm (r/min), oil temp. 90°C (194°F)	All	196 – 245 kPa (2.0 – 2.5 kg/cm ² , 28 – 36 psi)	---	p.188
Engine oil:				
Grade	All	SE class	---	p.2-11
Viscosity	All	SAE10W40, 10W50, 20W40 or 20W50	---	
Amount	All	3.0 L	---	

(Continued on next page.)

Chassis:

Item	Model	Standard	Service Limit	See Page
Wheels:				
Wheel balance	All	Imbalance of less than 0.1 N (10g)	---	p.31
Tire pay load	All	1,618 N (165 kg, 364 lb)	---	p.1-9
Front tires:				
Make & type	ZR400 ZR500/550	Dunlop F14 Dunlop F8 MkII or Bridgestone L303A	---	---
Tire Size	ZR400 ZR500/550	90/90-19 52S 3.25H19-4 PR	---	---
Air pressure	All	196 kPa (2.0 kg/cm ² , 28 psi)	---	p.2-21
Tread depth	ZR400 ZR500/550	3.4 mm 3.5 mm	1 mm	p.2-21
Rear tires:				
Make & type	ZR400 ZR500/550	Dunlop K130 Dunlop K427 or Bridgestone S716A	---	---
Tire size	ZR400 ZR500/550	110/90-18 61S 4.00H18-4 PR	---	---
Air pressure	All	221 kPa (2.25 kg/cm ² , 32 psi)	---	p.2-21
Tread depth	ZR400 ZR500/550	6.9 mm 7.3 mm	2 mm	p.2-21
Rim runout:				
Axial	All	---	0.5 mm TIR	p.194
Radial	All	---	0.8 mm TIR	
Brakes:				
Brake fluid grade	All	D.O.T.3		p.2-16
Disc runout	All	Less than 0.15 mm TIR	0.3 mm TIR	p.203
Disc thickness	All	3.8 – 4.1 mm	3.5 mm	p.4-2
Brake lining thickness:				
Disc	All	4.5 mm	1 mm	p.2-15
Drum	All	3.5 – 3.7 mm	1.8 mm	p.4-2
Brake drum inside diameter	All	160.00 – 160.16 mm	160.75 mm	p.4-2
Brake pedal position	All	0 – 30 mm	---	p.1-9
Brake light switch:				
Front	All	Non-adjustable	---	---
Rear	All	On after about 15 mm pedal travel	---	---
Front Fork:				
Air pressure	All	59 – 78 kPa (0.6 – 0.8 kg/cm ² 8.5 – 11 psi)	---	p.1-9
Oil amount	All	233.5 – 238.5 mL	---	p.2-20
Oil level (extended, without main spring)	All	495 mm	---	p.2-21
Oil viscosity	All	SAE 5W20	---	p.2-20
Electrical:				
Charging System:				
Regulator/rectifier output voltage	All	Battery voltage – 15 V	---	p.335
Alternator output voltage	All	about 50 V @4,000 r/min (rpm), no loads	---	p.335
Stator coil resistance	All	0.36 – 0.54 Ω	---	p.335

.....
Torque and Locking Agent

The following tables list the tightening torque for the major fasteners requiring use of a non-permanent locking agent or liquid gasket.

Letters used in the "Remarks" column mean:

A : Apply a non-permanent locking agent to the threads.

G : Apply a liquid gasket to the threads or washers.

S : Tighten the fasteners following the specified sequence.

St : Stake the fasteners to prevent loosening.

Engine Part	Dia. x Pitch (mm)	Quantity	Torque			Remark	See * Page
			N-m	kg-m	ft-lb		
Engine Top End							
Air cleaner housing mounting screws	6 x 1.0	4	4.9	0.50	43 in-lb	—	361
Breather cover bolt	8 x 1.25	1	5.9	0.60	52 in-lb	—	69
Camshaft cap bolts	6 x 1.0	16	12	1.2	104 in-lb	S	59
Camshaft chain tensioner cap	18 x 1.5	1	25	2.5	18.0	—	60
Camshaft sprocket bolts	6 x 1.0	4	15	1.5	11.0	A	61
Carburetor holder Allen bolts	6 x 1.0	8	15	1.5	11.0	A	362
Carburetor holder screws	6 x 1.0	8	—	—	—	A	272
Cylinder nuts	6 x 1.0	3	12	1.2	104 in-lb	S	66
Cylinder head:							
bolts	6 x 1.0	5	12	1.2	104 in-lb	S	62
nuts	8 x 1.25	12	23	2.3	16.5	S	62
Cylinder head cover bolts	6 x 1.0	24	9.8	1.0	87 in-lb	—	60
Spark plugs	12 x 1.25	4	14	1.4	10.0	—	12
Engine Left Side							
Alternator rotor bolt	10 x 1.25	1	69	7.0	51	—	76
Alternator stator Allen bolts	6 x 1.0	3	9.8	1.0	87 in-lb	A	76
Engine sprocket holding plate bolts	6 x 1.0	2	9.8	1.0	87 in-lb	A	71
Neutral switch	20 x 1.5	1	15	1.5	11.0	—	73
Return spring pin	8 x 1.5	1	20	2.0	14.5	A	72
Shift drum pin plate screw	6 x 1.0	1	—	—	—	A	106
Shift pedal pivot bolt	14 x 1.5	1	25	2.5	18.0	A	322
Stator motor terminal nut	6 x 1.0	1	11	1.1	95 in-lb	—	273

* : Refer to indicated pages of the Base Manual.

(Continued on next page.)

Torque and Locking Agent (Cont.):

Engine Part	Dia. x Pitch (mm)	Quantity	Torque			Remark	See * Page
			N-m	kg-m	ft-lb		
Engine Right Side							
Clutch hub nut	20 x 1.5	1	130	13.5	98	—	80
Clutch spring bolts	6 x 1.0	5	8.8	0.90	78 in-lb	—	80
Timing advancer mounting bolt	8 x 1.25	1	25	2.5	18.0	—	78
Engine Bottom End							
Engine drain plug	12 x 1.5	1	29	3.0	22	—	24
Oil filter mounting bolt	20 x 1.5	1	20	2.0	14.5	—	24
Oil pan bolts	6 x 1.0	13	9.8	1.0	87 in-lb	—	82
Oil pressure relief valve	12 x 1.25	1	15	1.5	11.0	A	82
Oil pump screws	6 x 1.0	2	—	—	—	St	83
Secondary shaft nut	18 x 1.5	1	59	6.0	43	—	86
Starter motor clutch Allen bolts	8 x 1.25	3	34	3.5	25	A	87
Engine Removal							
Engine mounting bolts	10 x 1.25	4	34	3.5	25	—	366
Engine mounting bracket bolts	8 x 1.25	6	24	2.4	17.5	—	95,366
Engine Split							
Connecting rod big end cap nuts	7 x 0.75	8	24	2.4	17.5	—	111
Crankcase bolts:							
upper	6 x 1.0	13	9.8	1.0	87 in-lb	—	102
lower	6 x 1.0	7	9.8	1.0	87 in-lb	—	100
lower	8 x 1.25	10	25	2.5	18.0	S	100
Crankcase main passage nozzle	6 x 1.0	1	—	—	—	St	—

Chassis Part	Dia. x Pitch (mm)	Quantity	Torque			Remark	See * Page
			N-m	kg-m	ft-lb		
Wheels							
Front axle clamp bolt	8 x 1.25	1	14	1.4	10.0	—	115
Front axle nut	14 x 1.5	1	64	6.5	47	—	115
Rear axle nut	16 x 1.5	1	78	8.0	58	—	29
Rear sprocket nuts	10 x 1.25	6	34	3.5	25	—	126
Speedometer pinion pin	—	1	—	—	—	St	117
Tire air valve nuts	8 x 0.8	2	1.5	0.15	13 in-lb	—	282

* : Refer to indicated pages of the Base Manual.

Torque and Locking Agent (Cont.):

Chassis Part	Dia. x Pitch (mm)	Quantity	Torque			Remark	See Page *
			N-m	kg-m	ft-lb		
Brakes							
Bleed valve	7 x 1.0	1/caliper	7.8	0.80	69 in-lb	—	118
Brake hose banjo bolts	10 x 1.25	2/hose	25	2.5	18.0	—	119
Brake lever pivot bolt locknut	6 x 1.0	1	5.9	0.60	52 in-lb	—	123
Disc mounting Allen bolts	8 x 1.25	5/disc	23	2.3	16.5	—	117
Front brake light switch mounting screw	4 x 0.7	1	—	—	—	A	366
Caliper mounting bolts	8 x 1.25	2/caliper	29	3.0	22	—	115
Master cylinder clamp bolts	6 x 1.0	2	8.8	0.90	78 in-lb	S	121
Torque link nuts	10 x 1.25	2	29	3.0	22	—	29
Steering							
Handlebar clamp bolts	8 x 1.25	2	34	3.5	25	—	368
Handlebar holder bolts	32 x 1.5	2	98	10.0	72	—	368
Steering stem head bolt	14 x 1.5	1	42	4.3	31	—	356
Suspensions							
Front fork bottom Allen bolts	8 x 1.25	2	18	1.8	13.0	A, G	148
Front fork clamp bolts:							
upper	8 x 1.25	2	18	1.8	13.0	—	148
lower	8 x 1.25	4	18	1.8	13.0	—	31
Front fork drain bolts	6 x 1.0	2	7.8	0.80	69 in-lb	G	150
Rear shock absorber bolts	12 x 1.25	2	69	7.0	51	—	372
Rocker arm pivot shaft — UNI-TRAK	14 x 1.5	1	88	9.0	65	—	372
Swing arm pivot shafts	16 x 1.5	2	78	8.0	58	—	372
Tie-rod bolts—UNI-TRAK	10 x 1.25	2	37	3.8	27	—	372
Electrical Equipment							
IC igniter mounting bolts (with insulation bushings)	6 x 1.0	2	6.4	0.65	56 in-lb	—	—
Turn signal mounting nuts	10 x 1.25	4	13	1.3	113 in-lb	—	326

* : Refer to indicated pages of the Base Manual.

(Continued on next page.)

The table below, relating tightening torque to thread diameter, list the basic torque for the bolts and nuts used on Kawasaki Motorcycles. However, the actual torque that is necessary may vary among bolts and nuts with the same thread diameter. Tightening torque listed in the preceding tables varies to a greater or lesser extent from what is given in the table below. Refer to this table for only the bolts and nuts not included in the tables on the previous pages. All of the values are for use with dry solvent-cleaned threads.

General Fasteners:

Threads dia. (mm)	Torque		
	N-m	kg-m	ft-lb
5	3.4 – 4.9	0.35 – 0.50	30 – 43 in-lb
6	5.9 – 7.8	0.60 – 0.80	52 – 69 in-lb
8	14 – 19	1.4 – 1.9	10.0 – 13.5
10	25 – 34	2.6 – 3.5	19.0 – 25
12	44 – 61	4.5 – 6.2	33 – 45
14	73 – 98	7.4 – 10.0	54 – 72
16	115 – 155	11.5 – 16.0	83 – 115
18	165 – 225	17.0 – 23	125 – 165
20	225 – 325	23 – 33	165 – 240

.....
Special Tools

The following table and figures list the Kawasaki Special Tools and Equipment, which are used during servicing Kawasaki motorcycles.

In order to perform the work efficiently and to avoid costly mistakes, it is important to use the tools and equipment in a correct manner. When special cares are required to operate any tools or equipment; operating instructions are attached to them, or given in this manual. Heed their instructions.

Due to improvements in design and performance during production, in some cases there may be minor discrepancies between the actual tools and the photographs.

Ref. No.	Part Number	Tool Name	Remarks
1	57001-115	Piston ring pliers	p.67
2	57001-135	Bearing puller—This tool contains 2-1.	p.85,101,147
	(or P/N 57001-158)		
2-1	57001-136		
3	57001-137	Stem bearing driver	p.370
4	57001-143	Inside circlip pliers	—
5	57001-144	Outside circlip pliers	—
6	57001-149	Piston base, ϕ 2.3	p.65
7	57001-164	Oil pressure gauge assembly	p.188
8	57001-183	Front fork cylinder holder handle	p.148
9	57001-221	Compression gauge	p.172
10	57001-241	Valve spring compressor assembly— This assembly contains 10-1.	p.62
10-1	57001-242	Adapter, ϕ 30 (no used)	
11	57001-264	Oil seal guide, ϕ 13	p.72
12	57001-297	Bearing driver	—
13	57001-305	Clutch holder	p.79,98
14	57001-308	Flywheel holder	p.76,84,97
15	57001-317	Bearing puller adapter	p.85,101,108
16	57001-319	Gear pusher & puller	p.86
17	57001-351	Throttle valve adjuster	p.2-9,353
18	57001-382	Bearing driver	p.87,108
19	57001-403	Oil pressure gauge adapter	p.188
20	57001-900	Engine stand	p.96
21	57001-910	Piston pin puller assembly—This assembly contains 21-1 through 21-3.	p.67
21-1	57001-912	Adapter "A"	p.67
21-2	57001-913	Adapter "B" (no used)	
21-3	57001-914	Adapter "C" (no used)	
22	57001-980	Electrotester	—

(Continued on next page.)

Ref. No.	Part Number	Tool Name	Remarks
23	57001-983	Hand tester	—
24	57001-1011	Front fork cylinder holder adapter	p.148
25	57001-1017	Fuel level gauge	p.381
26	57001-1018	Compression gauge adapter hose	p.172
27	57001-1021	Valve guide arbor, ϕ 5.35	p.63
28	57001-1024	Spark plug wrench	—
29	57001-1063	Rim protector	p.282
30	57001-1072	Bead breaker assembly—This assembly	
		contains 30-1.	p.281,289
30-1	57001-1073	Tire iron (lever)	p.282
31	57001-1074	Stem bearing driver adapter	p.370
32	57001-1075	Stem bearing driver press shaft assembly	p.369
33	57001-1076	Stem bearing driver	p.369
34	57001-1078	Valve spring compressor adapter, ϕ 29.5	p.62
35	57001-1079	Valve guide reamer, ϕ 5.5	p.63
36	57001-1091	Front fork oil seal driver	p.283,285
37	57001-1094	Piston ring compressor assembly—This	
		assembly contains 37-1 through 37.3.	p.66
37-1	57001-1095	Grip assembly	p.66
37-2	57001-1096	Belt, ϕ 50 — ϕ 67	p.66
37-3	57001-1097	Belt, ϕ 67 — ϕ 79 (no used)	
38	57001-1099	Rotor puller, M16P 1.5 x M18P 1.5	p.76, 97
39	57001-1100	Stem nut wrench	p.2-19,356
40	57001-1106	Stem bearing driver	p.369
41	57001-1107	Stem bearing remover	p.369
42	57001-1110	Valve seat cutter set—This set contains	p.328
		42-1 through 42-16.	
42-1	57001-1111	Case	
42-2	57001-1112	Separate case	
42-3	57001-1114	45° cutter, ϕ 27.5	p.328
42-4	57001-1115	45° cutter, ϕ 32.0	p.328
42-5	57001-1116	45° cutter, ϕ 35.0 (no used)	
42-6	57001-1117	45° cutter, ϕ 41.5 (no used)	
42-7	57001-1119	32° cutter, ϕ 28.0	p.328
42-8	57001-1120	32° cutter, ϕ 30.0	p.328
42-9	57001-1121	32° cutter, ϕ 35.0 (no used)	
42-10	57001-1122	32° cutter, ϕ 38.5 (no used)	
42-11	57001-1123	60° cutter, ϕ 30.0	p.328
42-12	57001-1124	60° cutter, ϕ 41.0 (no used)	
42-13	57001-1125	Holder, ϕ 5.5	p.327
42-14	57001-1126	Holder, ϕ 7.0 (no used)	

Ref. No.	Part Number	Tool Name	Remarks
42-15	57001-1127	Holder, ϕ 8.0 (no used)	
42-16	57001-1128	Handlebar	p.327
43	57001-1129	Bearing driver set—This set contains 43-1 through 43-20.	—
43-1	57001-1130	Case	
43-2	57001-1131	Separate case	
43-3	57001-1132	Holder	
43-4	57001-1133	Inner driver, ϕ 10	
43-5	57001-1134	Inner driver, ϕ 12	
43-6	57001-1135	Inner driver, ϕ 15	
43-7	57001-1136	Inner driver, ϕ 17	
43-8	57001-1137	Inner driver, ϕ 20	
43-9	57001-1138	Inner driver, ϕ 22	
43-10	57001-1139	Inner driver, ϕ 25	
43-11	57001-1140	Inner driver, ϕ 30	
43-12	57001-1141	Inner driver, ϕ 35	
43-13	57001-1142	Outer driver, ϕ 28 x ϕ 30	
43-14	57001-1143	Outer driver, ϕ 32 x ϕ 35	
43-15	57001-1144	Outer driver, ϕ 37 x ϕ 40	
43-16	57001-1145	Outer driver, ϕ 42 x ϕ 47	
43-17	57001-1146	Outer driver, ϕ 46 x ϕ 51	
43-18	57001-1147	Outer driver, ϕ 52 x ϕ 55	
43-19	57001-1148	Outer driver, ϕ 62 x ϕ 68	
43-20	57001-1149	Outer driver, ϕ 72 x ϕ 75	
44	57001-1152	Vacuum gauge set	p.2-9,353
45	52005-1003	Air pressure gauge	p.1-10

(Continued on next page.)

"NOTE"

- Refer to p. xxx (shown in the "Remarks" column) of the Base Manual.
- Refer to p. x-xx (shown in the "Remarks" column) of this Supplement.

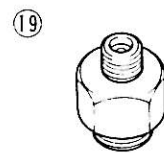
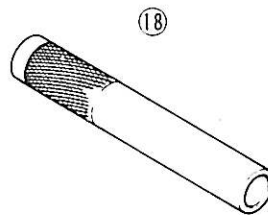
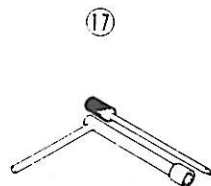
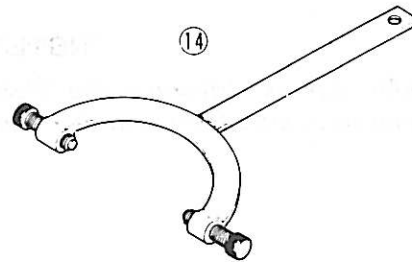
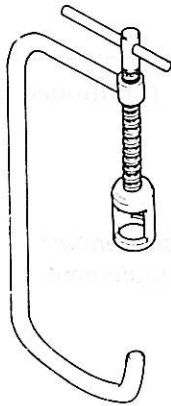
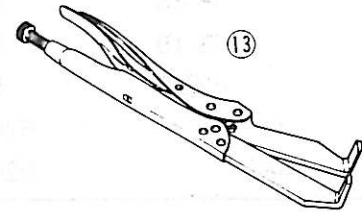
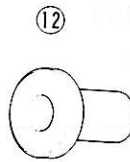
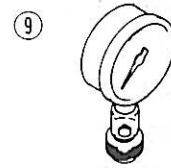
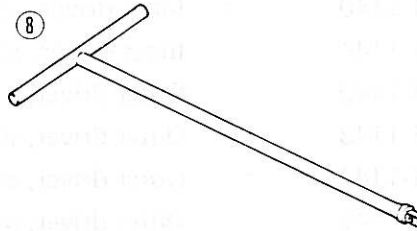
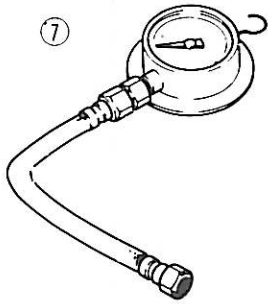
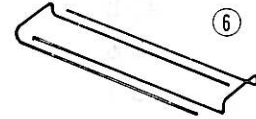
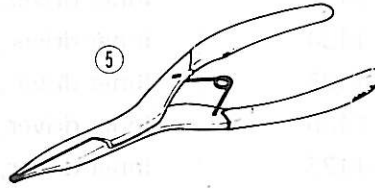
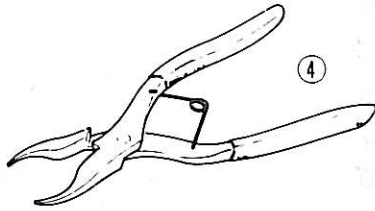
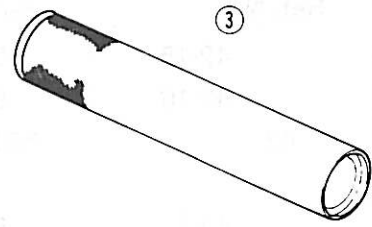
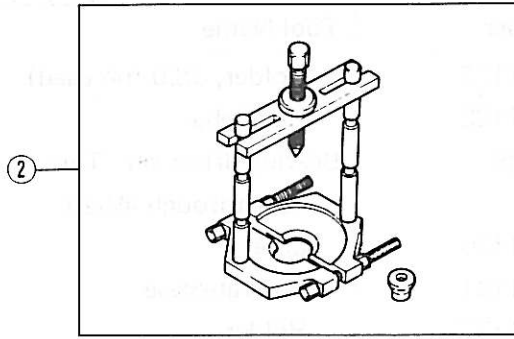
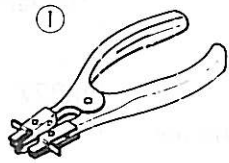

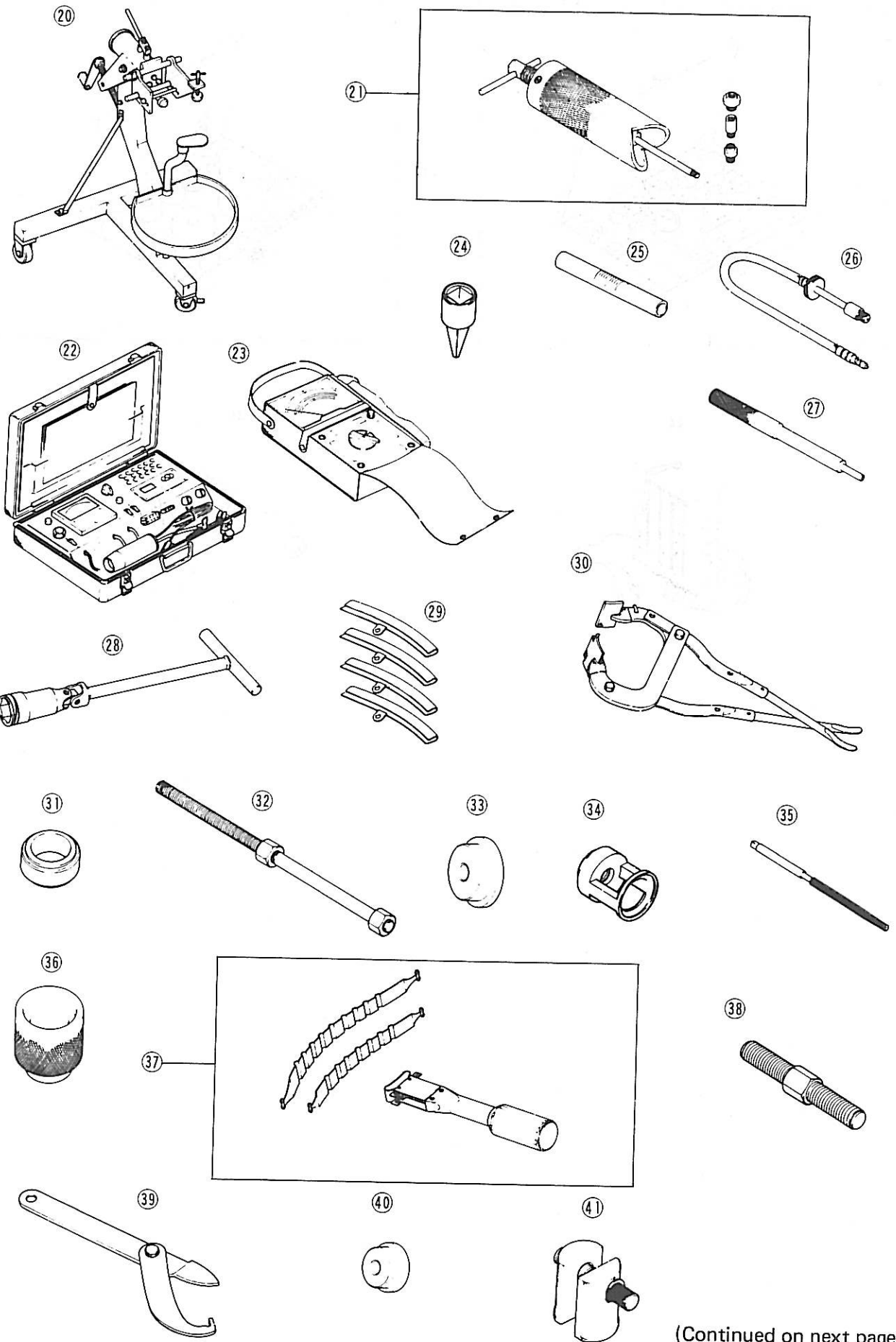

(Continued on next page.)

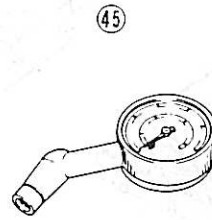
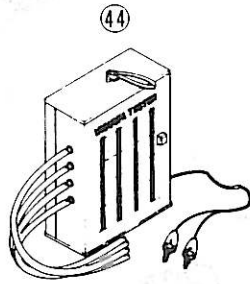
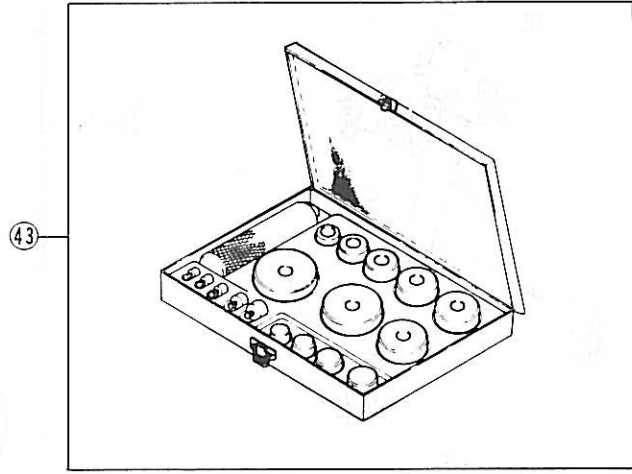
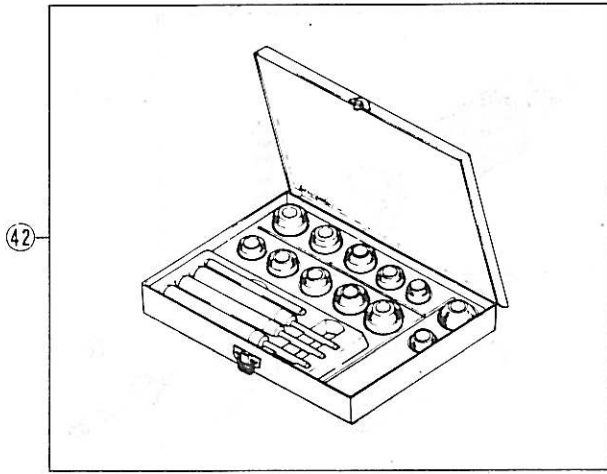

ZR400-A1, ZR500-A1, ZR550-A1, Wiring Diagram

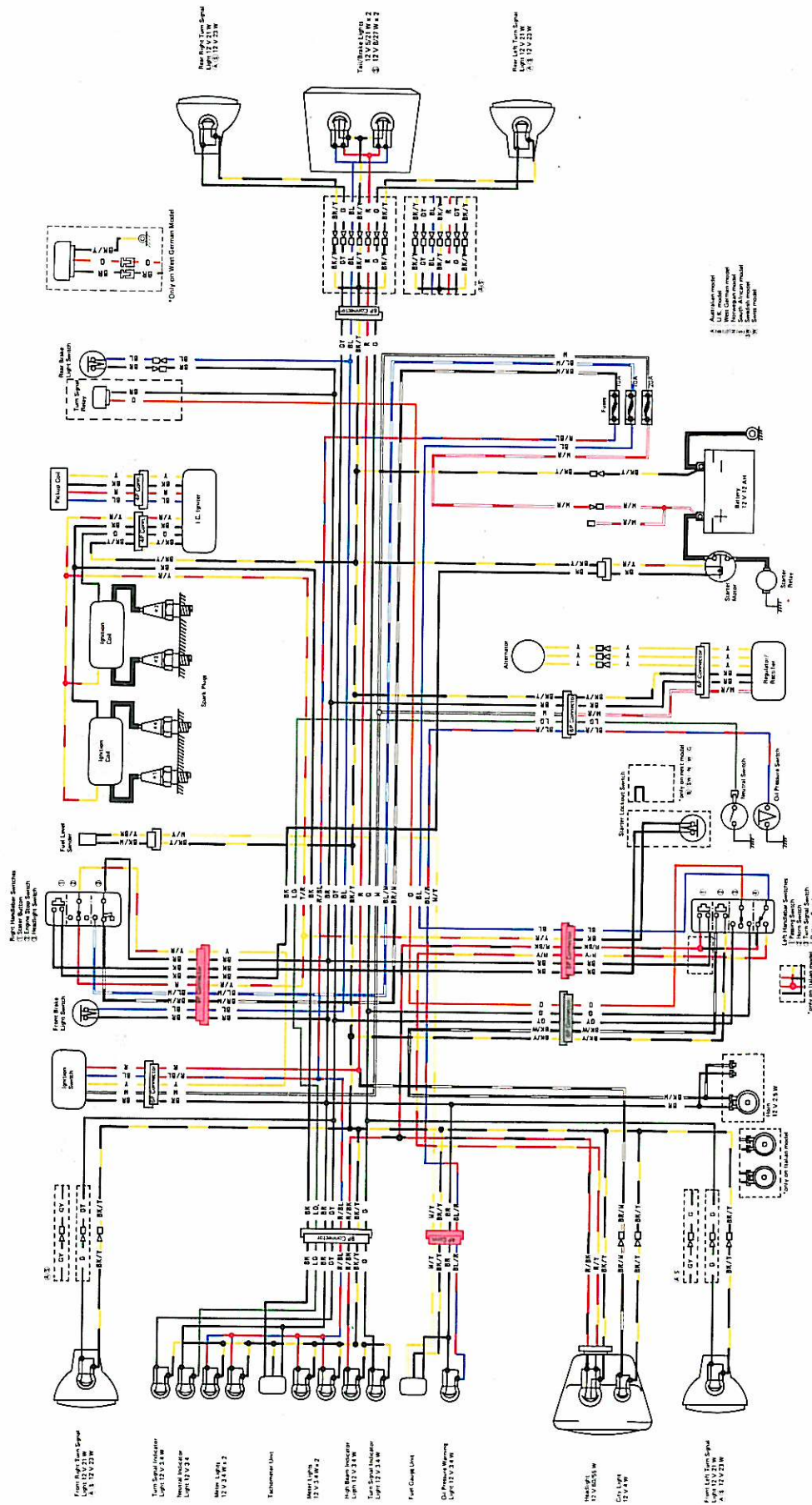

12	12
11	11
10	10
9	9
8	8
7	7
6	6
5	5
4	4
3	3
2	2
1	1

RIGHT HANDLEBAR SWITCH CONNECTIONS									
Color	Code	Switch	Y/N	Red	Green	Blue	Black	White	12.5W
Green	12	Turn Signal							
Blue	11	Turn Signal							
Black	10	Turn Signal							
White	9	Turn Signal							
Red	8	Turn Signal							
Yellow	7	Turn Signal							
Orange	6	Turn Signal							
Purple	5	Turn Signal							
Grey	4	Turn Signal							
Brown	3	Turn Signal							
Pink	2	Turn Signal							
Light Blue	1	Turn Signal							

CENTER SWITCH CONNECTIONS									
Color	Code	Switch	Y/N	Red	Green	Blue	Black	White	12.5W
Green	12	Turn Signal							
Blue	11	Turn Signal							
Black	10	Turn Signal							
White	9	Turn Signal							
Red	8	Turn Signal							
Yellow	7	Turn Signal							
Orange	6	Turn Signal							
Purple	5	Turn Signal							
Grey	4	Turn Signal							
Brown	3	Turn Signal							
Pink	2	Turn Signal							
Light Blue	1	Turn Signal							

LEFT HANDLEBAR SWITCH CONNECTIONS									
Color	Code	Switch	Y/N	Red	Green	Blue	Black	White	12.5W
Green	12	Turn Signal							
Blue	11	Turn Signal							
Black	10	Turn Signal							
White	9	Turn Signal							
Red	8	Turn Signal							
Yellow	7	Turn Signal							
Orange	6	Turn Signal							
Purple	5	Turn Signal							
Grey	4	Turn Signal							
Brown	3	Turn Signal							
Pink	2	Turn Signal							
Light Blue	1	Turn Signal							

1976A, 1976A, 1976AB

Scheduled Maintenance

Table of Contents

2

Periodic Maintenance Chart	2-2
DISCRIPTION OF EACH OPERATION	
Spark Plugs	2-3
Timing Advancer	2-3
Valve Clearance	2-3
Air Clearaner Element	2-7
Throttle Grip	2-8
Idle Speed	2-8
Engine Vacuum Synchronization	2-9
Fuel System	2-10
Engine Oil	2-10
Clutch	2-12
Drive Chain	2-12
Brakes	2-15
Steering	2-19
Fork Oil	2-20
Wheels	2-21
Swing Arm, Uni-Trak	2-22
Battery	2-23
General Lubrication	2-23
Bolts, Nuts, Fasteners	2-24
Brake Light Switch	2-24

.....
Periodic Maintenance Chart

The scheduled maintenance must be done in accordance with this chart to keep the motorcycle in good running condition. The initial maintenance is vitally important and must not be neglected.

OPERATION	FREQUENCY	* ODOMETER READING							See Page
		Whichever comes first ↓ Every	800 km	5,000 km	10,000 km	15,000 km	20,000 km	25,000 km	
Spark plug – clean		•	•	•	•	•	•	•	p.2-3
Spark plug – check †		•	•	•	•	•	•	•	p.2-3
Timing advancer – lubricate				•				•	p.2-3
Valve clearance – check †		•	•	•	•	•	•	•	p.2-4
Air cleaner element – clean			•	•			•		p.2-7
Air cleaner element – replace	5 cleanings			•		•		•	–
Throttle grip play – check †		•	•	•	•	•	•	•	p.2-8
Idle speed – check †		•	•	•	•	•	•	•	p.2-8
Engine vacuum synchronization – check †		•	•	•	•	•	•	•	p.2-9
Fuel system – check †				•		•		•	p.2-10
Cylinder head bolt tightness – check †		•		•		•		•	p.1-17
Engine oil – change	year	•	•	•	•	•	•	•	p.2-11
Oil filter – replace		•		•		•		•	p.6-2
Fuel hose – replace	4 years								–
Clutch – adjust		•	•	•	•	•	•	•	p.2-12
Drive chain wear – check †			•	•	•	•	•	•	p.2-14
Drive chain – lubricate	300 km								p.2-14
Drive chain slack – check †	800 km								p.2-12
Brake lining wear – check †			•	•	•	•	•	•	p.2-15
Brake fluid level – check †	month	•	•	•	•	•	•	•	p.2-16
Brake fluid – change	year			•		•		•	p.2-17
Brake hose – replace	4 years								p.7-1
Master cylinder cup and dust seal – replace	2 years								p.7-1
Caliper piston seal and dust seal – replace	2 years								p.7-1
Brake play – check †		•	•	•	•	•	•	•	p.2-15
Brake light switch – check †		•	•	•	•	•	•	•	p.2-24
Brake camshaft – lubricate	2 years					•			p.2-18
Steering – check †		•	•	•	•	•	•	•	p.2-19
Steering stem bearing – lubricate	2 years					•			p.2-20
Front fork oil – change				•		•		•	p.2-20
Tire wear – check †			•	•	•	•	•	•	p.2-21
Wheel bearing – lubricate	2 years					•			p.2-22
Speedometer gear – lubricate	2 years					•			p.2-22
Swing arm pivot, uni-trak linkage – lubricate				•		•		•	p.2-22
Battery electrolyte level – check †	month	•	•	•	•	•	•	•	p.2-23
General lubrication – perform			•	•	•	•	•	•	p.2-23
Nut, bolt, and fastener tightness – check †		•		•		•		•	p.2-24

* : For higher odometer readings, repeat at the frequency interval established here.

† : Replace, add, adjust, clean, or torque if necessary.

Spark Plugs

Cleaning and Gapping

- Remove the spark plugs.
- Clean the spark plug preferably in a sand-blasting device, and then clean off any abrasive particles. The plug may also be cleaned using a high flash-point solvent and a wire brush or other suitable tool.
- ★ If the spark plug electrodes are corroded or damaged, or if the insulator is cracked, replace the plug. Use the standard plug or its equivalent.
- Measure the gap with a wire-type thickness gauge.
- ★ If the gap is incorrect carefully bend the side electrode, with a suitable tool to obtain the correct gap.
- Tighten the spark plugs in the cylinder head to specified torque.

Standard Spark Plug:

NGK DR8ES or ND X24ESR-U
 (A) (I) (N) (S) NGK D8EA or ND X24ES-U
 Plug Gap: 0.6 – 0.7 mm
 Tightening Torque: 14 N·m (1.4 kg·m, 10.0 ft·lb)

- (A) : Australian model
- (I) : Italian model
- (N) : Norwegian model
- (S) : South African model

Spark Plug

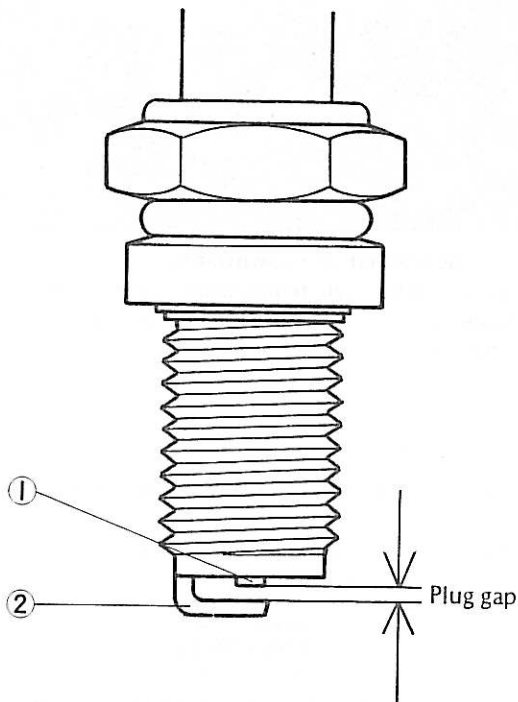

1. Center Electrode 2. Side Electrode

Timing Advancer

Lubrication

- Remove the automatic timing advancer, and disassemble it.
- Wash each part with a high flash-point solvent, and dry tem.
- Apply grease sparingly to the points indicated in the figure.
- Assemble the advancer, and wipe off the excess grease.

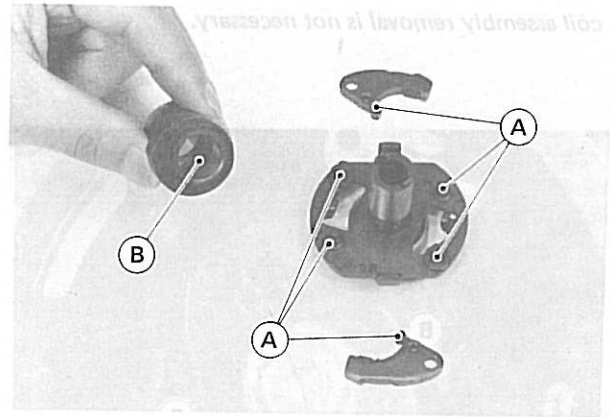

A. Apply Grease. B. Fill the groove with grease.

Valve Clearance

Inspection

- If the engine is hot, wait until the engine cools. Valve clearance must be checked when the engine is cold (room temperature).
- Disconnect the battery negative (-) lead from the battery to prevent the engine from turning accidentally.
- Check the valve clearance when pistons are at TDC.
- Using a 17 mm wrench on the crankshaft rotation nut, turn the crankshaft until a TDC mark on the timing advancer is aligned with the line mark on the crankcase. Measure the valve clearance of the valves of which cam lobe is pointing away from the valve lifter.

TDC of the #1 and #4 pistons →

Inlet #1 and #3 valve clearances

or

Inlet #2 and #4 valve clearance

TDC of the #2 and #3 piston →

Exhaust #1 and #3 valve clearances

or

Exhaust #2 and #4 valve clearances

"NOTE"

○In the figure below, the pickup coil assembly is removed for explanation. In actual procedure pickup coil assembly removal is not necessary.

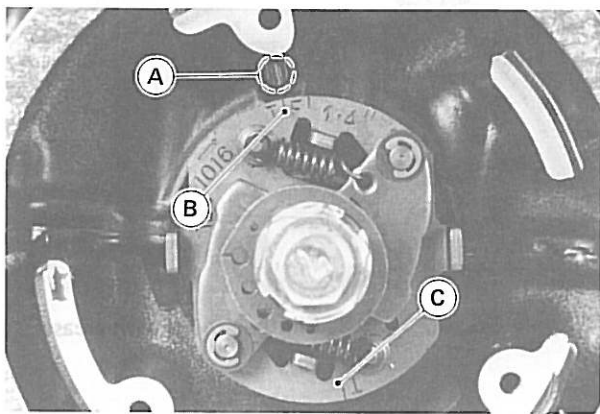

A. Timing Mark
B. 1 · 4 T Mark
C. 2 · 3 T Mark

*If the valve clearance is incorrect, adjust it.

Valve Numbering Method (viewed from top)

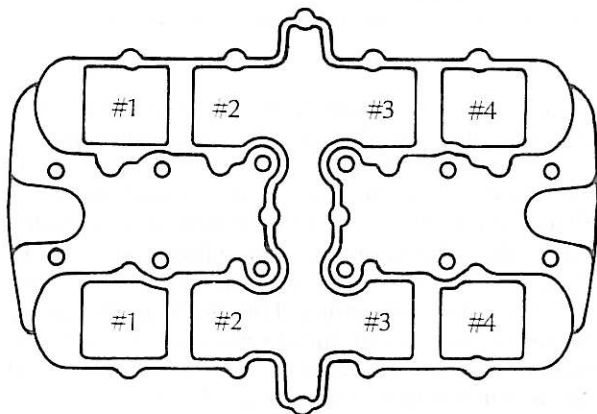

Valve Clearance

Inlet:	0.10 – 0.20 mm
Exhaust:	0.15 – 0.25 mm

Adjustment

●To change the valve clearance, remove the camshafts and the valve lifters, and replace the present shim on the valve spring retainer with a shim of different thickness.

CAUTION

○If the valve timing is upsetted, the engine could be seriously damaged.

●To select a new shim which brings valve clearance within the specified limit, refer to the Valve Clearance Adjustment Chart.

●Shim thickness is printed on the shim surface. When installing, face the marked side toward the spring retainer. This avoids the marking from being polished off by the action of the valve lifter.

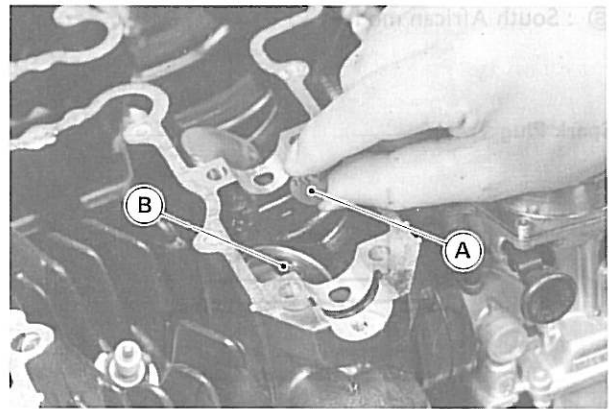

A. Face the marked side downwards.
B. Apply a little high temperature grease to the spring retainer to keep the shim in place during camshaft installation.

●Install the camshafts. Be sure to time the camshafts properly.
●Remeasure the valve clearance that was adjusted. Readjust if necessary.

CAUTION

○Do not put shim stock under the shim. This may cause the shim to pop out at high rpm, causing extensive engine damage.

Inlet Valve Clearance Adjustment Chart

PART NUMBER (92025)	PRESENT SHIM																								
	1090	1091	1092	1093	1094	1095	1096	1097	1098	1099	1100	1101	1102	1103	1104	1105	1106	1107	1108	1109	1110	1111	1112	1113	1114
THICKNESS (mm)	2.00	2.05	2.10	2.15	2.20	2.25	2.30	2.35	2.40	2.45	2.50	2.55	2.60	2.65	2.70	2.75	2.80	2.85	2.90	2.95	3.00	3.05	3.10	3.15	3.20
0.00 ~ 0.02				2.00	2.05	2.10	2.15	2.20	2.25	2.30	2.35	2.40	2.45	2.50	2.55	2.60	2.65	2.70	2.75	2.80	2.85	2.90	2.95	3.00	3.05
0.03 ~ 0.07			2.00	2.05	2.10	2.15	2.20	2.25	2.30	2.35	2.40	2.45	2.50	2.55	2.60	2.65	2.70	2.75	2.80	2.85	2.90	2.95	3.00	3.05	3.10
0.08 ~ 0.09		2.00	2.05	2.10	2.15	2.20	2.25	2.30	2.35	2.40	2.45	2.50	2.55	2.60	2.65	2.70	2.75	2.80	2.85	2.90	2.95	3.00	3.05	3.10	3.15
0.10 ~ 0.20																									
0.21 ~ 0.22																									
0.23 ~ 0.27																									
0.28 ~ 0.32																									
0.33 ~ 0.37																									
0.38 ~ 0.42																									
0.43 ~ 0.47																									
0.48 ~ 0.52																									
0.53 ~ 0.57																									
0.58 ~ 0.62																									
0.63 ~ 0.67																									
0.68 ~ 0.72																									
0.73 ~ 0.77																									
0.78 ~ 0.82																									
0.83 ~ 0.87																									
0.88 ~ 0.92																									
0.93 ~ 0.97																									
0.98 ~ 1.02																									
1.03 ~ 1.07																									
1.08 ~ 1.12																									
1.13 ~ 1.17																									
1.18 ~ 1.22																									
1.23 ~ 1.27																									
1.28 ~ 1.32																									
1.33 ~ 1.37																									

SPECIFIED CLEARANCE / NO CHANGE REQUIRED

INSTALL THE SHIM OF THIS THICKNESS (mm)

1. Align the timing advancing "T" mark with the crankcase timing mark, and measure the clearance (when cold).
2. Check present shim size.
3. Match clearance in vertical column with present shim size in horizontal column.
4. The shim specified where the lines intersect is the one that will give you the proper clearance.

NOTE: If there is no clearance between the shim and the cam, select a shim which is several sizes smaller and then measure the clearance.

- CAUTION**
1. Do not put shim stock under the shim. This may cause the shim to pop out at high rpm causing extensive engine damage.
 2. Do not grind the shim. This may cause it to fracture, causing extensive engine damage.
 3. Check the valve clearance with the proper method in the text. Checking the clearance at any other cam position may result in improper valve clearance.

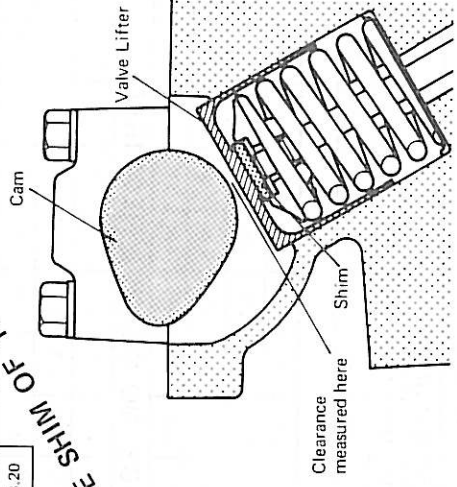

Exhaust Valve Clearance Adjustment Chart

VALVE CLEARANCE (mm)	PRESENT SHIM																								
	1090	1091	1092	1093	1094	1095	1096	1097	1098	1099	1100	1101	1102	1103	1104	1105	1106	1107	1108	1109	1110	1111	1112	1113	1114
0.00 ~ 0.02	2.00	2.05	2.10	2.15	2.20	2.25	2.30	2.35	2.40	2.45	2.50	2.55	2.60	2.65	2.70	2.75	2.80	2.85	2.90	2.95	3.00	3.05	3.10	3.15	3.20
0.03 ~ 0.07				2.00	2.05	2.10	2.15	2.20	2.25	2.30	2.35	2.40	2.45	2.50	2.55	2.60	2.65	2.70	2.75	2.80	2.85	2.90	2.95	3.00	3.05
0.08 ~ 0.12			2.00	2.05	2.10	2.15	2.20	2.25	2.30	2.35	2.40	2.45	2.50	2.55	2.60	2.65	2.70	2.75	2.80	2.85	2.90	2.95	3.00	3.05	3.10
0.13 ~ 0.14		2.00	2.05	2.10	2.15	2.20	2.25	2.30	2.35	2.40	2.45	2.50	2.55	2.60	2.65	2.70	2.75	2.80	2.85	2.90	2.95	3.00	3.05	3.10	3.15
0.15 ~ 0.25																									
0.26 ~ 0.27																									
0.28 ~ 0.32																									
0.33 ~ 0.37																									
0.38 ~ 0.42																									
0.43 ~ 0.47																									
0.48 ~ 0.52																									
0.53 ~ 0.57																									
0.58 ~ 0.62																									
0.63 ~ 0.67																									
0.68 ~ 0.72																									
0.73 ~ 0.77																									
0.78 ~ 0.82																									
0.83 ~ 0.87																									
0.88 ~ 0.92																									
0.93 ~ 0.97																									
0.98 ~ 1.02																									
1.03 ~ 1.07																									
1.08 ~ 1.12																									
1.13 ~ 1.17																									
1.18 ~ 1.22																									
1.23 ~ 1.27																									
1.28 ~ 1.32																									
1.33 ~ 1.37																									
1.38 ~ 1.45																									

SPECIFIED CLEARANCE / NO CHANGE REQUIRED

1. Align the timing advance "T" mark with the crankcase timing mark, and measure the clearance (when cold).
2. Check present shim size.
3. Match clearance in vertical column with present shim size in horizontal column.
4. The shim specified where the lines intersect is the one that will give you the proper clearance.

NOTE: If there is no clearance between the shim and the cam, select a shim which is several sizes smaller and then measure the clearance.

CAUTION

1. Do not put shim stock under the shim. This may cause the shim to pop out at high rpm causing extensive engine damage.
2. Do not grind the shim. This may cause it to fracture, causing extensive engine damage.
3. Check the valve clearance with the proper method in the text. Checking the clearance at any other cam position may result in improper valve clearance.

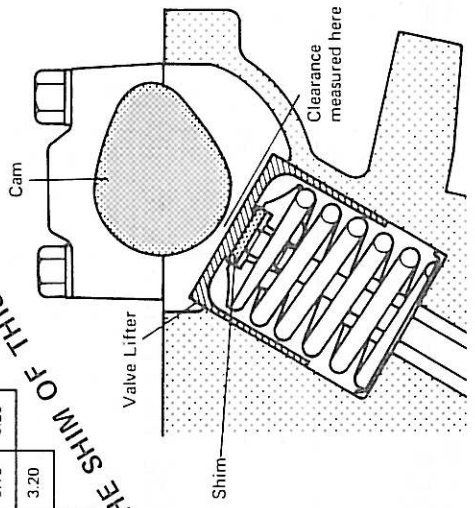

VALVE CLEARANCE (mm)

INSTALL THE SHIM OF THIS THICKNESS (mm)

- Do not grind the shim. This may cause it to fracture, causing extensive engine damage.
- Do not grind the valve stem end or repair it or to permit additional valve clearance. If the valve end is ground, the shim may contact the spring retainer and/or split keepers during operation, allowing the keeper to loosen. Consequently, the valve may drop into the engine, causing serious damage.

- If any part of the element is damaged, the element must be replaced, or it will allow dirt into the carburetors.

— For Left Side Element —

- Clean the element in a bath of a high flash-point solvent, and then dry it with compressed air or by shaking it. Don't oil the element, or carburetion will be upset.

CAUTION

- Since this is a dry-type element, do not use kerosene or any fluid which would leave the element oily.

— For Right Side Element —

- Clean the element in a bath of a high flash-point solvent, and then dry it with compressed air or by shaking it.
- After cleaning, saturate the sponge filter with SE class SAE 30 oil, squeeze out the excess, then wrap it in a clean rag and squeeze it dry as possible. Be careful not to tear the sponge filter.

— For Both Side Elements —

WARNING

- Clean the element in a well-ventilated area, and take care that there are no sparks or flame anywhere near the working area; this includes any appliance with a pilot light.
- Do not use gasoline or a low flash-point solvent to clean the element. A fire or explosion could result.
- ★If the sponge gasket comes loose, stick it back on with an adhesive sealant.
- Install the element.

.....
Air Cleaner Element

A clogged air cleaner restricts the engine's air intake, increasing fuel consumption, reducing engine power, and causing spark plug fouling.

"NOTE"

- In dusty areas, the element should be cleaned more frequently than the recommended interval.
- After riding through rain or on muddy roads, the element should be cleaned immediately.

Inspection and Cleaning

- Remove the air cleaner element.

"NOTE"

- Left side element is a dry type element, and right side is an oiled type element.

WARNING

- If dirt or dust is allowed to pass through into the carburetors, the throttle may become stuck, possibly causing an accident.

CAUTION

- If dirt gets through into the engine, excessive engine wear and possibly engine damage will occur.
- Inspect the element for damage.

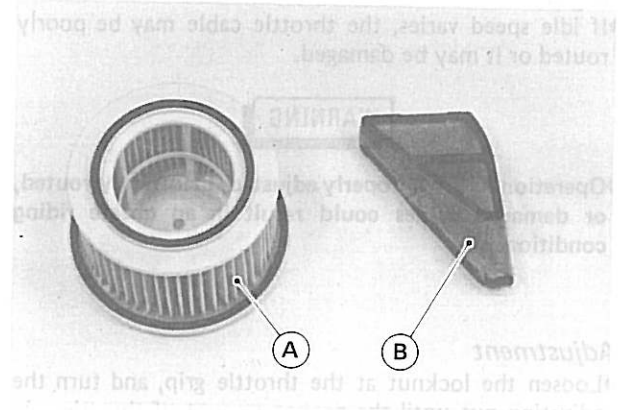

A. Left Side Element B. Right Side Element

Throttle Grip

The throttle grip controls the throttle valves. If the throttle grip has excessive play due to either cable stretch or maladjustment, it will cause a delay in throttle response, especially at low engine speed. Also, the throttle valves may not open fully at full throttle. On the other hand, the throttle grip has no play, the throttle will be hard to control, and the idle speed will be hard erratic.

Inspection

- Check that there is the proper throttle grip play when lightly turning the throttle grip back and forth.

Throttle Grip Play

Standard: 2 – 3 mm

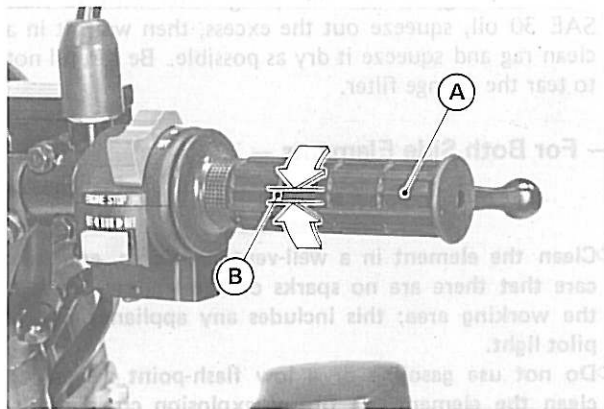

A. Throttle Grip B. Throttle Grip Play

- ★ If there is improper play, adjust it.
- Start the engine.
- Turn the handlebar from side to side while idling the engine.
- ★ If idle speed varies, the throttle cable may be poorly routed or it may be damaged.

WARNING

- Operation with improperly adjusted, incorrectly routed, or damaged cables could result in an unsafe riding condition.

Adjustment

- Loosen the locknut at the throttle grip, and turn the adjusting nut until the proper amount of throttle grip play is obtained. Tighten the locknut.

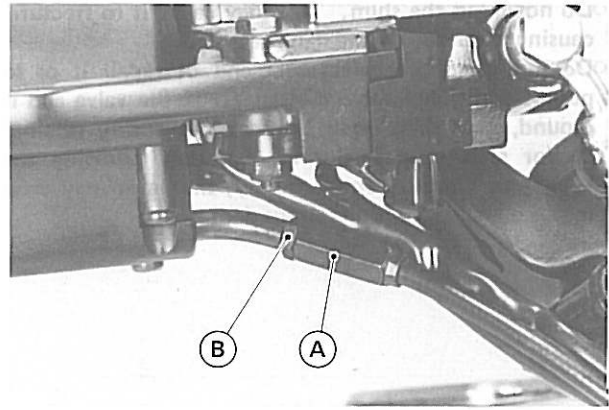

A. Adjusting Nut B. Locknut

Idle Speed

When the idle speed is too low, the engine may stall; when the idle speed is too high, the fuel consumption becomes excessive, and the resulting lack of engine braking may make the motorcycle difficult to control.

Inspection

- Thoroughly warm up the engine.
- With the engine idling, turn the handlebar to each side.
- ★ If handlebar movement changes the idle speed; the throttle cable may be improperly adjusted or incorrectly routed, or it may be damaged. Be sure to correct any of these conditions before riding.

WARNING

- Operation with improperly adjusted, incorrectly routed, or a damaged cable could result in an unsafe riding condition.
- Check that the idle speed is within the specified range.

Idle Speed

ZR400	1,200 ±50 r/min (rpm)
ZR500/550	1,050 ±50 r/min (rpm)

- ★ If the idle speed is out of the specified range, adjust it as follows.

Adjustment

- Turn the adjusting screw to adjust the idle speed.

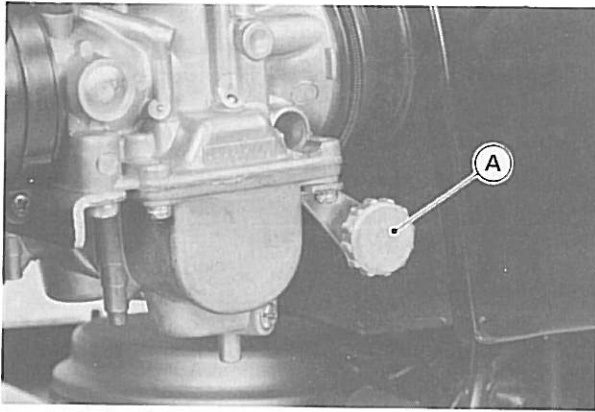

A. Idle Adjusting Screw

- Open and close the throttle a few times to make sure that the idle speed is within the specified range. Re-adjust if necessary.

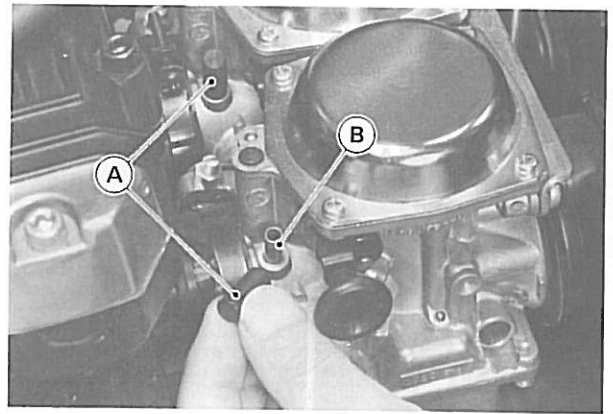

A. Rubber Caps

B. Fittings

- Set vacuum gauge 57001-1152 to the fittings in the manner prescribed on the vacuum gauge handling instruction.

CAUTION

- Read the vacuum gauge handling instruction before using the vacuum gauge to prevent any damage to it.

Engine Vacuum Synchronization

Poor engine vacuum synchronization will cause unstable idling, sluggish throttle response, and reduced engine power and performance.

Inspection

- Remove the fuel tank, and place it on a workbench of the same height as the motorcycle fuel tank location.
- Supply fuel from the tank to the carburetors by connecting a suitable fuel hose and vacuum hose.

WARNING

- Gasoline is extremely flammable and can be explosive under certain conditions. Do not smoke. Make sure the area is well ventilated and free from any source of flame or sparks; this includes any appliance with a pilot light.

- Start the engine, and warm it up thoroughly.
- Check the idle speed.
- Stop the engine.
- Pull off the vacuum hose for the fuel tap and the three fubber caps from the fittings.

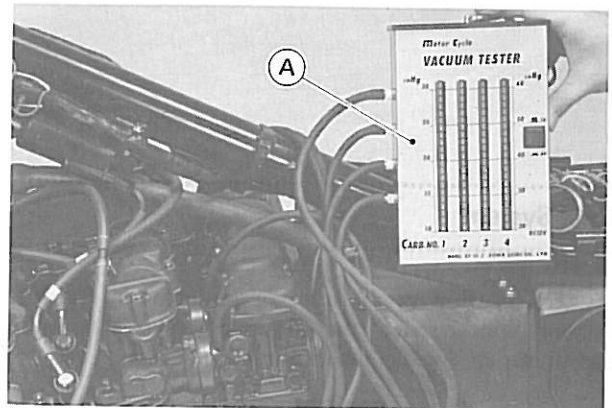

A. Vacuum Gauge

- With the engine running at idle speed, note the gauge readings.
- ★ If the difference in vacuum readings between two cylinders is greater than the specified value, adjust the engine vacuum synchronization.

Engine Vacuum

Less than 2.7 kPa (2 cm Hg)
Difference between two cylinders:

Adjustment

- To balance the vacuum, loosen the locknut, and turn the balance adjusting screw with Throttle Valve adjuster 57001-351. If the idle speed has been changed during synchronization, adjust the idle speed as necessary.

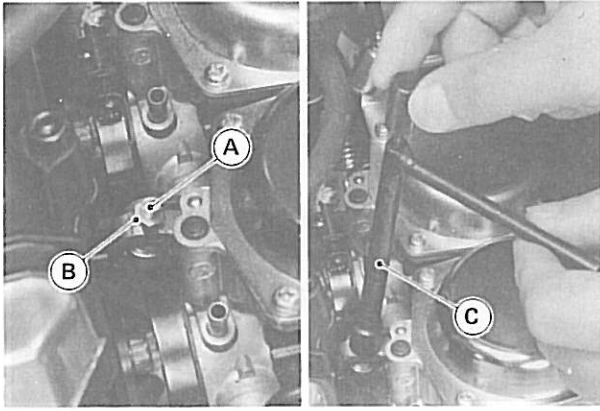

A. Balance Adjusting Screw C. Throttle Valve Adjuster
B. Locknut

- After the engine vacuum is properly synchronized, tighten the locknut without changing the position of the screw.

Fuel System

Accumulation of moisture or sediment in the fuel system will restrict the flow of fuel and cause carburetor and/or fuel tap malfunction.

WARNING

- Gasoline is extremely flammable and can be explosive under certain conditions. Turn the ignition switch OFF. Do not smoke. Make sure the area is well ventilated and free from any source of flame or sparks; this includes any appliance with a pilot light.
- Make sure the engine is cold before working. Wipe any fuel off the engine before starting it.

Inspection

- Connect a suitable hose to the fitting at the bottom of each carburetor float bowl.
- Run the lower ends of the hoses into a suitable container.
- Turn the fuel tap lever to the PRI position.
- Turn out each drain plug a few turns to drain the carburetors, and check to see if water or dirt comes out.
- ★ If any water or dirt comes out, clean the fuel system.
- Tighten the drain plug securely, and remove the hose.

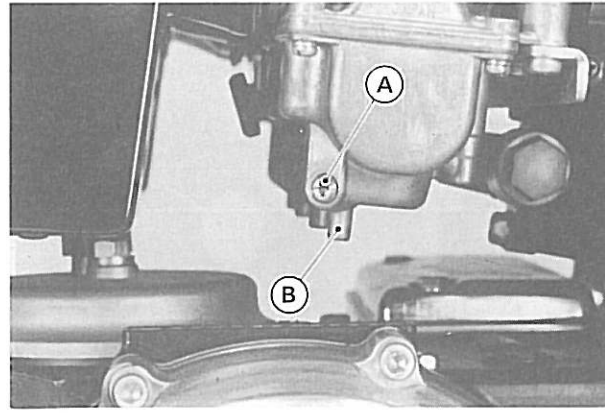

A. Drain Plug B. Fitting

Cleaning

- Remove the fuel tank, and remove the fuel tap and fuel level sensor from the tank.
- Flash out the fuel tank with a high flash-point solvent.
- Wash the fuel filter on the fuel tap clean of dirt with a high flash-point solvent.
- Remove the carburetors, and disassemble them to clean the fuel and air passages.

CAUTION

- Remove the diaphragms and floats before cleaning the carburetors with compressed air, or they will be damaged.
- Do not use a strong carburetor cleaning solution which could attack rubber or plastic parts; instead, use a mild cleaning solution safe for these parts.
- Do not use wire for cleaning as this could damage the jets.
- Wash the disassembled parts, and air and fuel passages with a high flash-point solvent. If necessary, use a bath of automotive type carburetor cleaner.
- Blow the jets, and air and fuel passages clean with compressed air.

Engine Oil

In order for the engine, transmission, and clutch to function properly; change the engine oil and oil filter, and maintain the oil at the proper level. Not only do dirt and metal particles collect in the oil, but the oil itself loses its lubricative quality if used too long.

WARNING

- Motorcycle operation with insufficient, deteriorated, or contaminated engine oil will cause accelerated wear and may result in engine or transmission seizure, accident, and injury.

Oil Change

- Warm up the engine that the oil will pick up any sediment and drain easily. Then stop the engine.

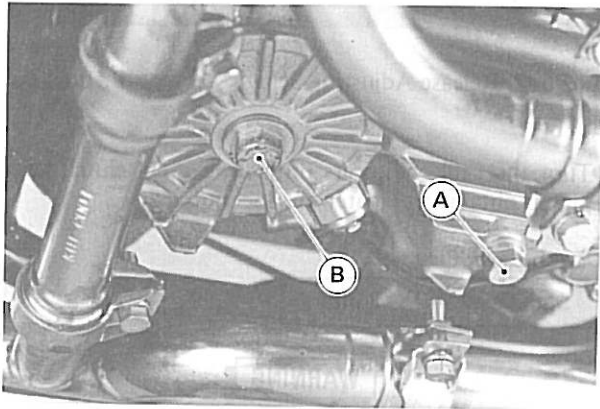

A. Drain Plug B. Oil Filter Mounting Bolt

- With the motorcycle perpendicular to the ground, let the oil completely drain.
- If the oil filter is to be changed, replace it with a new one.
- Check the gasket at the drain plug for damage. Replace the gasket with a new one if it is damaged.
- After the oil has completely drained out, install the engine drain plug with its gasket, and tighten it to the specified torque.

Tightening Torque

Engine Drain Plug: 29 N-m (3.0 kg-m, 22 ft-lb)

Engine Oil:

Grade:	SE Class
Viscosity:	SAE 10W40, 10W50, 20W40 or 20W50
Required Amount	
When filter is not removed:	2.6 L
When filter is removed:	3.0 L

Oil Level Inspection

- If the oil has just been changed, start the engine and run it for several minutes at idle speed. This fills the oil filter with oil. Stop the engine, then wait several minutes until the oil settles.

CAUTION

- Racing the engine before the oil reaches every part can cause engine seizure.

- If the motorcycle has just been used, wait several minutes for all the oil to drain down.
- Situate the motorcycle so that it is perpendicular to the ground, and check the engine oil level through the oil level gauge.
- The oil level should come up between the upper and lower levels.
- If the oil level is too high, remove the excess oil, using a syringe or some other suitable device.
- If the oil level is too low, add the correct amount of oil through the oil filler opening. Use the same type and make of oil that is already in the engine.

"NOTE"

- If the oil must be refilled but the type and brand of the oil that is already in the engine are unidentified, change the oil in the engine completely.

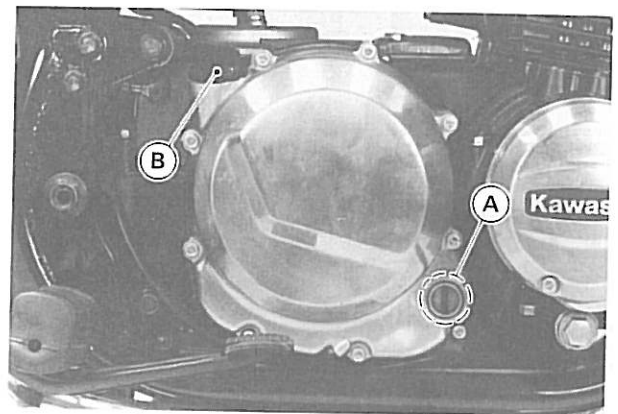

A. Level Gauge B. Oil Filler Opening Cap

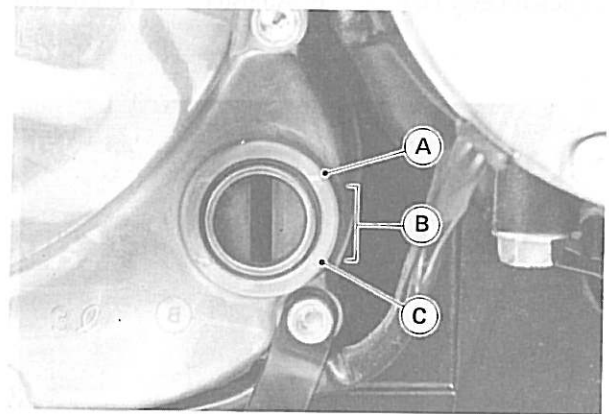

A. Upper Level C. Lower Level
B. Proper Level Range

CAUTION

- If the engine oil gets extremely low or if the oil pump or oil passages clog up or otherwise do not function properly, the oil pressure warning light will light. If this light stays on when the engine speed is above 1,200 r/min (rpm), stop the engine immediately and find the cause.

Clutch

Due to the friction plate wear and the clutch cable stretch over a long period of use, the clutch must be adjusted in accordance with the Periodic Maintenance Chart.

WARNING

- To avoid a serious burn, never touch the engine or exhaust pipes during clutch adjustment.

Adjustment

- Remove the clutch release adjusting cover.
- Loosen the locknuts, and turn in fully the clutch cable adjusters to give the cable plenty of play.

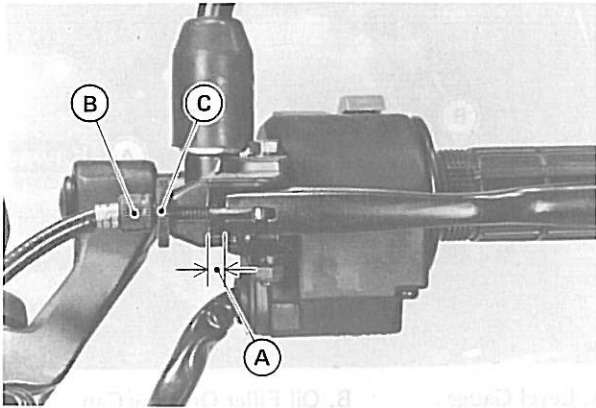

A. Clutch Lever Play B. Adjuster C. Locknut

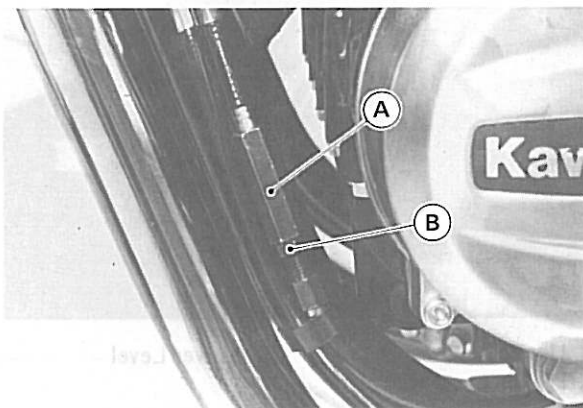

A. Adjuster B. Locknut

- Loosen the locknut, and turn the clutch release adjusting screw counterclockwise until it becomes hard to turn.
- Turn the release adjusting screw clockwise $\frac{1}{4}$ turn from that point, and tighten the locknut.
- Install the clutch release cover.

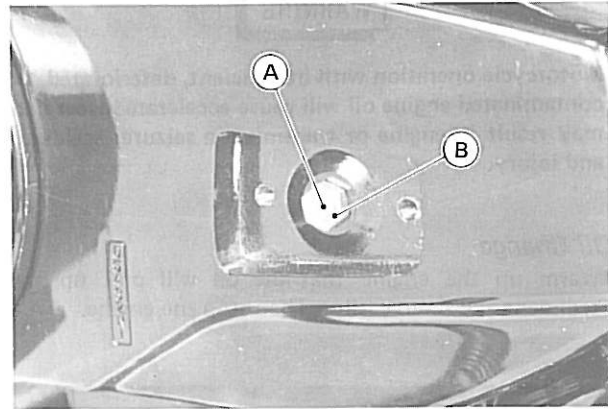

A. Clutch Release Adjusting Screw B. Locknut

- Turn the cable adjusters until the correct clutch lever play is obtained. Tighten the locknuts.

Clutch Lever Play

Standard: 2 – 3 mm

WARNING

- Be sure each end of the clutch outer cable is fully seated in its fitting, or it could slip into place later, creating enough cable play to prevent clutch disengagement, resulting in a hazardous riding condition.
- After the adjustment is made, start the engine and check that the clutch does not slip and that it releases properly.

Drive Chain

The drive chain must be checked, adjusted, and lubricated for safety and to prevent excessive wear. If the chain becomes badly worn or maladjusted – either too loose or too tight – the chain could jump off the sprockets or break.

WARNING

- A chain that breaks or jumps off the sprockets could snag on the engine sprocket or lock the rear wheel, severely damaging the motorcycle and causing it to go out of control.

Slack Inspection

- Set the motorcycle up on its center stand.
- Rotate the rear wheel to find the position where the chain is tightest, and measure the vertical movement midway between the sprockets.
- ★If the drive chain slack is out of the usable range, adjust it so that the chain slack will be within the standard value.

Drive Chain Slack

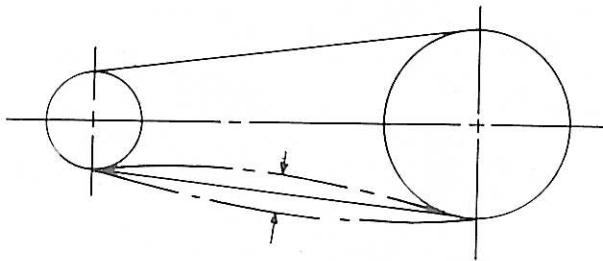

Drive Chain Slack

Standard	30 – 35 mm
Too tight or too loose	Less than 30 mm more than 40 mm

Slack Adjustment

- Loosen the rear torque link nut.

CAUTION

- If you don't loosen the torque link nut, it may lead to the brake parts damage when the adjusters are set.

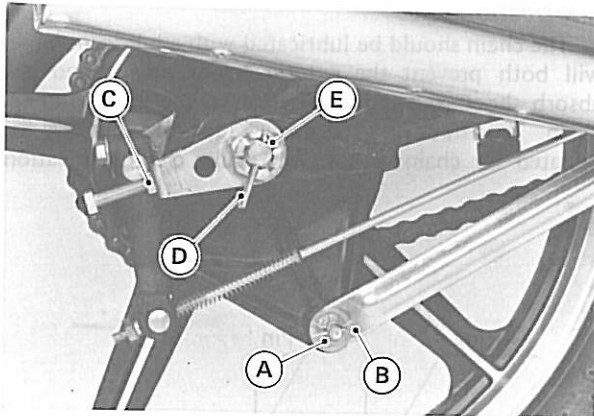

- A. Torque Link Nut
- B. Safety Clip
- C. Chain Adjuster Locknut
- D. Axle Nut Cotter Pin
- E. Axle Nut

- Loosen the left and right chain adjuster locknuts.
- Remove the cotter pin, and loosen the axle nut.
- If the chain is too tight, back out the left and right chain adjusting bolts evenly, and kick the wheel forward until the chain is too loose.
- Turn both chain adjusting bolts evenly until the drive chain has the correct amount of slack. To keep the chain and wheel properly aligned, the notch on the left chain adjuster should align with the same swing arm mark that the right chain adjuster notch aligns with.

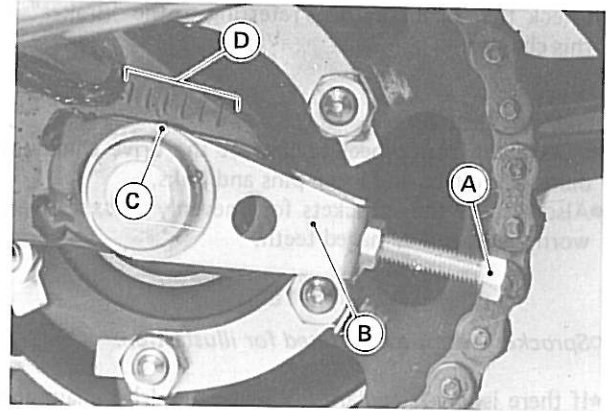

- A. Adjusting Bolt
- B. Chain Adjuster
- C. Notch
- D. Swing Arm Marks

"NOTE"

- Wheel alignment can also be checked using the straightedge or string method.

WARNING

- Misalignment of the wheel will result in abnormal wear, and may result in an unsafe riding condition.

- Tighten both chain adjuster locknuts.
- Center the brake panel assembly in the brake drum. This is done by tightening the axle nut lightly, spinning the wheel, and depressing the brake pedal forcefully. The partially tightened axle nut allows the brake panel assembly to center itself within the brake drum.

"NOTE"

- This procedure can prevent a soft, or "spongy feeling" brake. Tighten the axle nut to the specified torque.

Tightening Torque

Axle Nut	78 N-m (8.0 kg-m, 58 ft-lbs)
Torque Link Nut	29 N-m (3.0 kg-m, 22 ft-lbs)

- Rotate the wheel, measure the chain slack again at the tightest position, and readjust if necessary.
- Insert a new cotter pin through the axle nut and axle, and spread its ends.
- Tighten the rear torque link nut to the specified torque.

WARNING

- If the axle and torque link nuts are not securely tightened and the cotter pin is not installed and the safety clip is not installed, an unsafe riding condition may result.

- Check the rear brake play referring to the “Brakes” in this chapter.

Wear Inspection

- Rotate the rear wheel to inspect the drive chain for damaged rollers, and loose pins and links.
- Also inspect the sprockets for unevenly or excessively worn teeth, and damaged teeth.

“NOTE”

○ Sprocket wear is exaggerated for illustration.

- ★ If there is any irregularity, replace the drive chain and both sprockets.

Sprocket Teeth

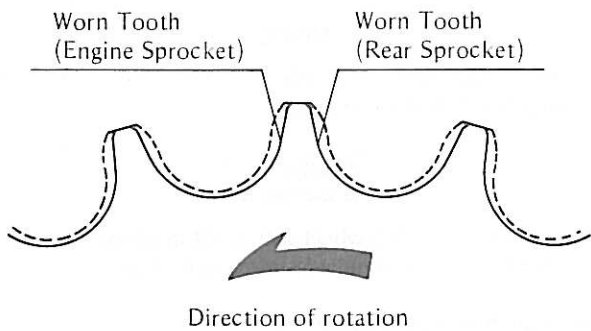

- Stretch the chain taut hanging a 98 N (10 kg, 20 lb) weight on the chain.
- Measure the length of 20 links on the straight part of the chain from pin center of the 1st pin to pin center of the 21st pin. Since the chain may wear unevenly, take measurements at several places.

Drive Chain

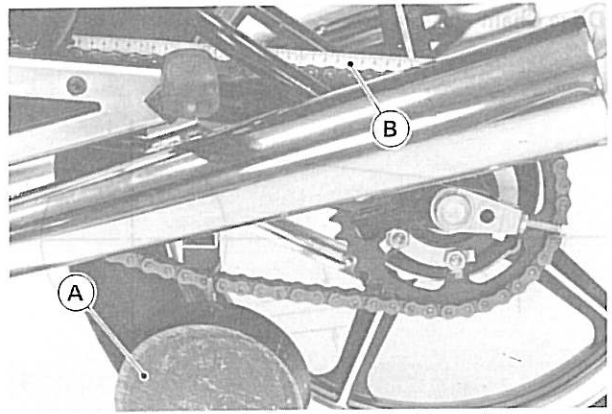
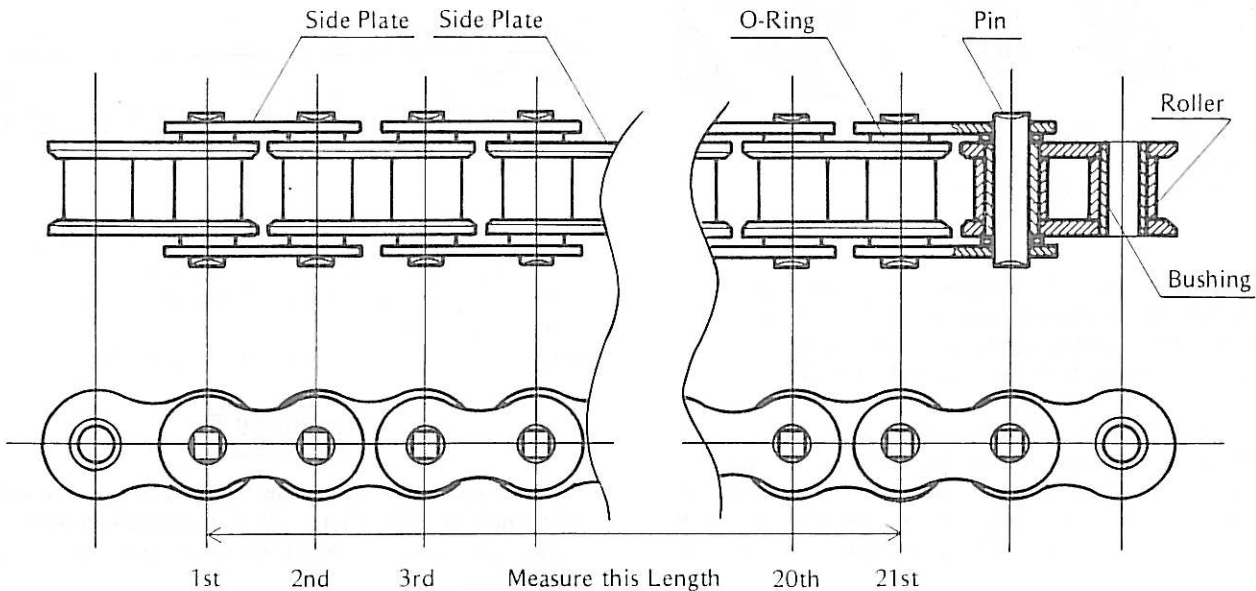

A. Weight

B. Measure

- ★ If any measurements exceeds the service limit, replace the chain. Also, replace the engine and rear sprockets when the drive chain is replaced.

WARNING

- For safety, use only the standard chain. It is an endless type and should not be cut for installation.

Drive Chain 20-Link Length

Service Limit : 323 mm

Lubrication

The chain should be lubricated with a lubricant which will both prevent the exterior from rusting and also absorb shock and reduce friction in the interior of the chain. An effective, good quality lubricant specially formulated for chains is best for regular chain lubrication.

If a special lubricant is not available, a heavy oil such as SAE 90 is preferred to a lighter oil because it will stay on the chain longer and provide better lubrication.

- If the chain appears especially dirty, it should be cleaned before lubrication.

CAUTION

- The O-rings between the side plates seal in the lubricant between the pin and the bushing. To avoid damaging the O-rings and resultant loss of lubricant, observe the following rules.
- Use only kerosene or diesel oil for cleaning an O-ring drive chain. Any other cleaning solution such as gasoline or trichloroethylene will cause deterioration and swell of the O-rings.
- Immediately blow the chain dry with compressed air after cleaning.
- Complete cleaning and drying the chain within 10 minutes.
- Apply oil to the sides of the rollers so that oil will penetrate to the rollers and bushings. Apply the oil to the O-rings so that the O-rings will be coated with oil.

- ★ If the pedal has improper play, adjust it.
- Operate the pedal a few times to see that it returns to its rest position immediately upon release.
- Rotate the front and rear wheels to check for brake drag.
- Check braking effectiveness.
- ★ If there is any doubt as to the conditions of the brakes, check the brake parts for wear or damage.

Rear Brake Adjustment

- Loosen the brake pedal adjusting bolt locknut, turn the adjusting bolt at the brake panel so that the pedal has proper play.

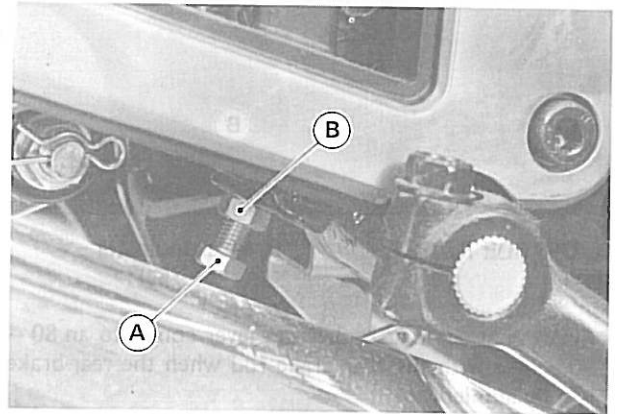

A. Adjusting Bolt B. Adjusting Bolt Locknut

Brakes

Brake Play:

Inspection

- Check that the rear brake pedal has specified play when the pedal is pushed down lightly by hand.

Brake Pedal Play

Standard:	20 – 30 mm
-----------	------------

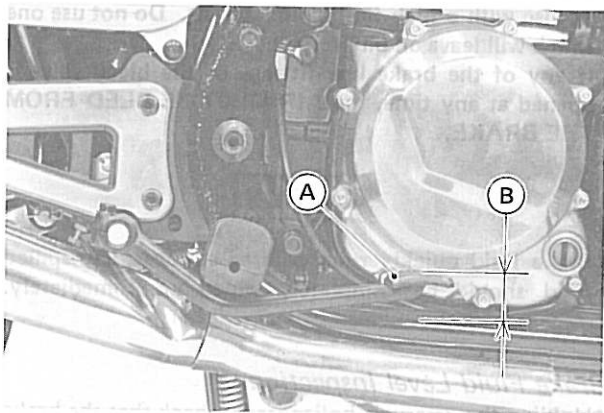

A. Rear Brake Pedal B. Play

Brake Lining Wear:

Front Brake:

Inspection

- Check the lining thickness of the pads in each caliper.
- ★ If the lining thickness of either pads is less than the service limit, replace both pads in the caliper as a set.

Pad Lining Thickness

Standard	4.5 mm
Service Limit	1 mm

Brake Pad

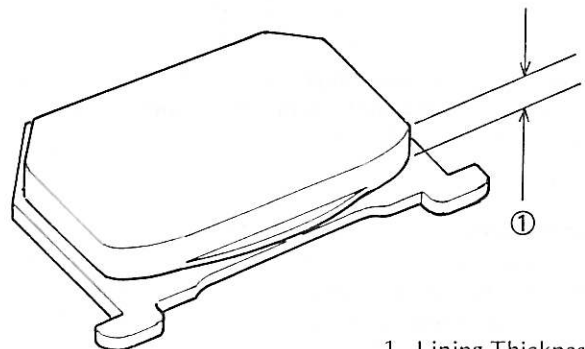

1. Lining Thickness

Rear Brake:*Inspection*

- Check the rear brake lining wear indicator points within the **USABLE RANGE** when the rear brake is fully applied.
- ★ If does not, the brake shoes must be immediately replaced and the other brake parts examined.

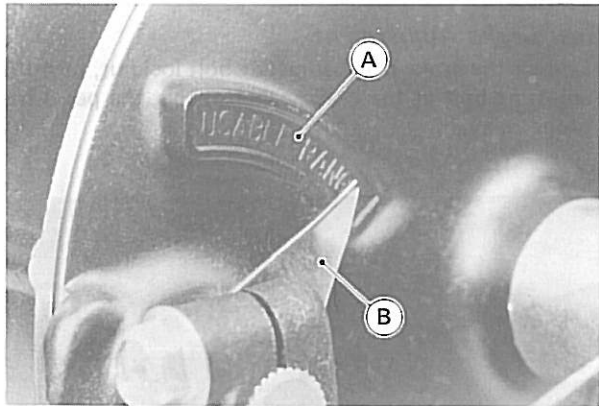

A. USABLE RANGE

B. Wear Indicator

- Check that the rear brake cam lever comes to an 80 – 90° angle with the rear brake rod when the rear brake is fully applied.
- ★ If it does not, adjust the rear brake cam lever angel.

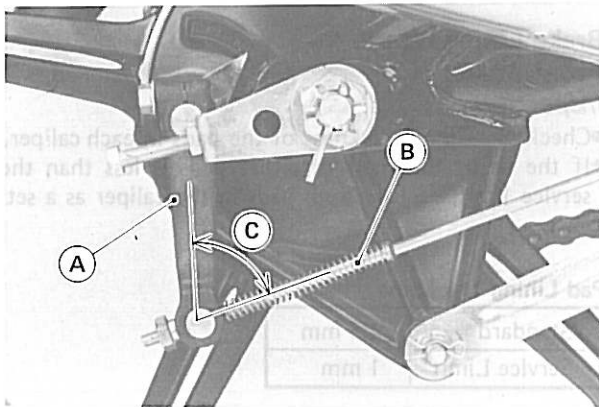

A. Cam Lever

B. Brake Rod

C. 80 – 90°

WARNING

- Since a cam lever angle greater than 90° reduces braking effectiveness, cam lever angle adjustment should not be neglected.

Cam Lever Angle Adjustment

- Remove the bolt and nut, and take off the cam lever.
- Mount the cam lever at a new position so that the cam lever has a proper angle when the brake is fully applied.
- Adjust the brake play.

WARNING

- When remounting the cam, be sure that the position of the indicator on the serrated shaft is not altered.
- A change in cam lever angle is caused by wear of internal brake parts. Whenever the cam lever angle is adjusted, also check for drag and proper operation, taking particular note of the brake lining wear indicator position.
- In case of doubt as to braking effectiveness, disassemble and inspect all internal brake parts. Worn parts could cause the brake to lock or fail.

Brake Fluid:

Recommended fluids are given in the table below. If none of the recommended brake fluids are available, use extra heavy-duty brake fluid only from a container marked D.O.T.3.

Recommended Disc Brake Fluid

Brand:	Atlas Extra Heavy Duty
	Shell Super Heavy Duty
	Texaco Super Heavy Duty
	Wagner Lockheed Heavy Duty
	Castrol Girling-Universal
	Castrol GT (LMA)
	Castrol Disc Brake Fluid

WARNING

- Never reuse old brake fluid.
- Do not use fluid from a container that has been left unsealed or that has been open for a long time.
- Do not mix two types and brands of fluid for use in the brake. This lowers the brake fluid boiling point and could cause the brake to be ineffective. It may also cause the rubber brake parts to deteriorate.
- Don't leave the reservoir cap off for any length of time to avoid moisture contamination of the fluid.
- Don't add or change the fluid in the rain or when a strong wind is blowing.
- Clean off any fluid that inadvertently gets on the pads or disc with a high flash-point solvent. Do not use one which will leave an oily residue.
- If any of the brake line fittings or the bleed valve is opened at any time, the **AIR MUST BE BLED FROM THE BRAKE.**

CAUTION

- Brake fluid quickly ruins painted surfaces; any spilled fluid should be completely wiped up immediately.

Brake Fluid Level Inspection

- Holding the reservoir horizontal, check that the brake fluid level in the reservoir is higher than the lower level.

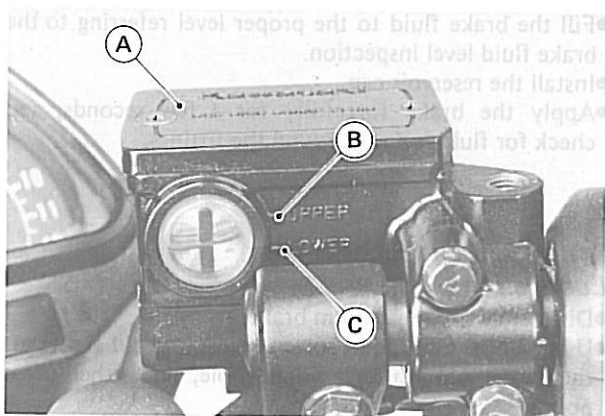

A. Reservoir
B. Upper Level
C. Lower Level

★If the fluid level is lower than the lower level, check the fluid leakage of the brake line, and add the brake fluid as follows.

○Remove the reservoir cap, and fill the reservoir to the upper level with the same type and brand of brake fluid that already is in the reservoir. And then install the reservoir cap.

WARNING

○Change the brake fluid in the brake line completely if the brake fluid must be refilled but the type and brand of the brake fluid that already is in the reservoir are unidentified.

○After changing the fluid, use only the same type and brand of fluid thereafter.

●Apply the brake forcefully for a few seconds, and check for fluid leakage around the fittings.

WARNING

○If the brake has a soft or “spongy feeling” when it is applied, there might be air in the brake lines or the brake may be defective. Since it is dangerous to operate the motorcycle under such conditions, bleed the air from the brake line immediately.

Brake Fluid Change

- Remove the reservoir cap, and remove the rubber cap on the bleed valve.
- Attach a clear plastic hose to the bleed valve on the caliper, and run the other end of the hose into a container.
- Open the bleed valve (counterclockwise to open), and pump the brake lever until all the fluid is drained from the line.
- Close the bleed valve.
- Repeat the above four steps one more time for the other side caliper.
- Fill the reservoir with fresh brake fluid.

- Open the bleed valve, apply the brake by the brake lever, close the valve with the brake held applied, and then quickly release the lever. Repeat this operation until the brake line is filled and fluid starts coming out of the plastic hose.
- Repeat the above one step one more time for the other side caliper.

“NOTE”

○Replenish the fluid in the reservoir as often as necessary to keep it from running completely out.

●Bleed the air from the line.

Filling Up the Brake Line

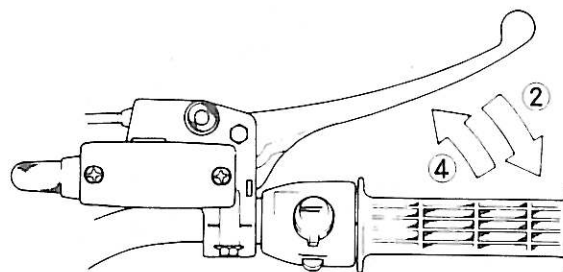
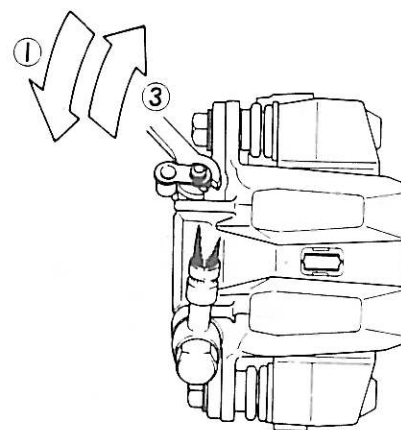

1. Open the bleed valve.
2. Apply the brake, keeping the brake applied.
3. Close the bleed valve.
4. Then quickly release the brake.

Brake Line Air Bleeding

- Remove the reservoir cap, and check that there is plenty of fluid in the reservoir.
- With the reservoir cap off, slowly pump the brake lever several times until no air bubbles can be seen rising up from the bottom of the reservoir. This bleeds the air from the master cylinder end of the line.
- Install the reservoir cap.
- Remove the rubber cap on the bleed valve.

- Attach a clear plastic hose to the bleed valve on the caliper, running the other end of the hose into a container.
- Pump the brake lever a few times until it becomes hard and then, holding the lever squeezed, quickly open (turn counterclockwise) and close the bleed valve. Then release the lever. Repeat this operation until no more air can be seen coming out into the plastic hose.
- Repeat the above two steps one more time for the other side caliper.

"NOTE"

○ The fluid level must be checked several times during the bleeding operation and replenished as necessary. If the fluid in the reservoir runs completely out any time during bleeding, the bleeding operation must be done over again from the beginning since air will have entered the line.

Air Bleeding

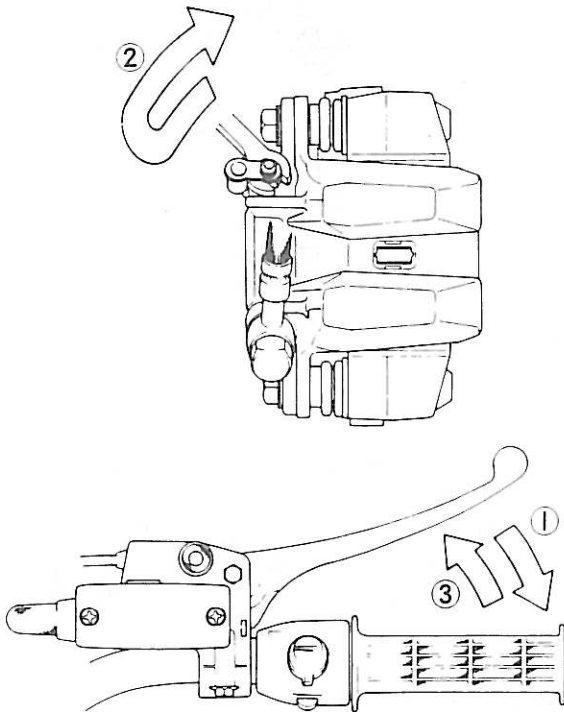

1. Hold the brake applied.
2. Quickly open and close the valve.
3. Release the brake.

- Install the rubber cap on the bleed valve.
- Tighten the bleed valve to the specified torque.

Tightening Torque

Tightening Torque	7.8 N-m (0.8 kg-m, 69 in-lbs)
-------------------	-------------------------------

- Fill the brake fluid to the proper level referring to the brake fluid level inspection.
- Install the reservoir cap.
- Apply the brake forcefully for a few seconds, and check for fluid leakage around the fittings.

Brake Camshaft Lubrication:
Lubrication

- Disassemble the rear drum brake.
- Using a high flash-point solvent, clean the old grease off the brake camshaft, camshaft hole, and other pivot points.
- * Replace the drum brake parts if they show wear or damage.
- Apply grease to the brake pivot points (brake shoe anchor pin, spring ends, and cam surface of the camshaft) and fill the camshaft groove with grease. Do not get any grease on the brake shoe linings, and wipe off any excess grease so that it will not get on the linings or drum after brake assembly.

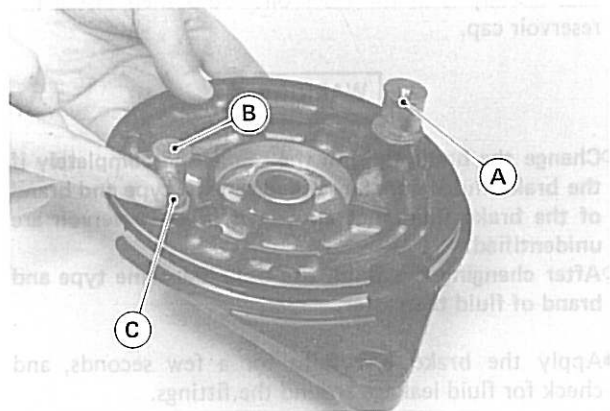

A. Brake Camshaft B. Anchor Pin C. Grease.

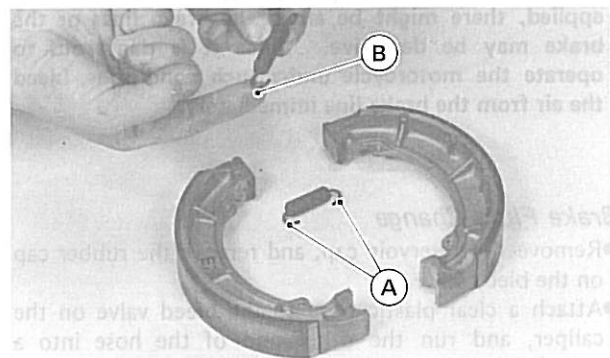

A. Spring Ends B. Grease.

- Assemble the rear drum brake.
- Adjust the brake play.

Steering

If the steering is too tight, it will be difficult to turn the handlebar quickly, the motorcycle may pull to one side, and the steering stem bearings may become damaged. If the steering is too loose, the handlebar will vibrate and the motorcycle will be unstable and difficult to steer in a straight line.

Inspection

- Raise the front wheel off the ground.
- Inspect steering tightness.
 - From the straightforward position of the handlebar, slowly push the handlebar to either side.
 - ★ If the handlebar begins to turn by the action of gravity and continues moving until the ridge on the stem base stops against the stop plate on the frame head pipe, the steering is not too tight.
 - ★ If the handlebar does not begin to turn by the action of gravity, the steering is too tight necessitating adjustment.
- Inspect steering play.
 - Squat in front of the motorcycle and grasp the lower ends of the front fork. Push and pull the fork end back and forth.
 - ★ If play is felt, the steering is too loose, necessitating adjustment.

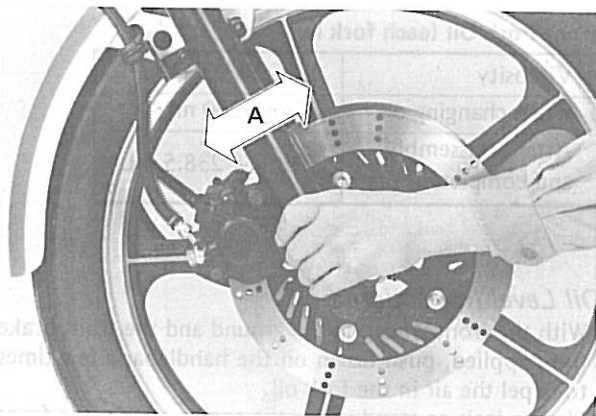

A. Push and pull the front fork.

Adjustment

- Remove the fuel tank.
- Loosen the front fork upper clamp bolts(2) to free the fork tubes from the steering stem during adjustment.

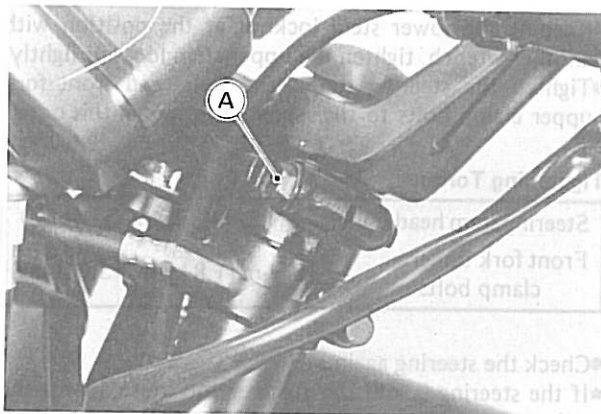

A. Front fork upper clamp bolts

- Loosen the steering stem head bolt.

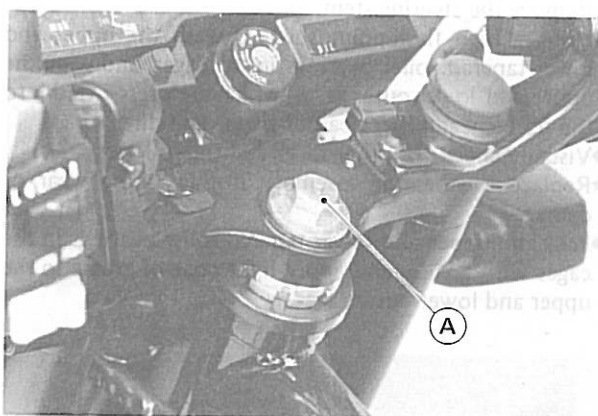

A. Stem Head Bolt

- Loosen the upper stem locknut using stem nut wrench (special tool).

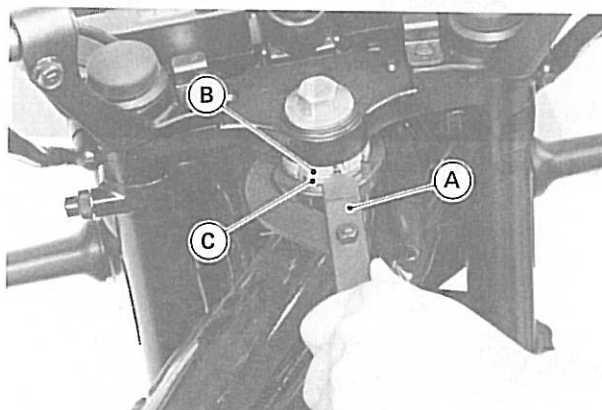

A. Wrench: 57001-1100
B. Upper Stem Locknut
C. Lower Stem Locknut

- If the steering is too tight, loosen the lower stem locknut a fraction of turn; if the steering is too loose, tighten the locknut a fraction of turn. Turn the locknut a $\frac{1}{8}$ turn at maximum at a time.

- Keeping the lower stem locknut at the position with another wrench, tighten the upper stem locknut lightly.
- Tighten the steering stem head bolt, and front fork upper clamp bolts to the specified torque in this order.

Tightening Torque

Steering stem head bolt	42.N-m (4.3 kg-m, 31 ft-lbs)
Front fork upper clamp bolts	18 N-m (1.8 kg-m, 13.0 ft-lbs)

- Check the steering again.
- ★ If the steering is still too tight or too loose, repeat the adjustment. If the proper condition cannot be obtained in spite of correct adjustment, inspect the steering parts.
- Remount the fuel tank.

Lubrication

- Remove the steering stem.
- Using a high flash-point solvent, wash the upper and lower tapered roller bearings in the cages, and wipe the upper and lower outer races, which are press-fitted into the frame head pipe, clean of grease and dirt.
- Visually check the outer races and the rollers.
- ★ Replace the bearing assembly if they show wear or damage.
- Pack the upper and lower tapered roller bearings in the cages with grease, and apply light coat of grease to the upper and lower outer races.

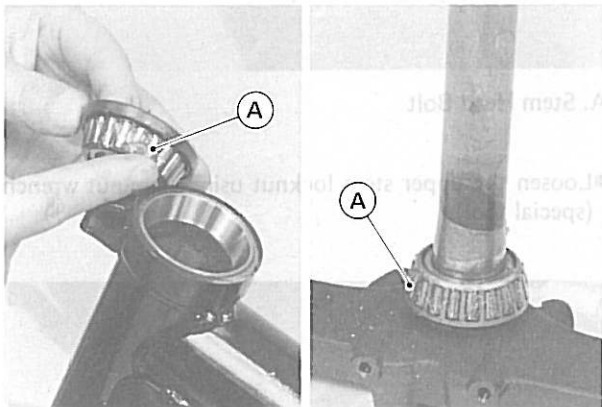

A. Tapered Roller Bearings

Fork Oil

Oil Change

Contaminated or deteriorated fork oil will affect shock damping and, in addition, will accelerate internal wear. Therefore the fork oil should be changed.

- Release fork air pressure.
- Remove the drain bolt to drain the oil.

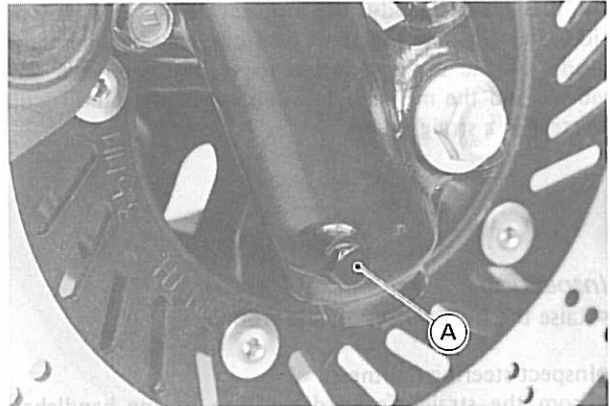

A. Drain Plug

- With the front wheel on the ground and the front brake fully applied, push down on the handlebar a few times to pump out the oil.
- Place a jack or stand under the engine so that the front wheel is raised off the ground.
- Apply a non-permanent locking agent the thread, and install the drain bolt and gasket.
- Tighten the drain bolt to the specified torque.
- Remove the top plug from the top of the fork leg inner tube, and fill the fork leg with the specified oil.
- Install the top plug.
- Change the fork oil in the other fork leg in the same manner.
- Check the oil level in each fork leg.

Front Fork Oil (each fork leg)

Viscosity	SAE 5W20
When changing oil	About 200 mL
After disassembly and completely dry	233.5 – 238.5 mL

Oil Level Inspection

- With the front wheel on the ground and the front brake fully applied, push down on the handlebar a few times to expel the air in the fork oil.
- Place a jack or stand under the engine so that the front wheel is raised off the ground.
- Release fork air pressure.
- Remove the top plugs from both left and right fork leg inner tubes, and remove the springs in the inner tubes.
- With the fork fully extended, insert a tape measure or thin rod in the inner tube, and measure the distance from the top of the inner tube to the oil. Measure both fork legs.
- ★ If the oil is above or below the specified level; remove or add oil, and recheck the oil level.

- Install the removed parts, and pressurize the fork to the specified level.

Front Fork Oil Level

495 ±2 mm below from the top end of the inner tube

Tire Tread Depth

Tread Depth of New Tire:

Front	ZR400	3.4 mm
	ZR500/550	3.5 mm
	Service Limit	1 mm
Rear	ZR400	6.9 mm
	ZR500/550	7.3 mm
	Service Limit	2 mm

Standard Tire

Front	Size	ZR400	90/90-19 52S
		ZR500/550	3.25H19-4PR
Front	Make & Type	ZR400	Dunlop F14
		ZR500/550	Dunlop F8 MKII or Bridgestone L303A
Rear	Size	ZR400	110/90-18 61S
		ZR500/550	4.00H18-4PR
Rear	Make & Type	ZR400	Dunlop K130
		ZR500/550	Dunlop K427 or Bridgestone S716A

.....
Wheels
.....

Tires:

As the tire tread wears down, the tire becomes more susceptible the puncture and failure. An accepted estimate is that 90% of all tire failures occur during the last 10% of tread life (90% worn). So it is false economy and unsafe to use the tires until they are bald.

Tire Wear Inspection

- Remove any imbedded stones or other foreign particles from the tread.
- Visually inspect the tire for cracks and cuts, replacing the tire in case of bad damage. Swelling or high spots indicate internal damage, requiring tire replacement.
- Measure the tread depth at the center of the tread with a depth gauge. Since the tire may wear unevenly, take measurements at several places.
- ★ If any measurement is less than the service limit, replace the tire.

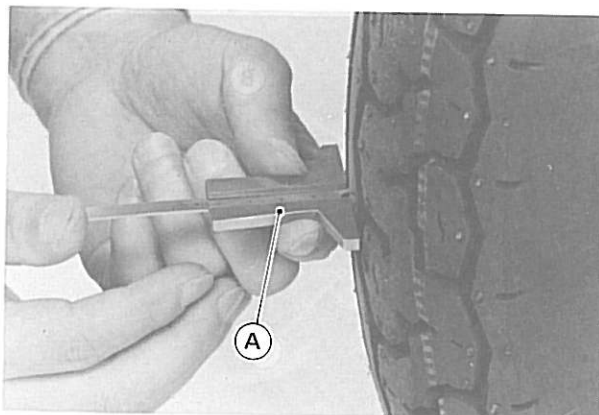

A. Tire Depth Gauge

WARNING

- To ensure safe handling and stability, use only the recommended standard tires for replacement, inflated to the standard pressure.
- Do not install tube-type tires on tubeless rims. The beads may not seat properly on the rim causing tire deflation.
- Do not install a tube inside a tubeless tire. Excessive heat build-up may damage the tube causing tire deflation.

"NOTE"

- Check and balance the wheel when a tire is replaced with a new one.
- Tires and rims specially designed for tubeless use have the indications of TUBELESS on the tire and the rim.

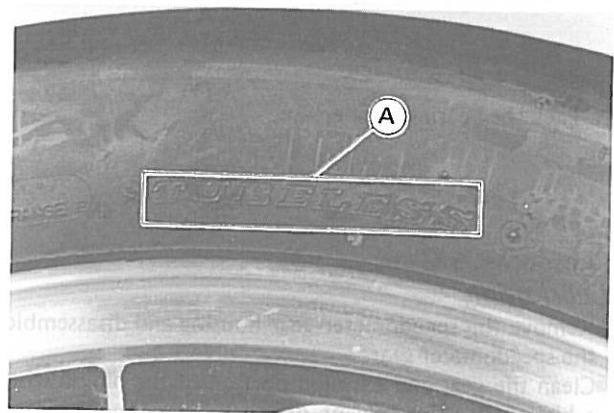

A. TUBELESS (on the tire side wall)

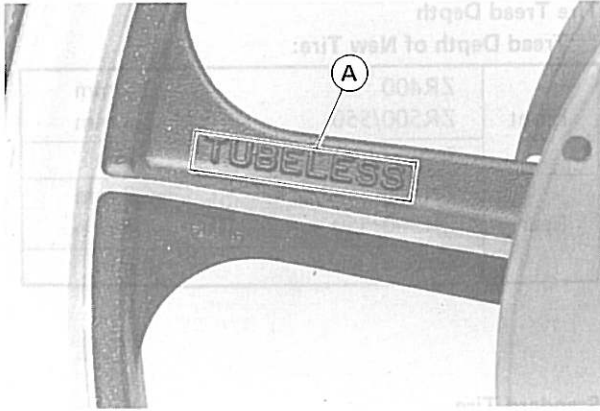

A. TUBELESS (on the rim)

Wheel Bearings:

Lubrication

- Remove the wheel bearings.
- Wipe the old grease out of the hub before bearing installation.
- Wash the bearings with a high flash-point solvent, and dry them (do not spin it while it is dry).
- Inspect the bearings for damage, replace any damaged bearing.
- Pack the bearings with good quality bearing grease. Turn the bearing around by hand a few times to make sure the grease is distributed uniformly inside the bearing.

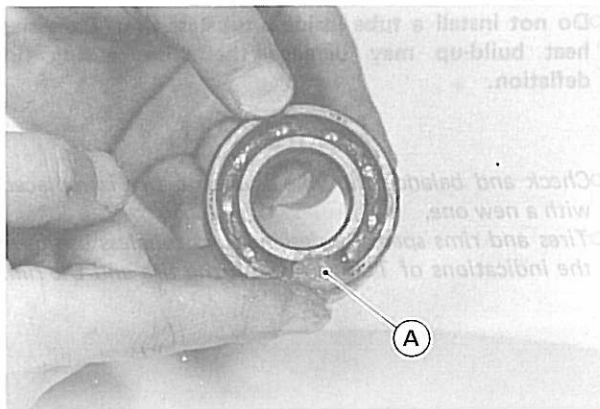

A. Pack the bearing with grease.

Speedometer Gear:

Lubrication

- Remove the speedometer gear housing and disassemble the speedometer gear.
- Clean the gear and exposed portion of the pinion with a high flash-point solvent, dry them, and apply a grease to the gear teeth and inside of the gear sleeve.

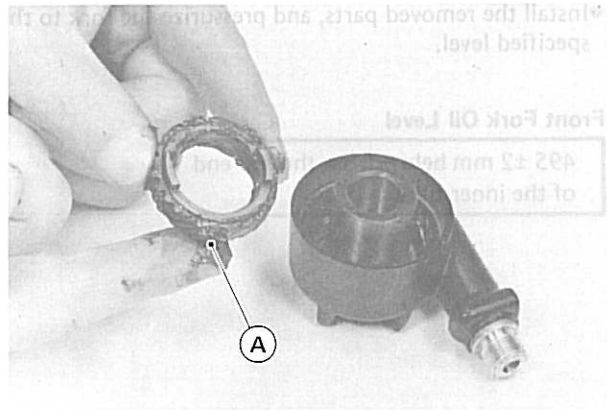

A. Grease.

- Assemble the speedometer gear and install the speedometer gear housing.

Swing Arm Uni-Trak

Lubrication

- Remove the swing arm and uni-trak, and pull out the sleeves.
- Wipe the old grease off the inner circumference of the bushings.
- Using a high flash-point solvent, wash the sleeves clean of grease, and dry them.
- Inspect the sleeves and bushings for abrasions, color change, or other damage.
- ★ If there is any doubt as to the condition of them, replace them with new ones.
- Apply a molybdenum disulfide chassis assembly grease to the outer circumference of the sleeves.

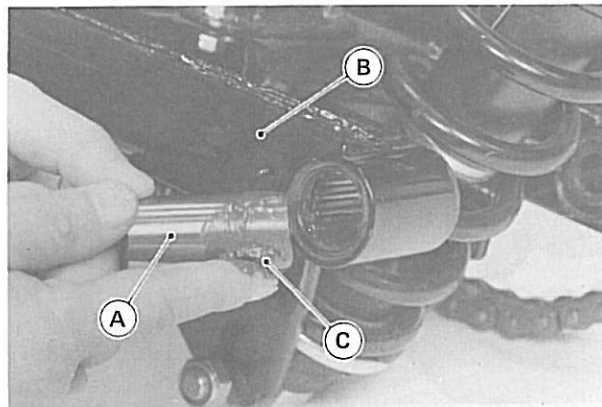

A. Sleeve B. Swing Arm C. Grease

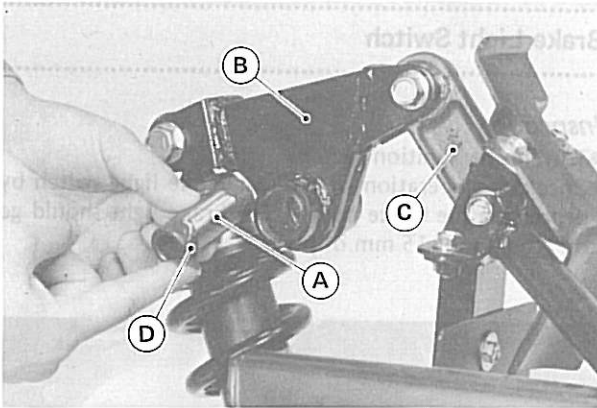

A. Sleeve
 B. Rocker Arm
 C. Tie Rod
 D. Grease

- Route the battery vent hose as shown on the "CAUTION" label.

CAUTION

- Make sure the battery vent hose is kept away from the drive chain. Battery electrolyte can corrode and dangerously weaken the chain.
- Do not let the vent hose become folded, pinched, or melted by the exhaust system. An unvented battery will not keep a charge and it may crack from built-up gas pressure.

.....
Battery

Battery Electrolyte Level Inspection

- Remove the battery.
- Check that the electrolyte level in each cell is between the upper and lower level lines.

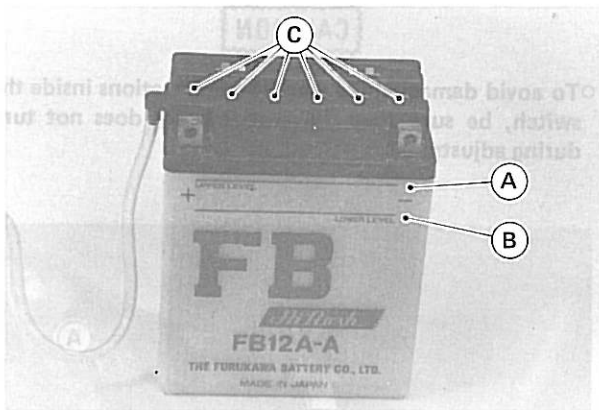

A. Upper Level Line
 B. Lower Level Line
 C. Filler Caps

*If the electrolyte level is low in any cell, fill with distilled water until the electrolyte level in each cell reaches the upper level line.

CAUTION

- Add only distilled water to the battery. Ordinary tap water is not substitute for distilled water and will shorten the life of the battery.
- Install the battery filler caps.

.....
General Lubrication

Lubrication

- Before lubricating each part, clean off any rusty spots with rust remover and wipe off any grease, oil, dirt, or grime.
- Lubricate the points listed below with indicated lubricant.

"NOTE"

○Whenever the vehicle has been operated under wet or rainy conditions, or especially after using a highpressure spray water, perform the general lubrication.

Apply motor oil to the following pivot points:

- Center stand
- Clutch lever
- Front brake lever
- Rear brake pedal
- Rear brake rod joint
- Side stand

Lubricate the following cables with motor oil:

- Clutch cable
- Throttle cable

Apply grease to the following points:

- Clutch cable upper end (inner cable)
- *Speedometer inner cable
- Throttle cable upper end (inner cable)

*Grease the lower part of the inner cable sparingly.

Bolts
Nuts
Fasteners

Tightness Inspection

- Check the tightness of the bolts and nuts listed here. Also, check to see that each cotter pin is in place and in good condition.

“NOTE”

○ For the engine fasteners, check the tightness of them when the engine is cold (at room temperature).

- ★ If there are loose fasteners, retorque them to the specified tightening sequence. (See “Torque and Locking Agent” section p. 1-17.) For each fastener first loosen it by ½ turn, then tighten it.
- ★ If cotter pins are damaged, replace them with new ones.
- Check the tightness of the following fasteners:

Wheel:

- Front axle nut
- Front axle clamp bolt
- Rear axle nut
- Rear axle nut cotter pin

Brake:

- Master cylinder clamp bolts
- Brake pedal bolt
- Brake rod joint cotter pin
- Caliper mounting bolts
- Torque link nuts

Suspension:

- Front fork clamp bolts
- Rear shock absorber bolts
- Swing arm pivot shaft(s)
- Uni-trak rocker arm pivot shaft
- Uni-trak tie-rod bolts

Steering:

- Handlebar clamp bolts
- Handlebar holder bolts
- Steering stem head bolt

Engine:

- Cylinder head nuts
- Exhaust pipe holder nuts
- Engine mounting nuts
- Engine mounting bracket bolts
- Muffler mounting nuts and bolt
- Shift pedal bolt

Others:

- Clutch lever holder bolt
- Center stand cotter pin
- Front footpeg mounting bolts
- Front footpeg bracket bolts
- Front footpeg cotter pins
- Rear footpeg cotter pins
- Rear footpeg mounting bolt nuts
- Side stand pivot bolt and nut

Brake Light Switch

Inspection

- Turn on the ignition switch.
- Check the operation of the rear brake light switch by depressing the brake pedal. The brake light should go on after about 15 mm of pedal travel.

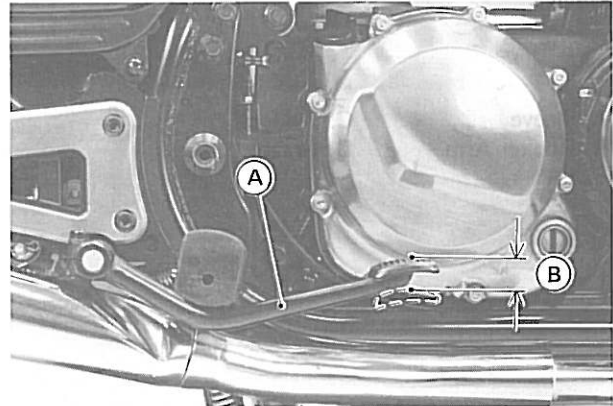

A. Rear Brake Pedal B. 15 mm

- ★ If it does not, adjust the brake light switch.

Adjustment

- Turn the adjusting nut to adjust the switch.

CAUTION

- To avoid damaging the electrical connections inside the switch, be sure that the switch body does not turn during adjustment.

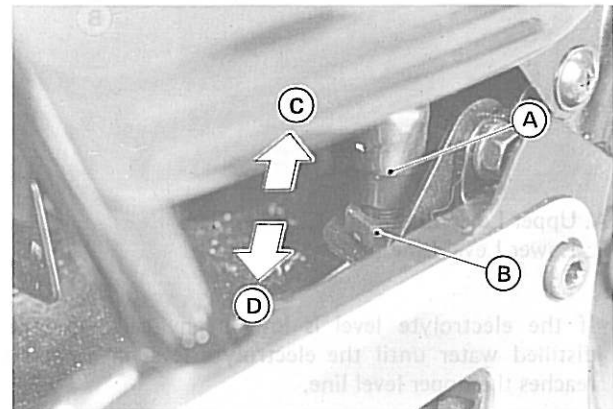

A. Rear Brake Light Switch C. Light sooner.
B. Adjusting Nut D. Lights later.

Non-scheduled Maintenance – Engine

Table of Contents

Service Data		p.1-12
Carburetors	Refer to Base Manual	p.376
Camshafts	Refer to Base Manual	p.162
Camshaft Chain, Tensioner	Refer to Base Manual	p.164
Cylinder Head, Valves		p.3-2
Valve Seat Repair	Refer to Base Manual	p.327
Cylinder Block, Pistons	Refer to Base Manual	p.171
Crankshaft, Connecting Rods	Refer to Base Manual	p.175
Clutch	Refer to Base Manual	p.179
Transmission	Refer to Base Manual	p.182
Engine Lubrication	Refer to Base Manual	p.188

**Cylinder Head
Valves**

Refer to p. 165 of the Base Manual, noting the following.

Measuring Valve Installed Height

- Install the valve in the cylinder head.
- Pushing up on the valve so that it seats firmly in the valve seat, measure the valve installed height with vernier calipers. The valve installed height is the distance from the bottom of the cylinder head lifter hole to the end of the valve stem.

CAUTION

- Do not grind the valve stem end to repair it or to permit additional valve clearance.
- If the valve end is ground, the shim may contact the spring retainer and/or split keepers during operation, allowing the keeper to loosen. Consequently, the valve may drop into the engine, causing serious damage.

Measuring Valve Installed Height

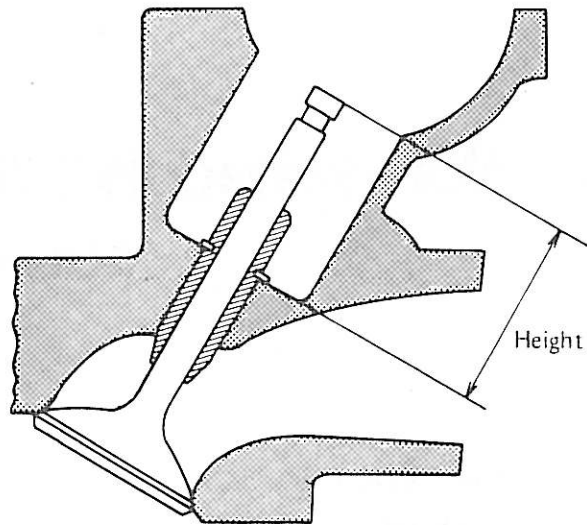

Valve Installed Height

Height (mm)		Probably Cause	Recommendation
Inlet	36.09 – 37.01	Normal/acceptable	● After assembling check and adjust valve clearance.
Exhaust	36.04 – 36.96		
Inlet	More than 37.01	Valve face or seat worn out, or ground excessively.	● Move valve to shallower cut seat. Remeasure.
Exhaust	More than 36.96		● Replace valve. Remeasure. ● Replace cylinder head. Remeasure.

Non-scheduled Maintenance – Chassis

Table of Contents

Service Data		p.1-16
Wheels	Refer to Base Manual	p.194
Wheel Balance	Refer to Base Manual	p.31
Tubeless Tires	Refer to Base Manual	p.288
Sprockets	Refer to Base Manual	p.197
Disc Brake		p.4-2
Drum Brake	Refer to Base Manual	p.292
Steering	Refer to Base Manual	p.382
Front Fork	Refer to Base Manual	p.294
Rear Shock Absorber	Refer to Base Manual	p.385
Uni-Trak	Refer to Base Manual	p.383

Disc Brake

Master Cylinder:

Visual Inspection

- Disassemble the master cylinder.
- Check that there are no scratches, rust or pitting on the inside of the master cylinder and on the outside of the piston.
- ★ If the master cylinder or piston shows any damage, replace the master cylinder and piston.
- Inspect the primary cup and O-ring on the piston.
- ★ If a cup or O-ring is worn, damaged, softened (rotted), or swollen, replace the piston assembly.
- ★ If fluid leakage is noted at the brake lever, the piston assembly should be replaced to renew the cup and O-ring.
- Check the dust cover for damage.
- ★ If it is damaged, replace it.
- Check that the relief and supply ports are not plugged.
- ★ If the small relief port becomes plugged, especially with a swollen or damaged primary cup, the brake pads will drag on the disc. Blow the ports clean with compressed air.
- Check the piston return spring for any damage.
- ★ If the spring is damaged, replace the piston assembly.

Master Cylinder

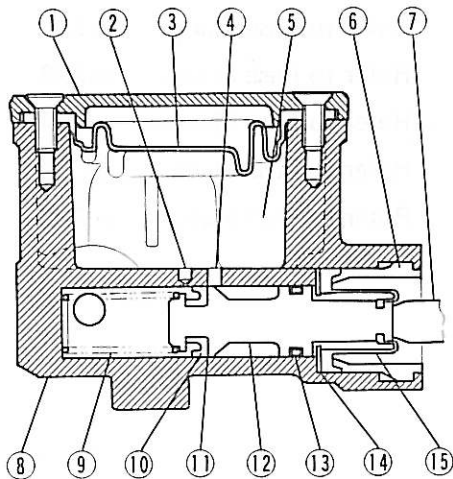

- | | |
|-------------------------|----------------------|
| 1. Reservoir Cap | 9. Return Spring |
| 2. Relief Port | 10. Primary Cup |
| 3. Diaphragm | 11. Non-return Valve |
| 4. Supply port | 12. Piston |
| 5. Reservoir | 13. O-Ring |
| 6. Liner | 14. Piston Stop |
| 7. Brake Lever | 15. Dust Cover |
| 8. Master Cylinder Body | |

Calipers:

Fluid Seal Damage

The fluid seal around the piston maintains the proper pad/disc clearance. If this seal is not satisfactory, pad wear will increase, and constant pad drag on the disc will raise brake and brake fluid temperature.

Replace the fluid seals under any of the following conditions: (a) fluid leakage around the pad; (b) brakes overheat; (c) there is a large difference in left and right

pad wear; (d) the seal is stuck to the piston. If the fluid seal is replaced, replace the dust seal as well. Also, replace all seals every other time the pads are changed.

Caliper

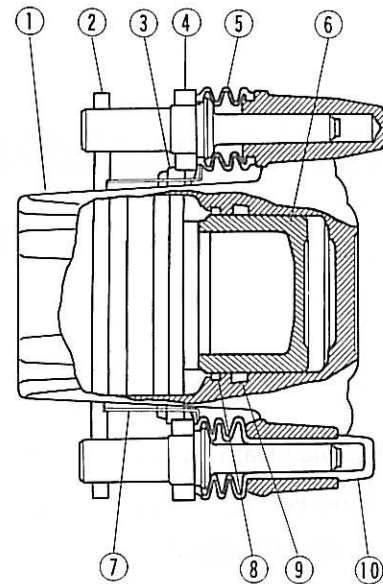

- | | |
|-------------------|-----------------------|
| 1. Caliper | 6. Piston |
| 2. Brake Pad | 7. Anti-Rattle Spring |
| 3. Brake Pad | 8. Dust Seal |
| 4. Caliper Holder | 9. Fluid Seal |
| 5. Dust Cover | 10. Friction Boot |

Dust Seal and Cover Damage

- Check that the dust seals and covers are not cracked, worn, swollen, or otherwise damaged.
- ★ If they shown any damage, replace them.

Piston Cylinder Damage

- Visually inspect the piston and cylinder surfaces.
- ★ Replace the cylinder and piston if they are badly scored or rusty.

Caliper Holder Shaft Wear

The caliper body must slide smoothly on the caliper holder shafts. If the body does not slide smoothly, one pad will wear more than the other, pad wear will increase, and constant drag on the disc will raise brake and brake fluid temperature.

- Check to see if the caliper holder shafts are not badly worn or stepped, or rubber friction boot are not damaged.
- ★ If the shafts or rubber friction boot are damaged, replace the rubber friction boot, and the caliper holder.

Brake Discs:

Disc Warp

Refer to p.203 of the Base Manual.

Disc Wear

Refer to p. 203 of the Base Manual.

Brake Hoses:

Brake Line Damage

Refer to p. 206 of the Base Manual.

Non-scheduled Maintenance – Electrical

Table of Contents

Precautions		p.5-2
Battery	Refer to Base Manual	p.214
Charging System	Refer to Base Manual	p.404
Ignition System	Refer to Base Manual	p.297
Electric Starter System	Refer to Base Manual	p.302
Headlight	Refer to Base Manual	p.230
Turn Signals	Refer to Base Manual	p.234
Tail/Brake Light	Refer to Base Manual	p.374
Fuel Gauge	Refer to Base Manual	p.334
Speedometer	Refer to Base Manual	p.236
Tachometer	Refer to Base Manual	p.385

Precautions

There are numbers of important precautions that are musts when servicing electrical systems. Though cautions that apply to the indications are listed below, failure to observe these rules can result in serious system damage. Learn and observe all the rules below.

- (a) Do not reverse the battery lead connections. This will burn out the diodes in the electrical parts.
- (b) Always check battery condition before condemning other parts of an electrical system. A fully charged battery is a must for conducting accurate electrical system tests.
- (c) The electrical parts should never be struck sharply, as with a hammer, or allowed to fall on a hard surface. Such a shock to the parts can damage them.
- (d) To prevent damage to electrical parts, unless otherwise there is instruction during a test, do not disconnect the battery leads or any other electrical connections when the ignition switch is on, or during the engine is running.
- (e) Because of the large amount of current, never keep the starter switch pushed when the starter motor will not turn over, or the current may burn out the starter motor windings.
- (f) Do not use a meter illumination bulb rated for other than voltage or watage specified in the wiring diagram, as the meter or gauge panel could be warped by excessive heat radiated from the bulb.
- (g) Take care not to short the leads that are directly connected to the battery positive (+) terminal to the chassis ground.
- (h) Troubles may involve one or in some cases all items. Never replace a defective part without determining what CAUSED the failure. If the failure was brought on by some other item or items, they too must be repaired or replaced, or the new replacement will soon fail again.
- (i) Make sure all connectors in the circuit are clean and tight, and examine wires for signs of burning, fraying, etc. Poor wires and bad connections will affect electrical system operation.
- (j) Electrical Connectors

Female Connectors

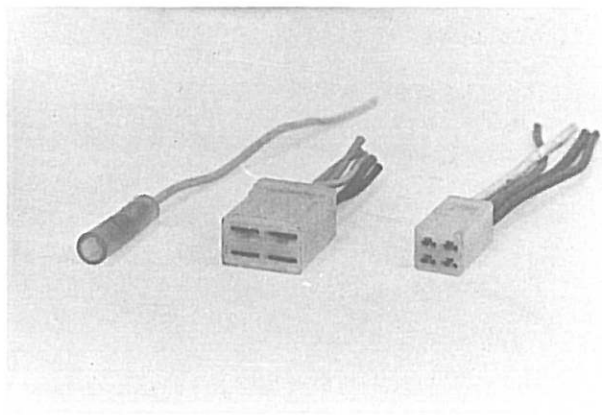

Male Connectors

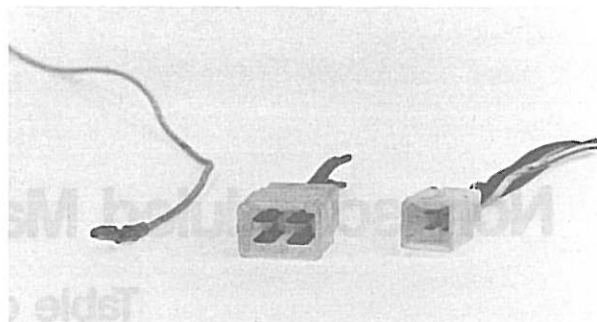

(k) Color Codes:

BK	Black
BL	Blue
BR	Brown
CH	Chocolate
DG	Dark green
G	Green
GY	Gray
LB	Light blue
LG	Light green
O	Orange
P	Pink
R	Red
W	White
Y	Yellow

- (l) Measure coil and winding resistance when the part is cold (at room temperature)

Disassembly – Engine

Table of Contents

Accessories

Fuel Tank	Refer to Base Manual	p.47
Fuel Tap	Refer to Base Manual	p.268
Fuel Level Sender	Refer to Base Manual	p.322
Ignition Coils	Refer to Base Manual	p.57
Carburetors	Refer to Base Manual	p.361
Air Cleaner Elements	Refer to Base Manual	p.361
Mufflers	Refer to Base Manual	p.269

Top End

Cam Chain Tensioner	Refer to Base Manual	p.58
Cam Chain Guide (Upper)	Refer to Base Manual	p.66
Camshaft	Refer to Base Manual	p.365
Camshaft Sprocket	Refer to Base Manual	p.271
Cylinder Head	Refer to Base Manual	p.61
Cylinder Block	Refer to Base Manual	p.64
Cam Chain Guide	Refer to Base Manual	p.66
Pistons	Refer to Base Manual	p.67
Piston Rings	Refer to Base Manual	p.67
Oil Separator (Breather) Cover	Refer to Base Manual	p.68
Carburetor Holder	Refer to Base Manual	p.272

Left Side

Shift Pedal Linkage	Refer to Base Manual	p.322
Clutch Release	Refer to Base Manual	p.319
Engine Sprocket	Refer to Base Manual	p.71
Neutral Switch	Refer to Base Manual	p.73
External Shift Mechanism	Refer to Base Manual	p.71
Alternator Rotor	Refer to Base Manual	p.76
Alternator Stator	Refer to Base Manual	p.75
Starter Motor	Refer to Base Manual	p.272

(Continued on next page.)

Right Side

Pickup Coil Assembly	Refer to Base Manual	p.273
Timing Advancer	Refer to Base Manual	p.274
Clutch	Refer to Base Manual	p.78

Bottom End

Oil Pressure Switch	Refer to Base Manual	p.81
Oil Filter	Refer to Base Manual	p.81
Bypass Valve	Refer to Base Manual	p.81
Oil Pressure Relief Valve	Refer to Base Manual	p.81
Oil Pump	Refer to Base Manual	p.83
Secondary Shaft	Refer to Base Manual	p.84
Secondary Sprocket	Refer to Base Manual	p.84
Starter Motor Clutch	Refer to Base Manual	p.84
Starter Motor Idle Gear	Refer to Base Manual	p.87

Engine Removal

Engine Unit	Refer to Base Manual	p.365
-------------------	----------------------	-------

Engine Split

Crankcase Split	Refer to Base Manual	p.96
Transmission	Refer to Base Manual	p.104
Shift Mechanism	Refer to Base Manual	p.104
Crankshaft	Refer to Base Manual	p.109
Primary Chain	Refer to Base Manual	p.109
Camshaft Chain	Refer to Base Manual	p.109
Connecting Rods	Refer to Base Manual	p.110

Disassembly – Chassis

Table of Contents

Wheels

Front Wheel	Refer to Base Manual	p.275
Speedometer Gear	Refer to Base Manual	p.116
Rear Wheel	Refer to Base Manual	p.278
Wheel Coupling, Rear Sprocket	Refer to Base Manual	p.125
Wheel Bearing	Refer to Base Manual	p.126
Tires (Tubeless)	Refer to Base Manual	p.281

Brakes

Pads		p.7-2
Discs	Refer to Base Manual	p.276
Brake Hoses	Refer to Base Manual	p.123
Calipers		p.7-2
Front Master Cylinder	Refer to Base Manual	p.121
Front Brake Light Switch	Refer to Base Manual	p.366
Drum Brake	Refer to Base Manual	p.279

Electrical Equipment

Headlight Bulb	Refer to Base Manual	p.325
Handlebar Switch Housing	Refer to Base Manual	p.367
Electrical Panel	Refer to Base Manual	p.372

Steering

Handlebars, Holders	Refer to Base Manual	p.367
Steering Stem	Refer to Base Manual	p.369
Stem Bearings	Refer to Base Manual	p.369

Suspension and Drive Train

Front Fork	Refer to Base Manual	p.368
Uni-Trak	Refer to Base Manual	p.370
Drive Chain	Refer to Base Manual	p.370

Pads, Caliper

Refer to p. 276 – 278 of the Base Manual, noting the following.

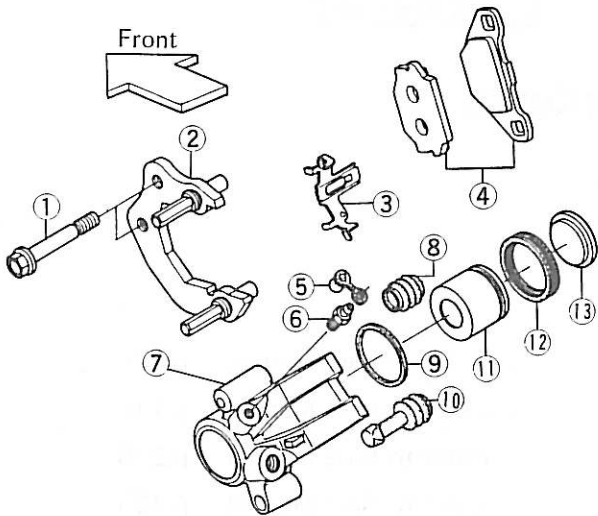
Front Caliper

- | | |
|-----------------------|-----------------|
| 1. Mounting bolt | 8. Dust cover |
| 2. Caliper holder | 9. Fluid seal |
| 3. Anti-rattle spring | 10. Dust cover |
| 4. Pads | 11. Piston |
| 5. Rubber cap | 12. Dust cover |
| 6. Bleed valve | 13. Piston head |
| 7. Caliper | |

Tightening Torque:

Caliper mounting bolt ① 29 N-m (3.0 kg-m, 22 ft-lb)

Bleed valve ⑥ 7.8 N-m (0.80 kg-m, 69 in-lb)

Appendix

Table of Contents

Additional Considerations for Racing	Refer to Base Manual	p.242
Troubleshooting Guide	Refer to Base Manual	p.237
Unit Conversion Table		p.8-2

Unit Conversion Table

Prefixes for Units:

Prefix	Symbol	Power
mega	M	x 1,000,000
kilo	k	x 1,000
centi	c	x 0.01
milli	m	x 0.001
micro	μ	x 0.000001

Units of Length:

km	x	0.6214	=	mile
m	x	3.281	=	ft
mm	x	0.03937	=	in

Units of Volume:

L	x	0.2642	=	gal (US)
L	x	0.2200	=	gal (imp)
L	x	1.057	=	qt (US)
L	x	0.8799	=	qt (imp)
L	x	2.113	=	pint (US)
L	x	1.816	=	pint (imp)
mL	x	0.03381	=	oz (US)
mL	x	0.02816	=	oz (imp)
mL	x	0.06102	=	cu in

Units of Force:

N	x	0.1020	=	kg
N	x	0.2248	=	lb
kg	x	9.807	=	N
kg	x	2.205	=	lb

Unit of Mass:

kg	x	2.205	=	lb
g	x	0.03527	=	oz

Units of Torque:

N-m	x	0.1020	=	kg-m
N-m	x	0.7376	=	ft-lb
N-m	x	8.851	=	in-lb
kg-m	x	9.807	=	N-m
kg-m	x	7.233	=	ft-lb
kg-m	x	86.80	=	in-lb

Units of Pressure:

kPa	x	0.01020	=	kg/cm ²
kPa	x	0.1450	=	psi
kPa	x	0.7501	=	cmHg
kg/cm ²	x	98.07	=	kPa
kg/cm ²	x	14.22	=	psi
cmHg	x	1.333	=	kPa

Units of Speed:

km/h	x	0.6214	=	mph
------	---	--------	---	-----

Units of Power:

kW	x	1.360	=	PS
kW	x	1.341	=	HP
PS	x	0.7355	=	kW
PS	x	0.9863	=	HP

Units of Temperature:

$$\frac{9 (°C + 40)}{5} - 40 = °F$$

$$\frac{5 (°F + 40)}{9} - 40 = °C$$

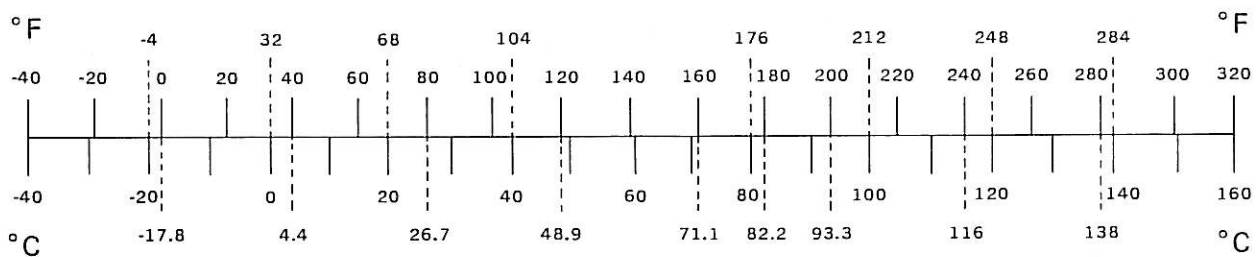

Supplement — 1984 Model

This chapter, "Supplement—1984 Model", is designed to be used in conjunction with the front part of this manual (up to the end of the chapter 8). The maintenance and repair procedures described in this chapter are only those that are unique to the 1984 model. Complete and proper servicing of the 1984 model therefore requires mechanics to read both this chapter and the front part of this manual (up to the end of the chapter 8).

"NOTE"

- *The service procedures for the 1984 model ZR400B and ZX550A are newly included in this section. Unless otherwise noted, refer to the description for the following 1983 models.*
 ZR400-A1 for ZR400-B1
 ZR550-A1 for ZX550-A1
- *When handling the Evaporative Emission Control System for the California vehicle, keep the instructions in the Disassembly section.*
- *Refer to the Base Manual for the items paged p. xxx.*

Table of Contents

General Information		Charging System (ZX550)	9-25
Model Identification	9-2	Ignition System (ZX550)	9-25
Specifications (ZR400B)	9-3	Electric Starter System (ZX550)	9-29
Specifications (ZX550)	9-5	Headlight Reserve Lighting System (US and Canada)	p.330
Setting Before Ride (ZX550)	9-7	Turn Signal Circuit	9-30
High Altitude Performance Adjustment Information (US Model)	9-8	Hazard Warning Circuit (US and Canada)	p.373
Service Data	9-9	LCD Fuel Gauge and Warner Unit (ZX550)	9-31
Torque and Locking Agent	9-14	Tacho/Voltmeter (ZX550)	p.385
ZX550-A1 Wiring Diagram (US and Canada)	9-15	Disassembly	
ZX550-A1 Wiring Diagram (Other than US and Canada)	9-16	Evaporative Emission Control System (US California Vehicle only)	9-34
Scheduled Maintenance		Oil Cooler (ZX550)	p.323
Periodic Maintenance Chart (ZX550)	9-17	Vacuum Switch Valve (US Model)	p.269
Air Suction Valves (US Model)	9-18	Air Suction Valves (US Model)	p.270
Air Cleaner Element (ZX550)	9-18	Camshafts (ZX550)	9-35
Evaporative Emission Control System (US California Vehicle only)	9-18	Camshaft Sprockets (ZX550)	9-35
Clutch (ZX550)	9-18	Cylinder Block	9-35
Drive Chain (ZX550)	9-19	Clutch Release (ZX550)	9-35
Brakes (ZX550)	9-20	Clutch (ZX550)	9-35
Front Fork (ZX550)	9-21	Crankcase Split	9-35
Swing Arm (ZX550)	9-21	Bearing Insert Selection	9-37
Uni-Trak (ZX550)	9-21	Engine Removal (ZX550)	9-40
Non-scheduled Maintenance		Rear Wheel (ZX550)	p.366
Evaporative Emission Control System (US California Vehicle only)	9-22	Brakes (ZX550)	9-41
Kawasaki Clean Air System (US Model)	p.286	Front Fork (ZX550)	9-42
Wheel Balance (ZX550)	9-22	Swing Arm (ZX550)	9-43
Front Fork (ZX550)	9-24	Uni-Trak Links (ZX550)	9-43
		Rear Shock Absorber (ZX550)	9-43

General Information

.....
Model Identification
.....

ZR400-B1:



ZR550-A2:

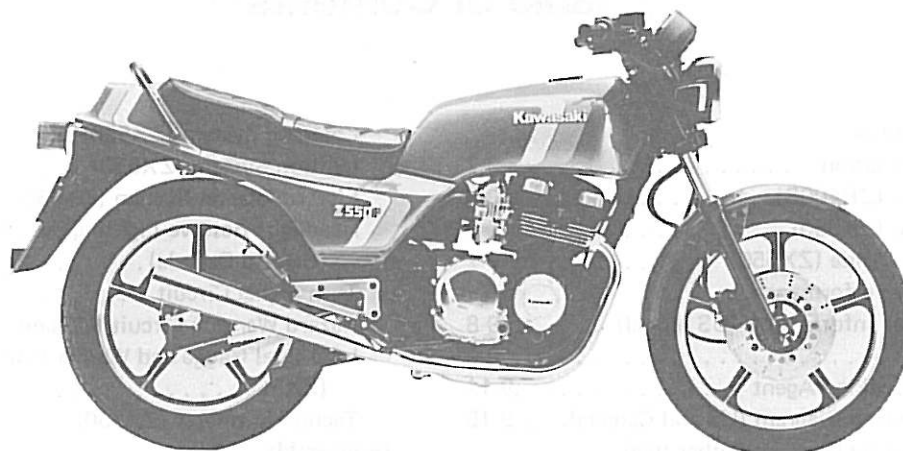

ZX550-A1:

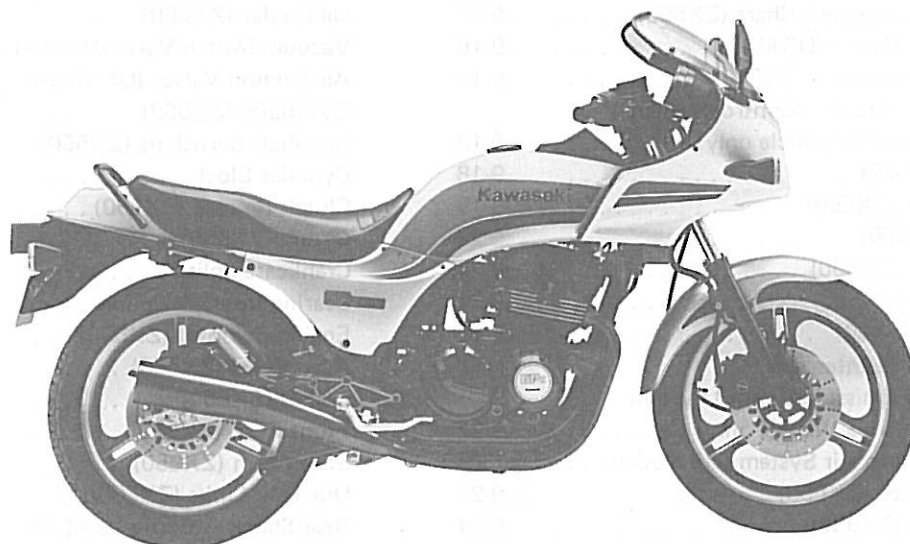

Specifications (ZR400B)

Items	ZR400-B1
Dimensions: Overall length Overall width Overall height Wheelbase Road clearance Seat height Dry weight Curb weight: Front Rear Fuel tank capacity	2,235 mm 750 mm 1,105 mm 1,450 mm 160 mm 795 mm 1,770 N (180 kg) 922 N (94 kg) 1,010 N (103 kg) 18.5 L
Performance: Climbing ability Braking distance Minimum turning radius	30° 12 m from 50 km/h 2.5 m
Engine: Type Cooling system Bore and stroke Displacement Compression ratio Maximum horsepower Maximum torque Carburetion system Starting system Ignition system Timing advance Ignition timing Spark plug Cylinder numbering method Firing order Valve timing: Inlet Open Close Duration Exhaust Open Close Duration Lubrication system Engine Oil: Grade Viscosity Capacity	4-stroke, DOHC, 4-cylinder Air cooled 55.0 x 42.0 mm 399 mL 9.7 36 kW (49 PS) @10,500 r/min (rpm) (W) 19.9 kW (27 PS) @9,000 r/min (rpm) 34 N-m (3.5 kg-m, 25 ft-lb) @8,500 r/min (rpm) (W) 25 N-m (2.5 kg-m, 18.0 ft-lb) @7,000 r/min (rpm) Carburetors, TK K26V x 4 Electric starter Battery and coil (transistorized) Mechanically advanced From 15° BTDC @1,200 r/min (rpm) to 40° BTDC @3,200 r/min (rpm) NGK DPR9EA-9 or ND X27EPR-U9 (I) NGK DP9EA-9 or ND X27EP-U9 Left to right, 1-2-3-4 1-2-4-3 36° BTDC (W) 33° BTDC 44° ABDC (W) 41° ABDC 260° (W) 254° 54° BBDC (W) 51° BBDC 26° ATDC (W) 23° ATDC 260° (W) 254° Forced lubrication (wet sump) SE class SAE 10W40, 10W50, 20W40, or 20W50 3.0 L

(Continued on next page.)

9-4 SUPPLEMENT—1984 MODEL

Items	ZR400-B1
Drive Train:	
Primary reduction system:	
Type	Gear and chain
Reduction ratio	3.277 (27/23 x 67/24)
Clutch type	Wet multi disc
Transmission: Type	6-speed, constant mesh, return shift
Gear ratios:	
1st	2.571 (36/14)
2nd	1.777 (32/18)
3rd	1.380 (29/21)
4th	1.125 (27/24)
5th	0.961 (25/26)
6th	0.851 (23/27)
Final drive system: Type	Chain drive
Reduction ratio	2.500 (40/16)
Overall drive ratio	6.979 @Top gear
Frame:	
Type	Tubular, double cradle
Castor (rake angle)	27°
Trail	105 mm
Front tire: Type	Tubeless
Size	90/90-19 52S
Rear tire: Type	Tubeless
Size	110/90-18 61S
Front suspension: Type	Telescopic fork (pneumatic)
Wheel travel	175 mm
Rear suspension: Type	Swing arm (uni-trak)
Wheel travel	140 mm
Brake type: Front	Dual disc
Rear	Drum
Electrical Equipment:	
Battery	12 V 10 AH
Headlight: Type	Semi-sealed beam
Bulb	12 V 60/55 W (quartz-halogen)
Tail/brake light	12 V 5/21 W x 2
Alternator: Type	Three-phase AC
Rated output	18.5 A @10,000 r/min (rpm), 14 V
Voltage regulator: Type	Short-circuit

Specifications subject to change without notice, and may not apply to every country.

Ⓘ : Italian Model Ⓜ : West German Model

Specifications (ZX550)

Items	ZX550-A1
Dimensions: Overall length Overall width Overall height Wheelbase Road clearance Seat height Dry weight Curb weight: Front Rear Fuel tank capacity	2,155 mm (A) (E) 2,205 mm 720 mm 1,245 mm 1,445 mm 160 mm 780 mm 1,870 N (191 kg) (C) 1,880 N (191.5 kg) 1,010 N (103 kg) (C) 1,020 N (103.5 kg) 1,040 N (106 kg) 18.0 L
Performance: Climbing ability Braking distance Minimum turning radius	30° 12 m from 50 km/h 2.5 m
Engine: Type Cooling system Bore and stroke Displacement Compression ratio Maximum horsepower Maximum torque Carburetion system Starting system Ignition system Timing advance Ignition timing Spark plug Cylinder numbering method Firing order Valve timing: Inlet Open Close Duration Exhaust Open Close Duration Lubrication system Engine Oil: Grade Viscosity Capacity	4-stroke, DOHC, 4-cylinder Air cooled 58.0 x 52.4 mm 553 mL 10.0 47.8 kW (65 PS) @10,500 r/min (rpm) (S) 37.5 kW (51 PS) @8,700 r/min (rpm) 48 N-m (4.9 kg-m, 35 ft-lb) @8,500 r/min (rpm) (S) 42 N-m (4.3 kg-m, 31 ft-lb) @8,000 r/min (rpm) Carburetors, TK K27V x 4 Electric starter Battery and coil (transistorized) Electronically advanced From 12.5° BTDC @1,050 r/min (rpm) to 40° BTDC @10,000 r/min (rpm) (U) From 12.5° BTDC @1,200 r/min (rpm) to 40° BTDC @10,000 r/min (rpm) NGK DP9EA-9 or ND X27EP-U9 (CE) NGK DPR9EA-9 or ND X27EPR-U9 Left to right, 1-2-3-4 1-2-4-3 46° BTDC 54° ABDC 280° 64° BBDC 36° ATDC 280° Forced lubrication (wet sump with cooler) SE or SF class SAE 10W40, 10W50, 20W40, or 20W50 3.0 L

(Continued on next page.)

9-6 SUPPLEMENT—1984 MODEL

Items	ZX550-A1
Drive Train:	
Primary reduction system:	
Type	Gear and chain
Reduction ratio	2.934 (27/23 x 65/26)
Clutch type	Wet multi disc
Transmission: Type	6-speed, constant mesh, return shift
Gear ratios: 1st	2.571 (36/14)
2nd	1.777 (32/18)
3rd	1.380 (29/21)
4th	1.125 (27/24)
5th	0.961 (25/26)
6th	0.851 (23/27)
Final drive system: Type	Chain drive
Reduction ratio	2.375 (38/16)
Overall drive ratio	5.937 @Top gear
Frame:	
Type	Tubular, double cradle
Castor (rake angle)	26°
Trail	95 mm
Front tire: Type	Tubeless
Size	100/90-18 56H
Rear tire: Type	Tubeless
Size	120/80-18 62H
Front suspension: Type	Telescopic fork (pneumatic)
Wheel travel	160 mm
Rear suspension: Type	Swing arm (uni-trak)
Wheel travel	130 mm
Brake type: Front	Dual disc
Rear	Single disc
Electrical Equipment:	
Battery	12 V 12 AH
Headlight: Type	Semi-sealed beam
Bulb	12 V 60/55 W (quartz-halogen)
Tail/brake light	12 V 8/27 W x 2 (A)(E) 12 V 5/21 W x 2
Alternator: Type	Three-phase AC
Rated output	18.5 A @10,000 r/min (rpm), 14 V
Voltage regulator: Type	Short-circuit

Specifications subject to change without notice, and may not apply to every country.

(A) : Australian Model

(C) : US California Model

(E) : European Model

(S) : Swiss Model

(U) : US Model

(CE) : Canadian Model and European Model except Italian Model

Setting Before Ride (ZX550)

Front Fork:

Refer to p.1-9 – p. 1-10, noting the following.

Anti-dive Adjustment

The anti-dive unit on each fork leg can be adjusted for different road and loading conditions by changing the adjuster position, low to high.

- Remove the dust cover from the bottom of each anti-dive unit.
- Turn the anti-dive adjuster until it comes to the desired position.
- Check to see that both adjusters are turned to the same relative position.

WARNING

- If both anti-dive adjusters are not adjusted equally, handling may be impaired and a hazardous condition may result.
- Install the dust cover.

Anti-dive Adjustment

Adjuster Position	Lowest	Middle	Highest
Anti-dive	Weak	Moderate	Strong

"NOTE"

- The recommended setting position is the lowest position for one rider with no accessories.

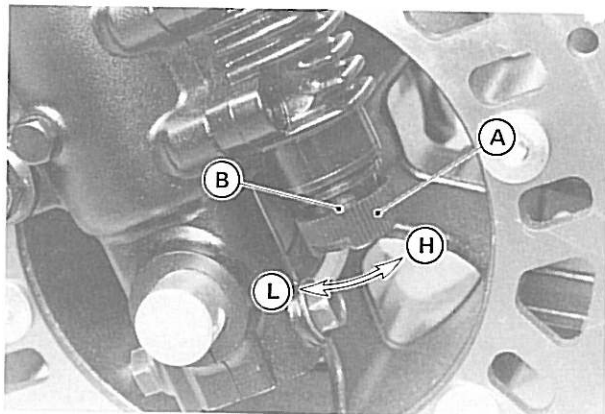

A. Anti-dive Adjuster B. Middle Line

Rear Shock Absorber:

The rear shock absorber can be adjusted by changing the spring force and damping force to suit various riding and loading conditions.

Spring Force Adjustment

- Set the motorcycle up on its center stand.
- Remove the right side cover.
- Turn the remoto adjuster to the desired position.

Spring Force

Adjuster Position	Spring Force	Setting	Load	Road
L ↑	Stronger ↓	Soft ↑	Light ↑	Good ↑
M				
H ↓		Hard ↓	Heavy ↓	Bad ↓

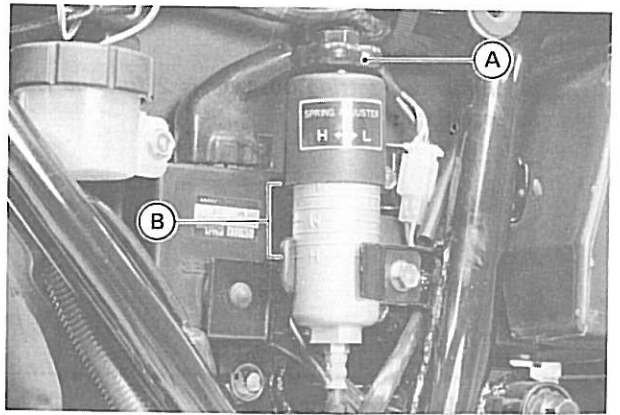

A. Remoto Adjuster B. Adjuster Range

"NOTE"

- The recommended setting position is the L position for one rider with no accessories.

Damping Force Adjustment

- Turn the damper adjuster to the desired position so that the number on the adjuster aligns with the arrow.

"NOTE"

- The damping force can be left soft for average riding. But it should be adjusted harder for high speed riding, or riding with a passenger. If the damper setting feels too soft or too stiff, adjust it in accordance with the following table:

Damping Force

Setting Position	Damping Force	Setting	Load	Road	Speed
1	Stronger ↓	Soft ↑	Light ↑	Good ↑	Low ↑
2					
3					
4		Hard ↓	Heavy ↓	Bad ↓	High ↓

9-8 SUPPLEMENT—1984 MODEL

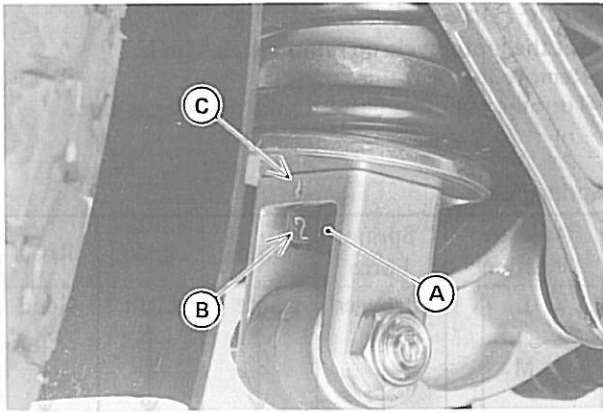

A. Adjuster
B. Number

C. Arrow

"NOTE"

○The recommended setting position is 2 for one rider with no accessories.

High Altitude Performance Adjustment Information (US Model)

To improve the EMISSION CONTROL PERFORMANCE of vehicles operated above 4,000 feet an Environmental Protection Agency (EPA) approved modification may be required for some models. However, any kind of modification is not necessary for the 1984 model ZX550-A1.

Service Data

Refer to p. 1-12 — p. 1-16, noting the following.

Item	Standard	Service Limit	See Page
Idle speed ZR400B ZR/ZX550 ZX550US	1,200 ±50 r/min (rpm) 1,050 ±50 r/min (rpm) 1,200 ±50 r/min (rpm)		p. 2-8
Carburetors:	ZR400B	ZR550	ZX550
Make, Type	TK, K26V	TK, K26V	TK, K27V
Main jet	#104, (W) #102	#100	#114
Main air jet	#100	#60	φ1.0
Jet needle	4A01	4A00	4A10
Jet needle clip position	Fourth groove from top	Second groove from top	Non-adjustable
Pilot jet	#32	#32	#34
Pilot air jet	#140	#140	φ1.25
Pilot screw	1 ⁷ / ₈ turns out (W) 2 turns out	2 ¹ / ₂ turns out (W) 2 turns out	2 ¹ / ₂ turns out (S)(U) Non-adjustable
Service fuel level	7 ±1 mm	7 ±1 mm	7 ±1 mm
Float height	27 mm	27 mm	27 mm
Camshafts:			
Cam height ZR400B/ZX550	36.246 — 36.354 mm		36.15 mm
ZR400B West German Model	35.746 — 35.854 mm		35.65 mm
ZR550	35.546 — 35.654 mm		35.45 mm
Cylinder Head:			
Combustion chamber volume ZR400B/ZX550	14.6 — 15.4 mL		p. 165
ZR550	15.2 — 16.0 mL		p. 165
Cylinder Block, Pistons:			
Cylinder compression	Less than 98 kPa (1 kg/cm ² , 14 psi) difference between any two cylinders, and		p. 171
ZR400B	755 — 1,180 kPa (7.7 — 12.0 kg/cm ² , 109 — 171 psi)		
ZR550	885 — 1,360 kPa (9.0 — 13.9 kg/cm ² , 128 — 198 psi)		
ZX550	825 — 1,280 kPa (8.4 — 13.0 kg/cm ² , 119 — 185 psi)		

(S) : Swiss Model

(U) : US Model

(W) : West German Model

(Continued on next page.)

9-10 SUPPLEMENT—1984 MODEL

Item	Standard	Service Limit	See Page
Cylinder inside diameter ZR400B ZR550/ZX550	55.000 – 55.012 mm, and less than 0.01 mm difference between any two measurements 58.000 – 58.012 mm, and less than 0.01 mm difference between any two measurements	55.10 mm, or 0.05 mm difference between any two measurements 58.10 mm, or 0.05 mm difference between any two measurements	p. 172
Piston diameter ZR400B ZR550/ZX550	54.965 – 54.980 mm 57.965 – 57.980 mm	54.83 mm 57.83 mm	p. 172
Piston ring/groove clearance ZR400B (Top and second) ZR550 Top Second ZX550 (Top and Second)	0.03 – 0.07 mm 0.020 – 0.055 mm 0.040 – 0.075 mm 0.020 – 0.055 mm	0.17 mm 0.16 mm 0.18 mm 0.16 mm	p. 173
Piston ring thickness ZR400B Top Second ZR550/ZX550 (Top and Second)	0.97 – 0.99 mm 1.17 – 1.19 mm 1.175 – 1.190 mm	0.90 mm 1.10 mm 1.10 mm	p. 173
Piston ring groove width ZR400B Top Second Oil ZR550 Top Second Oil ZX550 Top and Second Oil	1.02 – 1.04 mm 1.22 – 1.24 mm 2.51 – 2.53 mm 1.21 – 1.23 mm 1.23 – 1.25 mm 2.51 – 2.53 mm 1.21 – 1.23 mm 2.51 – 2.53 mm	1.12 mm 1.32 mm 2.61 mm 1.31 mm 1.33 mm 2.61 mm 1.31 mm 2.61 mm	p. 173
Clean Air System: Vacuum switch valve operation Open → Close Close → Open	50 – 64 kPa (38 – 48 cm Hg) of vacuum 49 kPa (37 cm Hg) of vacuum		p. 287

Item	Standard	Service Limit	See Page																	
Wheels:																				
Tire payload			p. 194																	
ZR400B	1,470 N (150 kg)																			
ZR550	1,620 N (165 kg)																			
ZX550	1,820 N (185 kg)																			
Standard tires:																				
ZR400B		ZR550																		
<table border="1"> <thead> <tr> <th>Front</th> <th>Rear</th> </tr> </thead> <tbody> <tr> <td>90/90-19 52S Dunlop F14 Tubeless</td> <td>110/90-18 61S Dunlop K130A Tubeless</td> </tr> </tbody> </table>	Front	Rear	90/90-19 52S Dunlop F14 Tubeless	110/90-18 61S Dunlop K130A Tubeless	<table border="1"> <thead> <tr> <th>Front</th> <th>Rear</th> </tr> </thead> <tbody> <tr> <td>3.25H19 4PR Dunlop F8 MarkII A Tubeless</td> <td>4.00H18 4PR Dunlop K427A Tubeless</td> </tr> </tbody> </table>		Front	Rear	3.25H19 4PR Dunlop F8 MarkII A Tubeless	4.00H18 4PR Dunlop K427A Tubeless										
Front	Rear																			
90/90-19 52S Dunlop F14 Tubeless	110/90-18 61S Dunlop K130A Tubeless																			
Front	Rear																			
3.25H19 4PR Dunlop F8 MarkII A Tubeless	4.00H18 4PR Dunlop K427A Tubeless																			
ZX550																				
<table border="1"> <thead> <tr> <th>Front</th> <th>Rear</th> </tr> </thead> <tbody> <tr> <td>100/90-18 56H Dunlop Gold Seal F11 © or Bridgestone Mag. Mopus L303 Tubeless</td> <td>120/80-18 62H Dunlop K727 © or Bridgestone Mag. Mopus G508 Tubeless</td> </tr> </tbody> </table>		Front	Rear	100/90-18 56H Dunlop Gold Seal F11 © or Bridgestone Mag. Mopus L303 Tubeless	120/80-18 62H Dunlop K727 © or Bridgestone Mag. Mopus G508 Tubeless															
Front	Rear																			
100/90-18 56H Dunlop Gold Seal F11 © or Bridgestone Mag. Mopus L303 Tubeless	120/80-18 62H Dunlop K727 © or Bridgestone Mag. Mopus G508 Tubeless																			
© : Other than US and Canada only																				
Air pressure:																				
p. 1-9																				
ZR400B																				
<table border="1"> <thead> <tr> <th>Front</th> <th colspan="2">Rear</th> </tr> </thead> <tbody> <tr> <td>196 kPa (2.00 kg/cm², 28 psi)</td> <td>Up to 956 N (97.5 kg) load</td> <td>221 kPa (2.25 kg/cm², 32 psi)</td> </tr> <tr> <td></td> <td>956 – 1,470 N (97.5 – 150 kg) load</td> <td>245 kPa (2.50 kg/cm², 36 psi)</td> </tr> </tbody> </table>	Front	Rear		196 kPa (2.00 kg/cm ² , 28 psi)	Up to 956 N (97.5 kg) load	221 kPa (2.25 kg/cm ² , 32 psi)		956 – 1,470 N (97.5 – 150 kg) load	245 kPa (2.50 kg/cm ² , 36 psi)											
Front	Rear																			
196 kPa (2.00 kg/cm ² , 28 psi)	Up to 956 N (97.5 kg) load	221 kPa (2.25 kg/cm ² , 32 psi)																		
	956 – 1,470 N (97.5 – 150 kg) load	245 kPa (2.50 kg/cm ² , 36 psi)																		
ZX550 US, Canada		ZX550 Other than US, Canada																		
<table border="1"> <thead> <tr> <th>Front</th> <th colspan="2">Rear</th> </tr> </thead> <tbody> <tr> <td>196 kPa (2.00 kg/cm², 28 psi)</td> <td>Up to 956 N (97.5 kg) load</td> <td>221 kPa (2.25 kg/cm², 32 psi)</td> </tr> <tr> <td></td> <td>956 – 1,820 N (97.5 – 186 kg) load</td> <td>245 kPa (2.50 kg/cm², 36 psi)</td> </tr> </tbody> </table>	Front	Rear		196 kPa (2.00 kg/cm ² , 28 psi)	Up to 956 N (97.5 kg) load	221 kPa (2.25 kg/cm ² , 32 psi)		956 – 1,820 N (97.5 – 186 kg) load	245 kPa (2.50 kg/cm ² , 36 psi)	<table border="1"> <thead> <tr> <th>Front</th> <th colspan="2">Rear</th> </tr> </thead> <tbody> <tr> <td>196 kPa (2.00 kg/cm², 28 psi)</td> <td>Up to 1,470 N (150 kg) load</td> <td>221 kPa (2.25 kg/cm², 32 psi)</td> </tr> <tr> <td></td> <td>1,470 – 1,820 N (150 – 186 kg) load</td> <td>245 kPa (2.50 kg/cm², 36 psi)</td> </tr> </tbody> </table>		Front	Rear		196 kPa (2.00 kg/cm ² , 28 psi)	Up to 1,470 N (150 kg) load	221 kPa (2.25 kg/cm ² , 32 psi)		1,470 – 1,820 N (150 – 186 kg) load	245 kPa (2.50 kg/cm ² , 36 psi)
Front	Rear																			
196 kPa (2.00 kg/cm ² , 28 psi)	Up to 956 N (97.5 kg) load	221 kPa (2.25 kg/cm ² , 32 psi)																		
	956 – 1,820 N (97.5 – 186 kg) load	245 kPa (2.50 kg/cm ² , 36 psi)																		
Front	Rear																			
196 kPa (2.00 kg/cm ² , 28 psi)	Up to 1,470 N (150 kg) load	221 kPa (2.25 kg/cm ² , 32 psi)																		
	1,470 – 1,820 N (150 – 186 kg) load	245 kPa (2.50 kg/cm ² , 36 psi)																		
Tire tread depth																				
Front	ZR400B	3.4 mm	1 mm																	
	ZR550	3.5 mm	1 mm																	
	ZX550	4.4 mm (Dunlop), 4.3 mm (Bridgestone)	1 mm																	
p. 2-21																				

(Continued on next page.)

9-12 SUPPLEMENT—1984 MODEL

Item	Standard	Service Limit	See Page
Rear ZR400B ZR550 ZX550	6.9 mm 7.3 mm 7.0 mm (Dunlop), 8.6 mm (Bridgestone)	2 mm 2 mm Under 110 km/h 2 mm Over 110 km/h 3 mm	
Drive Train: Drive chain slack ZR400B/550 ZX550 Drive chain 20-link length Front sprocket diameter Rear sprocket diameter ZR400B ZR550/ZX550	30 – 35 mm 35 – 40 mm 317.5 – 318.4 mm 71.01 – 71.21 mm 192.22 – 192.72 mm 182.13 – 182.63 mm	30 – 40 mm 35 – 45 mm 323 mm 70.3 mm 191.9 mm 181.8 mm	p.2-13 p. 2-14 p. 197 p. 197
Brakes: Pad lining thickness ZR400B/550 ZX550 Disc thickness Front ZR400B/550 ZX550 Rear ZX550 Brake pedal position ZR400B/550 ZX550	4.5 mm 4.85 mm 3.8 – 4.1 mm 4.8 – 5.1 mm 5.8 – 6.1 mm 0 – 30 mm 25 – 30 mm below from top of footpeg	1 mm 1 mm 3.5 mm 4.5 mm 5.5 mm	p. 2-15 p. 203 p. 1-9 p. 355
Front Fork: Air pressure Oil viscosity Oil amount ZR400B/550 ZX550 Oil level (extended, without main spring) ZR400B/550 ZX550	59 – 78 kPa (0.6 – 0.8 kg/cm ² , 8.5 – 11 psi) SAE 5W20 236 ±2.5 mL 229 ±2.5 mL 495 ±2 mm 472 ±2 mm		p. 1-9 p. 2-20 p. 2-20 p. 2-20

Item	Standard	Service Limit	See Page
Main spring free length ZR400B/550 ZX550	560.7 mm 510.2 mm	549 mm 500 mm	p. 209
Ignition System:			
Spark plug type Standard ZR400B/ZX550 Ⓐ Ⓘ Ⓝ Ⓢ Ⓤ ZR550 Ⓐ Ⓘ Ⓝ Ⓢ Ⓤ For cold wether and low speed riding ZR400B/ZX550 Ⓐ Ⓘ Ⓝ Ⓢ Ⓤ ZR550	NGK DPR9EA-9 or ND X27EPR-U9 NGK DP9EA-9 or ND X27EP-U9 NGK DR8ES or ND X24ESR-U NGK D8EA or ND X24ES-U NGK DPR8EA-9 or ND X24EPR-U9 NGK DP8EA-9 or ND X24EP-U9 Use standard plugs		p. 2-4
Spark plug gap ZR400B/ZX550 ZR550	0.8 – 0.9 mm 0.6 – 0.7 mm		p. 2-4

- Ⓐ : Australian Model Ⓘ : Italian Model Ⓝ : Norwegian Model
 Ⓢ : South African Model Ⓤ : US Model

"NOTE"

- Refer to p. xxx (shown in the "See Page" column) of the Base Manual.
- Refer to p.x-xx (shown in the "See Page" column) of this Supplement.

9-14 SUPPLEMENT—1984 MODEL

Torque and Locking Agent

Refer to p. 1-17 — p. 1-20, noting the following.

Parts	Threads Dia. (mm)	Quantity	Torque			Remarks
			N-m	kg-m	ft-lb	
Engine:						
Air suction valve cover bolts (US model)	6	8	9.8	1.0	87 in-lb	—
Carburetor holder bolts	6	8	12	1.2	104 in-lb	—
Engine mounting bolts (ZX550)	10	4	39	4.0	29	—
Wheels:						
Front axle nut (ZX550)	14	1	78	8.0	58	—
Rear axle nut (ZX550)	16	1	93	9.5	69	—
Rear sprocket nuts (ZX550)	10	6	39	4.0	29	—
Brakes:						
Anti-dive brake plunger assembly mounting bolts (ZX550)	5	4	3.9	0.40	35 in-lb	A
Anti-dive valve assembly mounting bolts (ZX550)	6	8	7.4	0.75	65 in-lb	A
Brake pipe nipples (ZX550)	10	4	15	1.5	11.0	—
Caliper mounting bolts:						—
Front	8	4	25	2.5	18.0	—
Rear	10	2	29	3.0	22	—
Front disc mounting Allen bolts (ZX550)	8	12	27	2.8	20	—
Rear caliper holder clamp bolt (ZX550)	8	1	6.4	0.65	56 in-lb	—
Steering:						
Handlebar clamp bolts	8	2	25	2.5	18.0	—
Handlebar holder bolts	32	2	74	7.5	54	—
Suspension:						
Rear shock absorber mounting bolts (ZX550)	12	2	49	5.0	36	—
Swing arm pivot shaft nut (ZX550)	14	1	88	9.0	65	—
Uni-trak links (ZX550):						
Rocker arm pivot shaft nut	12	1	49	5.0	36	—
Tie-rod bolts	12	3	49	5.0	36	—

ZX550-A1 Wiring Diagram
(US and Canada)

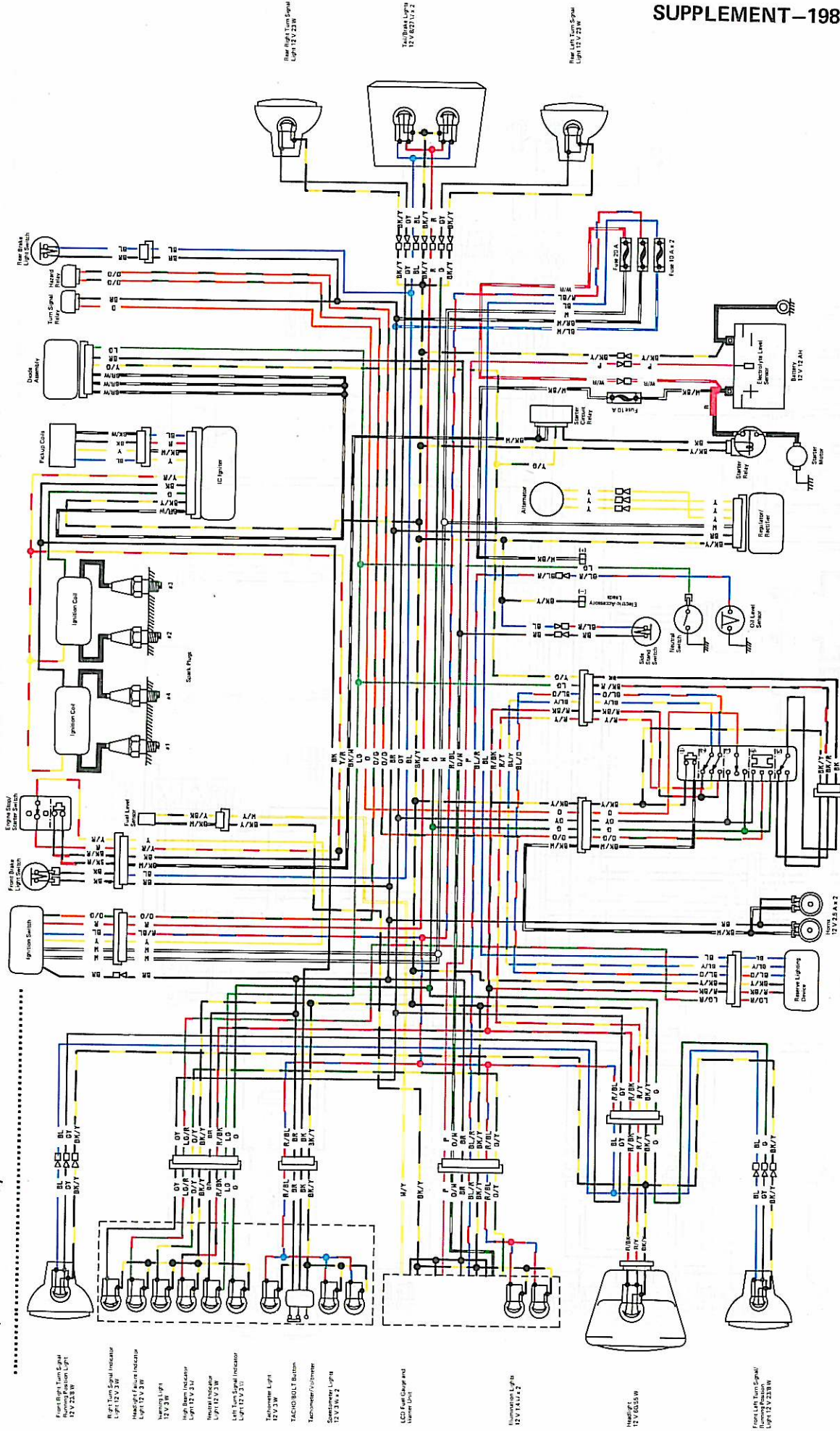

Color Code	Color
BL	Black
BR	Brown
BU	Blue
BY	Blue/Yellow
GR	Green
GR/BK	Green/Black
GR/Y	Green/Yellow
LD	Lead
OR	Orange
PK	Pink
RE	Red
W	White

Color Code	Color
BL	Black
BR	Brown
BU	Blue
BY	Blue/Yellow
GR	Green
GR/BK	Green/Black
GR/Y	Green/Yellow
LD	Lead
OR	Orange
PK	Pink
RE	Red
W	White

Color Code	Color
BL	Black
BR	Brown
BU	Blue
BY	Blue/Yellow
GR	Green
GR/BK	Green/Black
GR/Y	Green/Yellow
LD	Lead
OR	Orange
PK	Pink
RE	Red
W	White

Color Code	Color
BL	Black
BR	Brown
BU	Blue
BY	Blue/Yellow
GR	Green
GR/BK	Green/Black
GR/Y	Green/Yellow
LD	Lead
OR	Orange
PK	Pink
RE	Red
W	White

Color Code	Color
BL	Black
BR	Brown
BU	Blue
BY	Blue/Yellow
GR	Green
GR/BK	Green/Black
GR/Y	Green/Yellow
LD	Lead
OR	Orange
PK	Pink
RE	Red
W	White

Color Code	Color
BL	Black
BR	Brown
BU	Blue
BY	Blue/Yellow
GR	Green
GR/BK	Green/Black
GR/Y	Green/Yellow
LD	Lead
OR	Orange
PK	Pink
RE	Red
W	White

(12/24)

ZX550-A1 Wiring Diagram
(Other than US and Canada)

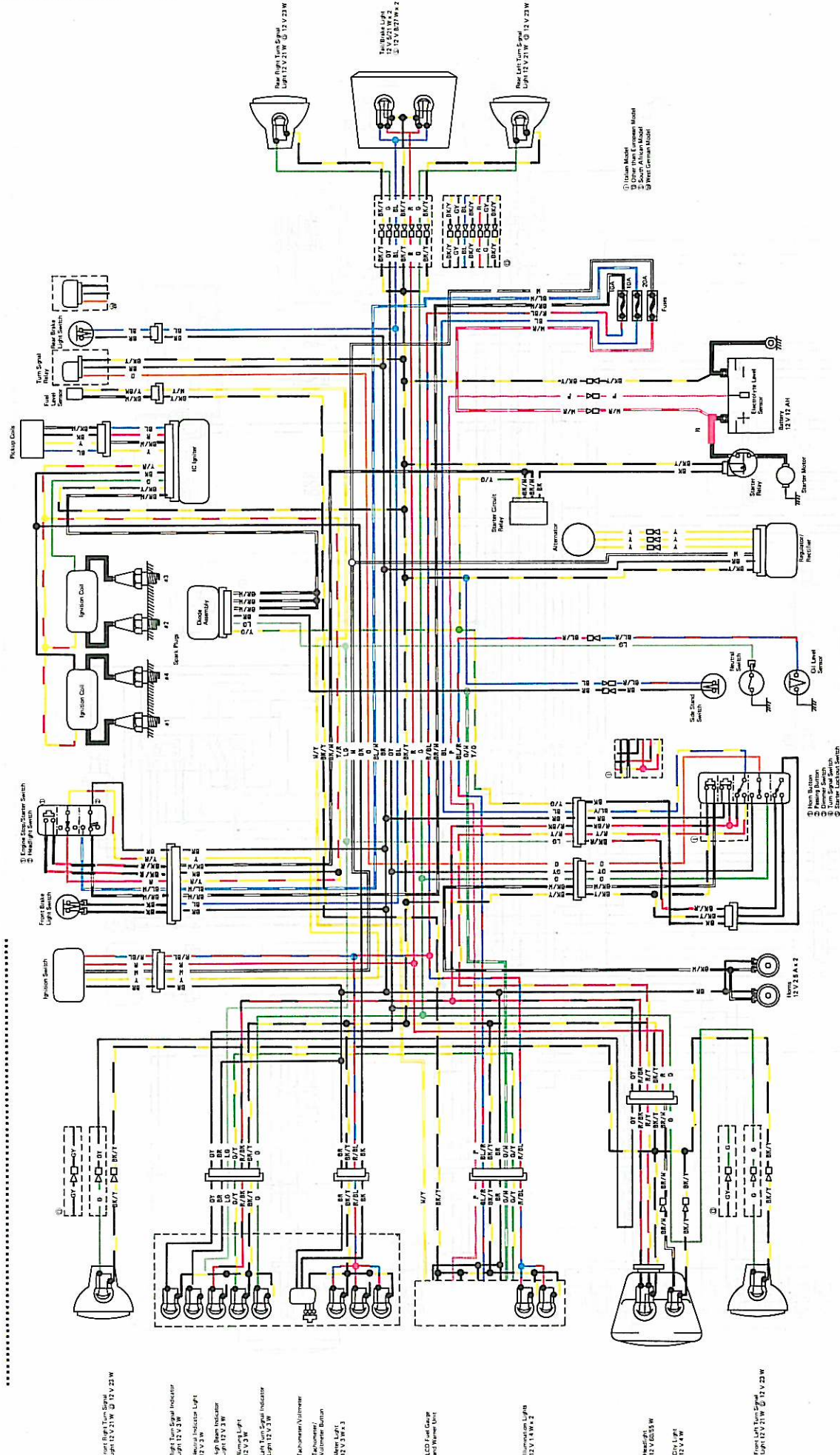

Legend for wire colors and components:

- Front Right Turn Signal Light 12 V 21 W
- Front Left Turn Signal Light 12 V 21 W
- High Beam Indicator Light 12 V 21 W
- Low Beam Indicator Light 12 V 21 W
- Rear Right Turn Signal Light 12 V 21 W
- Rear Left Turn Signal Light 12 V 21 W
- Tail Light 12 V 21 W
- Stop Light 12 V 21 W
- Fuel Gauge and Warning Unit
- Turn Signal Relay
- Turn Signal Light 12 V 21 W
- Ignition Switch
- Ignition Coil
- Spark Plug
- IC Igniter
- Battery 12 V 12 AH
- Alternator/Rectifier
- Starter Switch
- Stop Lockout Switch
- Headlight Switch
- Engine Stop/Start Switch
- Kill Switch
- Starter Lockout Switch

RIGHT HANDLEBAR SWITCH CONNECTIONS

Color	Headlight Switch	Engine Stop/Start Switch
Green	Y/R	Green
Blue	Y/R	Blue
Black	Y/R	Black
White	Y/R	White
Red	Y/R	Red
Orange	Y/R	Orange
Yellow	Y/R	Yellow
Purple	Y/R	Purple
Brown	Y/R	Brown
Grey	Y/R	Grey
Light Blue	Y/R	Light Blue
Light Green	Y/R	Light Green
Light Yellow	Y/R	Light Yellow
Light Purple	Y/R	Light Purple
Light Brown	Y/R	Light Brown
Light Grey	Y/R	Light Grey
Light Light Blue	Y/R	Light Light Blue
Light Light Green	Y/R	Light Light Green
Light Light Yellow	Y/R	Light Light Yellow
Light Light Purple	Y/R	Light Light Purple
Light Light Brown	Y/R	Light Light Brown
Light Light Grey	Y/R	Light Light Grey
Light Light Light Blue	Y/R	Light Light Light Blue
Light Light Light Green	Y/R	Light Light Light Green
Light Light Light Yellow	Y/R	Light Light Light Yellow
Light Light Light Purple	Y/R	Light Light Light Purple
Light Light Light Brown	Y/R	Light Light Light Brown
Light Light Light Grey	Y/R	Light Light Light Grey

IGNITION SWITCH CONNECTIONS

Color	Ignition Switch	Engine Stop/Start Switch	Headlight Switch	Turn Signal Switch
Green	Y/R	Green	Y/R	Green
Blue	Y/R	Blue	Y/R	Blue
Black	Y/R	Black	Y/R	Black
White	Y/R	White	Y/R	White
Red	Y/R	Red	Y/R	Red
Orange	Y/R	Orange	Y/R	Orange
Yellow	Y/R	Yellow	Y/R	Yellow
Purple	Y/R	Purple	Y/R	Purple
Brown	Y/R	Brown	Y/R	Brown
Grey	Y/R	Grey	Y/R	Grey
Light Blue	Y/R	Light Blue	Y/R	Light Blue
Light Green	Y/R	Light Green	Y/R	Light Green
Light Yellow	Y/R	Light Yellow	Y/R	Light Yellow
Light Purple	Y/R	Light Purple	Y/R	Light Purple
Light Brown	Y/R	Light Brown	Y/R	Light Brown
Light Grey	Y/R	Light Grey	Y/R	Light Grey
Light Light Blue	Y/R	Light Light Blue	Y/R	Light Light Blue
Light Light Green	Y/R	Light Light Green	Y/R	Light Light Green
Light Light Yellow	Y/R	Light Light Yellow	Y/R	Light Light Yellow
Light Light Purple	Y/R	Light Light Purple	Y/R	Light Light Purple
Light Light Brown	Y/R	Light Light Brown	Y/R	Light Light Brown
Light Light Grey	Y/R	Light Light Grey	Y/R	Light Light Grey

LEFT HANDLEBAR SWITCH CONNECTIONS

Color	Turn Signal Switch	Engine Stop/Start Switch	Headlight Switch	Starter Lockout Switch
Green	Y/R	Green	Y/R	Green
Blue	Y/R	Blue	Y/R	Blue
Black	Y/R	Black	Y/R	Black
White	Y/R	White	Y/R	White
Red	Y/R	Red	Y/R	Red
Orange	Y/R	Orange	Y/R	Orange
Yellow	Y/R	Yellow	Y/R	Yellow
Purple	Y/R	Purple	Y/R	Purple
Brown	Y/R	Brown	Y/R	Brown
Grey	Y/R	Grey	Y/R	Grey
Light Blue	Y/R	Light Blue	Y/R	Light Blue
Light Green	Y/R	Light Green	Y/R	Light Green
Light Yellow	Y/R	Light Yellow	Y/R	Light Yellow
Light Purple	Y/R	Light Purple	Y/R	Light Purple
Light Brown	Y/R	Light Brown	Y/R	Light Brown
Light Grey	Y/R	Light Grey	Y/R	Light Grey
Light Light Blue	Y/R	Light Light Blue	Y/R	Light Light Blue
Light Light Green	Y/R	Light Light Green	Y/R	Light Light Green
Light Light Yellow	Y/R	Light Light Yellow	Y/R	Light Light Yellow
Light Light Purple	Y/R	Light Light Purple	Y/R	Light Light Purple
Light Light Brown	Y/R	Light Light Brown	Y/R	Light Light Brown
Light Light Grey	Y/R	Light Light Grey	Y/R	Light Light Grey

Color Code

Color	Code
Green	G
Blue	B
Black	BL
White	W
Red	R
Orange	O
Yellow	Y
Purple	P
Brown	BR
Grey	GR
Light Blue	LB
Light Green	LG
Light Yellow	LY
Light Purple	LP
Light Brown	LBW
Light Grey	LGW
Light Light Blue	LLB
Light Light Green	LLG
Light Light Yellow	LLY
Light Light Purple	LLP
Light Light Brown	LLBW
Light Light Grey	LLGW

IGNITION SWITCH CONNECTIONS

Color	Ignition Switch	Engine Stop/Start Switch	Headlight Switch	Turn Signal Switch
Green	Y/R	Green	Y/R	Green
Blue	Y/R	Blue	Y/R	Blue
Black	Y/R	Black	Y/R	Black
White	Y/R	White	Y/R	White
Red	Y/R	Red	Y/R	Red
Orange	Y/R	Orange	Y/R	Orange
Yellow	Y/R	Yellow	Y/R	Yellow
Purple	Y/R	Purple	Y/R	Purple
Brown	Y/R	Brown	Y/R	Brown
Grey	Y/R	Grey	Y/R	Grey
Light Blue	Y/R	Light Blue	Y/R	Light Blue
Light Green	Y/R	Light Green	Y/R	Light Green
Light Yellow	Y/R	Light Yellow	Y/R	Light Yellow
Light Purple	Y/R	Light Purple	Y/R	Light Purple
Light Brown	Y/R	Light Brown	Y/R	Light Brown
Light Grey	Y/R	Light Grey	Y/R	Light Grey
Light Light Blue	Y/R	Light Light Blue	Y/R	Light Light Blue
Light Light Green	Y/R	Light Light Green	Y/R	Light Light Green
Light Light Yellow	Y/R	Light Light Yellow	Y/R	Light Light Yellow
Light Light Purple	Y/R	Light Light Purple	Y/R	Light Light Purple
Light Light Brown	Y/R	Light Light Brown	Y/R	Light Light Brown
Light Light Grey	Y/R	Light Light Grey	Y/R	Light Light Grey

LEFT HANDLEBAR SWITCH CONNECTIONS

Color	Turn Signal Switch	Engine Stop/Start Switch	Headlight Switch	Starter Lockout Switch
Green	Y/R	Green	Y/R	Green
Blue	Y/R	Blue	Y/R	Blue
Black	Y/R	Black	Y/R	Black
White	Y/R	White	Y/R	White
Red	Y/R	Red	Y/R	Red
Orange	Y/R	Orange	Y/R	Orange
Yellow	Y/R	Yellow	Y/R	Yellow
Purple	Y/R	Purple	Y/R	Purple
Brown	Y/R	Brown	Y/R	Brown
Grey	Y/R	Grey	Y/R	Grey
Light Blue	Y/R	Light Blue	Y/R	Light Blue
Light Green	Y/R	Light Green	Y/R	Light Green
Light Yellow	Y/R	Light Yellow	Y/R	Light Yellow
Light Purple	Y/R	Light Purple	Y/R	Light Purple
Light Brown	Y/R	Light Brown	Y/R	Light Brown
Light Grey	Y/R	Light Grey	Y/R	Light Grey
Light Light Blue	Y/R	Light Light Blue	Y/R	Light Light Blue
Light Light Green	Y/R	Light Light Green	Y/R	Light Light Green
Light Light Yellow	Y/R	Light Light Yellow	Y/R	Light Light Yellow
Light Light Purple	Y/R	Light Light Purple	Y/R	Light Light Purple
Light Light Brown	Y/R	Light Light Brown	Y/R	Light Light Brown
Light Light Grey	Y/R	Light Light Grey	Y/R	Light Light Grey

Scheduled Maintenance

Periodic Maintenance Chart (ZX550)

The scheduled maintenance must be done in accordance with this chart to keep the motorcycle in good running condition. The initial maintenance is vitally important and must not be neglected.

OPERATION	FREQUENCY	Whichever comes first		*ODOMETER READING						See Page
		Every	800 km	5,000 km	10,000 km	15,000 km	20,000 km	25,000 km	30,000 km	
Spark plug – clean		•	•	•	•	•	•	•	•	2-3
Spark plug – check †		•	•	•	•	•	•	•	•	2-3, 9-13
Valve clearance – check †		•	•	•	•	•	•	•	•	2-3
Air suction valve – check † (U)			•	•	•	•	•	•	•	9-18
Air cleaner element – clean			•		•		•			2-7, 9-18
Air cleaner element – replace	5 cleanings			•		•		•		–
Throttle grip play – check †		•	•	•	•	•	•	•	•	2-8
Idle speed – check †		•	•	•	•	•	•	•	•	2-8, 9-9
Engine vacuum synchronization – check †		•	•	•	•	•	•	•	•	2-9
Fuel system – check †				•		•		•		2-10
Cylinder head bolt tightness – check †		•		•		•		•		–
Cylinder head nut tightness – check †		•		•		•		•		–
Evaporative emission control system (C) – check †		•	•	•	•	•	•	•	•	9-18
Engine oil – change	year	•	•	•	•	•	•	•	•	2-10
Oil filter – replace		•		•		•		•		–
Fuel hose – replace	4 years									–
Clutch – adjust		•	•	•	•	•	•	•	•	9-18
Drive chain wear – check †			•	•	•	•	•	•	•	2-14
Drive chain – lubricate	300 km									2-14
Drive chain slack – check †	800 km									2-12, 9-12
Brake lining wear – check †			•	•	•	•	•	•	•	2-15
Brake fluid level – check †	month	•	•	•	•	•	•	•	•	2-16
Brake fluid – change	year			•		•		•		2-17
Brake hose and pipe – replace	4 years									9-21
Anti-dive brake plunger assembly – replace	2 years									9-21
Master cylinder cup and dust seal – replace	2 years									–
Caliper piston seal and dust seal – replace	2 years									–
Brake light switch – check †		•	•	•	•	•	•	•	•	2-24
Steering – check †		•	•	•	•	•	•	•	•	2-19
Steering stem bearing – lubricate	2 years					•				2-20
Front fork oil – change				•		•		•		2-20, 9-12
Tire wear – check †			•	•	•	•	•	•	•	2-21, 9-11
Wheel bearing – lubricate	2 years					•				2-22
Speedometer gear – lubricate	2 years					•				2-22
Swing arm pivot, uni-trak linkage – lubricate				•		•		•		9-21
General lubrication – perform			•	•	•	•	•	•	•	2-23
Nut, bolt, and fastener tightness – check †		•		•		•		•		2-24

* : For higher odometer readings, repeat at the frequency interval established here.
 † : Replace, add, adjust, clean, or torque if necessary.
 (C) : California vehicle only (U) : US vehicle only

Air Suction Valves (US Model)

The air suction valve is essentially a check valve which allows fresh air to flow only from the air cleaner into the exhaust port. Any air that has passed the air suction valve is prevented from returning.

Inspection

- Remove the air suction valves.
- Visually inspect the reeds for cracks, folds, warps, heat damage, or other damage.
- ★ If there is any doubt as to the condition of the reed, replace the air suction valve as an assembly.

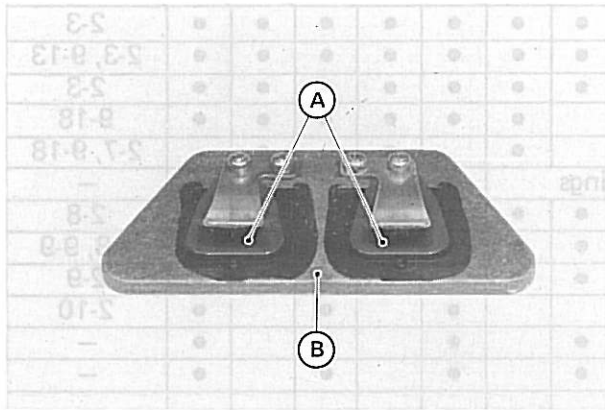

A. Reeds B. Valve Holder

- Check the reed contact areas of the valve holder for grooves, scratches, any signs of separation from the holder, or heat damage.
- Check the sealing lip located around the valve holder for the same items.
- ★ If there is any doubt as to the condition of the reed contact areas, or the sealing lip replace the air suction valve as an assembly.
- ★ If any carbon or other foreign particles have accumulated between the reed and reed contact area, wash the valve assembly clean with a high flash-point solvent.

CAUTION

- Do not scrape off the deposits with a scraper as this could damage the rubber, requiring replacement of the suction valve assembly.

Air Cleaner Element (ZX550)

Refer to p. 2-7, noting the following.

- The air cleaner element on the ZX550 is a dry type element. See the instruction of the left side dry type element for servicing the ZX550's element.

**Evaporative Emission Control System
(US California Vehicle only)**

The Evaporative Emission Control System routes fuel vapors from the fuel system into the running engine or stores the vapors in a canister when the engine is stopped. Although no adjustments are required, a thorough visual inspection must be made at the intervals specified by the Periodic Maintenance Chart.

Inspection

- Check that the hoses are securely connected.
- Replace any kinked, deteriorated or damaged hoses.

Clutch (ZX550)

WARNING

- To avoid a serious burn, never touch the engine or exhaust pipes during clutch adjustment.

Adjustment

- Loosen the locknut and mounting nuts.
- Turn one cable adjuster and slide the other until the correct clutch lever play is obtained. Tighten the locknut and mounting nuts.

Clutch Lever Play

2 – 3 mm

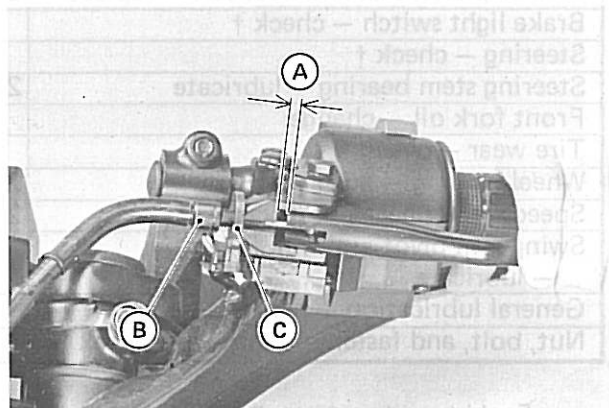

A. Clutch Lever Play C. Locknut
B. Adjuster

Evaporative Emission Control System

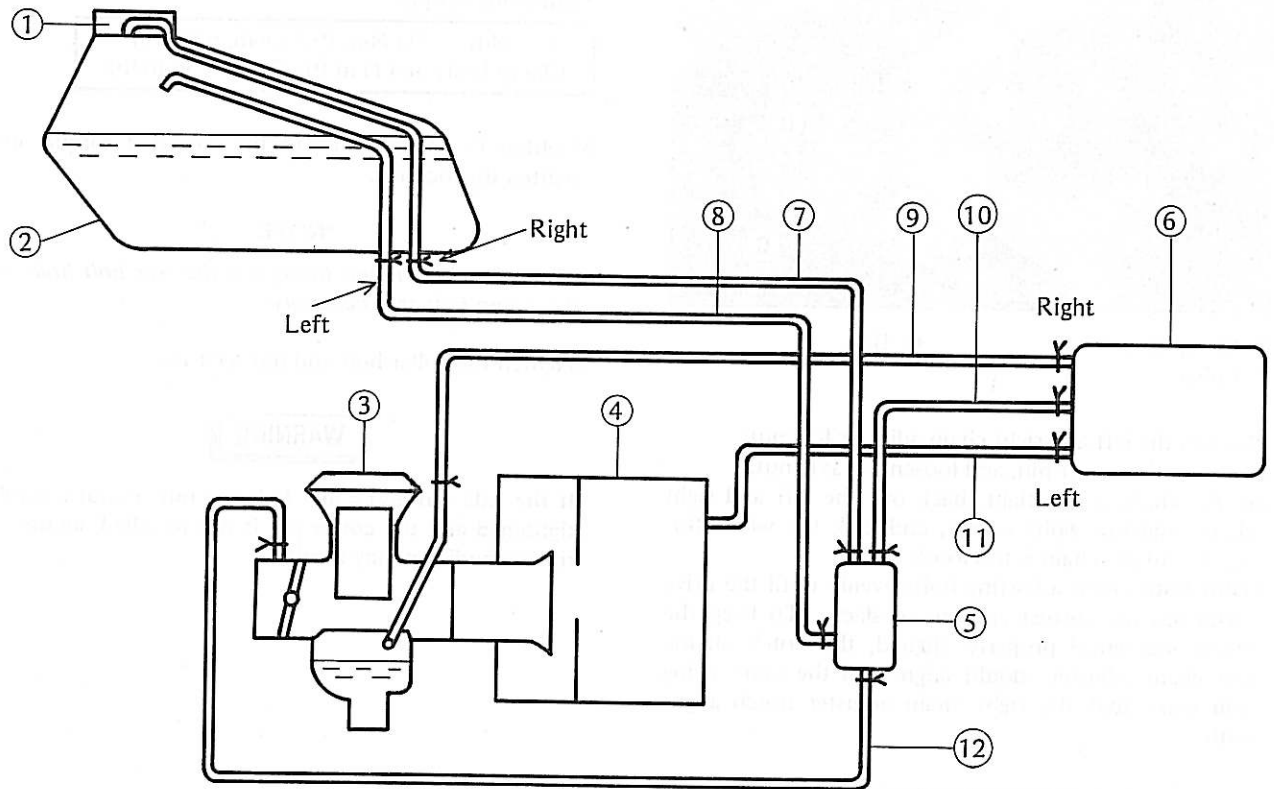

- | | | |
|------------------------|---------------------------|---------------------------|
| 1. Tank Cap | 5. Liquid/Vapor Separator | 9. Breather Hose (Yellow) |
| 2. Fuel Tank | 6. Canister | 10. Breather Hose (Blue) |
| 3. Carburetors | 7. Breather Hose (Blue) | 11. Purge Hose (Green) |
| 4. Air Cleaner Housing | 8. Fuel Return Hose (Red) | 12. Vacuum Hose (White) |

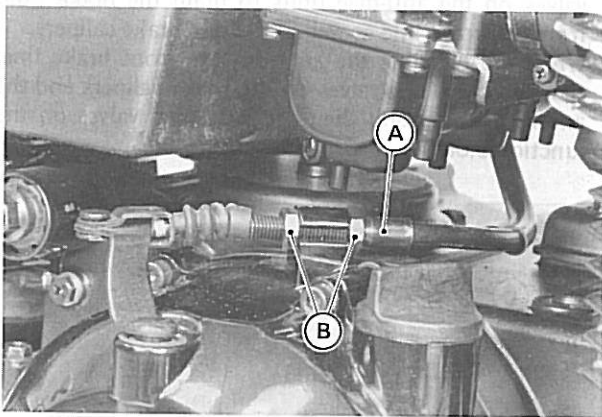

A. Adjuster B. Mounting Nuts

WARNING

○Be sure the upper end of the clutch outer cable is fully seated in its fitting, or it could slip into place later, creating enough cable play to prevent clutch disengagement, resulting in hazardous riding condition.

●After the adjustment is made, start the engine and check that the clutch does not slip and that it releases properly.

.....
Drive Chain (ZX550)

Slack Adjustment

- Loosen the locknut and unscrew the clamp bolt.
- Loosen the caliper holder collar bolt and nut.

CAUTION

○If you don't loosen the collar bolt and nut, it may lead to the brake parts damage when the adjusters are set.

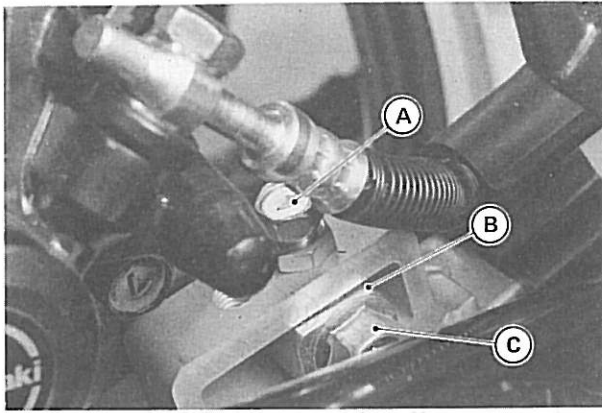

A. Clamp Bolt
B. Collar
C. Bolt

- Loosen the left and right chain adjuster locknuts.
- Remove the cotter pin, and loosen the axle nut.
- If the chain is too tight, back out the left and right chain adjusting bolts evenly, and kick the wheel forward until the chain is too loose.
- Turn both chain adjusting bolts evenly until the drive chain has the correct amount of slack. To keep the chain and wheel properly aligned, the notch on the left chain adjuster should align with the same swing arm mark that the right chain adjuster notch aligns with.

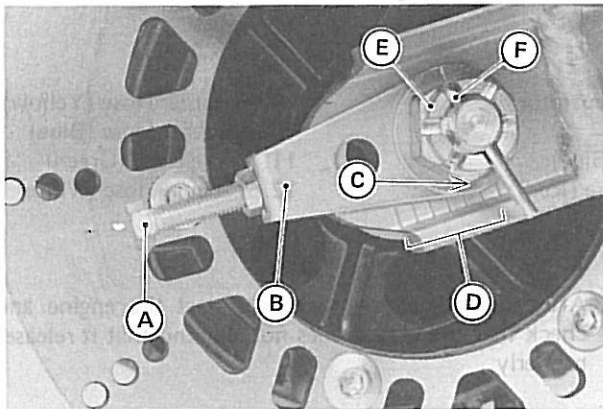

A. Adjusting Bolt
B. Chain Adjuster
C. Notch
D. Swing Arm Marks
E. Axle Nut
F. Cotter Pin

“NOTE”

○ Wheel alignment can also be checked using the straight-edge or string method.

WARNING

○ Misalignment of the wheel will result in abnormal wear, and may result in an unsafe riding condition.

- Tighten both chain adjuster locknuts.
- Tighten the axle nut.
- Rotate the wheel, measure the chain slack again at the tightest position, and readjust if necessary.

- Insert a new cotter pin through the axle nut and axle, and spread its ends.

Tightening Torque

Axle Nut:	93 N-m (9.5 kg-m, 69 ft-lb)
Clamp Bolt:	6.4 N-m (0.65 kg-m, 56 in-lb)

- Tighten the clamp bolt to the specified torque and tighten the locknut.

“NOTE”

○ When the chain is too loose, use the rear bolt hole for the clamp bolt as if necessary.

- Tighten the collar bolt and nut securely.

WARNING

○ If the axle nut and collar bolt and nut are not securely tightened and the cotter pin is not installed, an unsafe riding condition may result.

.....
Brakes (ZX550)
.....

Brake Fluid:

Refer to p. 2-16 – p. 2-18, noting the following.

- When the changing the front brake fluid, use the bleed valves on the anti-dive units to drain the brake fluid from the brake line as well as the disc brake calipers.
- When the bleeding the air from the front brake line, first use the bleed valves on the brake calipers and the anti-dive units, and then use the bleed valves on the junction blocks.

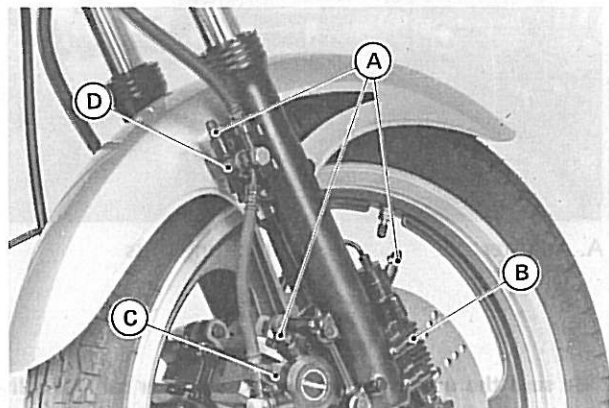

A. Air Bleed Valves
B. Anti-Dive Unit
C. Brake Caliper
D. Junction Block

.....
Front Fork (ZX550)

Add the following maintenance.

Replacement of Anti-Dive System Parts

In accordance with the Periodic Maintenance Chart, replace the following anti-dive system parts.

Periodic Replacement Parts of Anti-Dive System

Brake plunger assembly Metal pipe (between anti-dive unit and junction block)

- Be sure to bleed the air from the brake line after replacement.

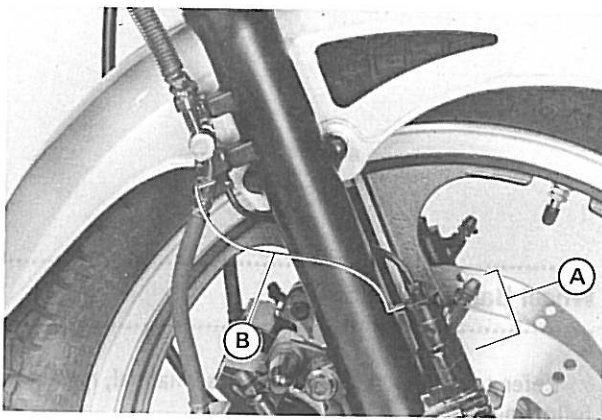

A. Brake Plunger Assembly B. Metal Pipe

.....
Swing Arm (ZX550)
Uni-Trak (ZX550)

Lubrication

- Remove the rear wheel and swing arm.
- Remove the uni-trak rocker arm and tie-rods.
- Remove the dust seals and O-rings, and pull out the sleeves out of the bearings or bushings.
- Using a high flash-point solvent, wash the sleeves, needle bearings, and bushings of old grease, and dry them.
- Inspect the sleeves, bearings, bushings, dust seals, and O-rings for abrasions, color change, or other damage.
- ★ If there is any doubt as to the condition of them, replace them with new ones.
- Apply a molybdenum disulfide chassis assembly grease to the needle bearings, bushings, and sleeves.
- Install the uni-trak rocker arm and tie-rods.
- Install the swing arm and rear wheel.

Non-scheduled Maintenance

.....
Evaporative Emission Control System
(US California Vehicle only)

Liquid/Vapor Separator:

Separator Inspection

- Disconnect the hoses from the liquid/vapor separator, and remove the separator from the motorcycle.
- Visually inspect the separator for cracks and other damage.
- ★ If the separator has any crack or bad damage, replace it with a new one.

Separator Test

- Connect the hoses to the separator, and install the separator on the motorcycle.
- Disconnect the breather hose from the separator, and inject about 20 mL of gasoline into the separator through the hose fitting.
- Disconnect the fuel return from the fuel tank.
- Run the open end of the return hose into the container level with the tank top.
- Start the engine, and let it idle.
- ★ If the gasoline in the separator comes out of the hose, the separator works well. If it does not, replace the separator with a new one.

Canister:

Canister Inspection

- Remove the canister, and disconnect the hoses from the canister.
- Visually inspect the canister for cracks and other damage.
- ★ If the canister has any crack or bad damage, replace it with a new one.

"NOTE"

○ *The canister is designed to work well through motorcycle's life without any maintenance if it is used under normal condition.*

CAUTION

○ If gasoline, solvent, water or any other liquid enters the canister, canister's vapor absorbing capacity is greatly reduced, and there is no way to recover it to the original level. In that case, replace the canister with a new one.

Fuel Tank and Cap:

Cap Inspection

- Visually inspect the gasket on the tank cap for any damage.
- ★ Replace the gasket if it is damaged.

- Blow the air vent in the tank cap free with compressed air.

Tank Inspection

- Remove the hoses from the fuel tank, and open the tank cap.
- Check to see if the breather and fuel return pipes in the tank do not clog up.
- ★ If they are clogged, blow them free with compressed air.

.....
Wheel Balance (ZX550)

Refer to p. 31 – p. 32 of the Base Manual, noting the following.

Installation of Balance Weight:

- Check that the weight portion has any play on the blade-and-clip plate.
- ★ If it does, discard it.
- Lubricate the balance weight blade, tire bead, and rim flange with a soap and water solution or rubber lubricant. This helps the balance weight slip on the rim flange.

CAUTION

○ Do not lubricate the tire bead with engine oil or gasoline because they will deteriorate the tire.

- Install the balance weight on the rim.
- Slip the weight on the rim flange by pushing or lightly hammering the weight in the direction shown in the figure.
- Check that the blade and weight seat fully on the rim flange, and that the clip is hooked over the rim ridge and reaches rim flat portion.

WARNING

- If the balance weight has any play on the rim flange, the blade and/or clip of the weight are widened. Replace the loose balance weight.
- Do not reuse used balance weights.

Installing Balance Weight

(a) Press or lightly hammer the weight in.

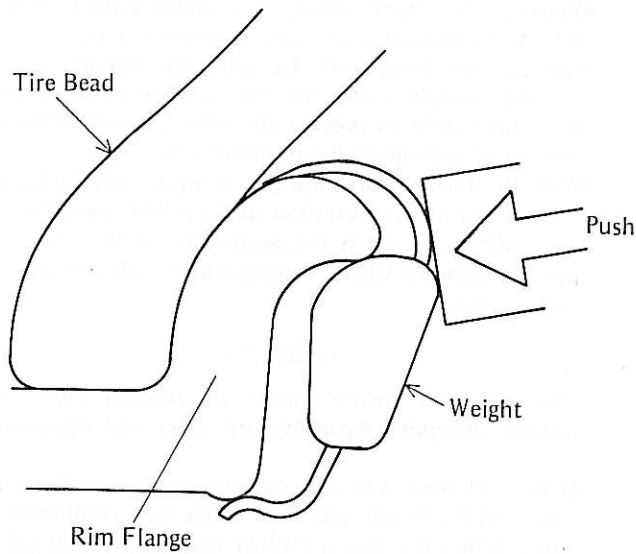

(b) Installation completed.

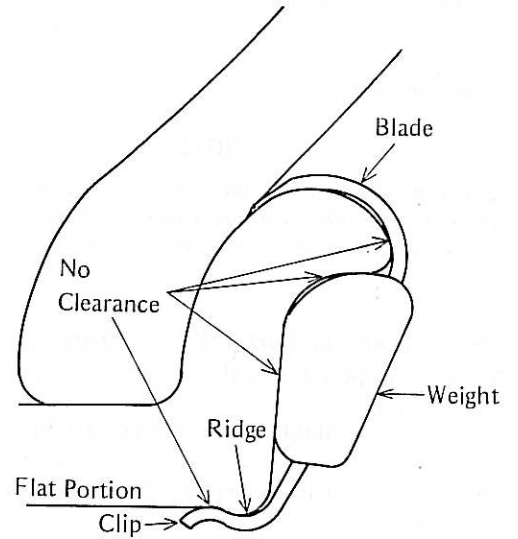

Balance Weight

Part Number	Weight (grams)
41075-1014	10
41075-1015	20
41075-1016	30

Removal of Balance Weight:

(a) When the tire is not on the rim.

- Push the blade portion toward the outside with a regular tip screw driver, and slip the weight off the rim flange.
- Discard the used balance weight.

Removing Balance Weight (without tire on rim) 482531

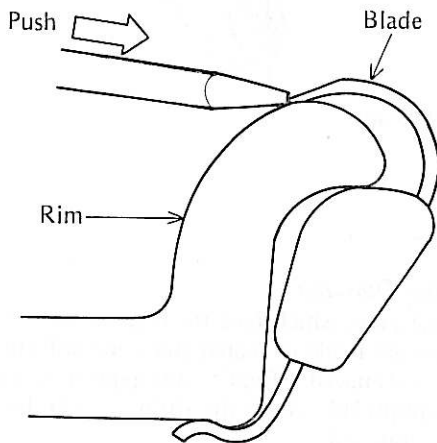

(b) When the tire is on the rim.

- Pry the Balance weight off the rim flange using a regular tip screw driver as shown in the figure.
- Insert a tip of the screw driver between the tire bead and weight blade until the end of the tip reaches the end of the weight blade.
- Push the driver grip toward the tire so that the balance weight slips off the rim flange.
- Discard the used balance weight.

Removing Balance Weight (with tire on rim) 482532

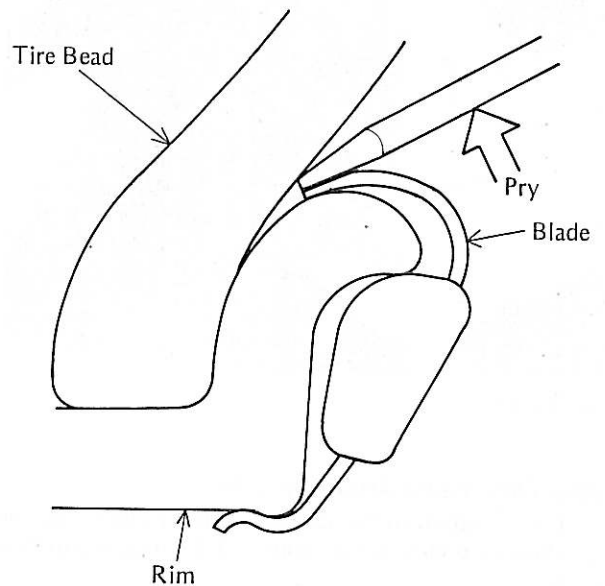

.....
Front Fork (ZX550)
.....

Refer to the Base Manual, noting the following.

Anti-Dive System:

"NOTE"

○Do not disassemble the anti-dive valve and brake plunger assemblies for repair or replacement of internal parts. Always replace them as assemblies.

Brake Fluid and Fork Oil Leak Inspection

- Visually inspect the anti-dive unit for brake fluid and fork oil leak.
- ★If the brake fluid leaks, replace the brake plunger assembly.
- ★If the fork oil leaks, replace the O-rings or anti-dive valve assembly.

Brake Plunger Assembly Test

The brake plunger assembly can be tested by separating it from the anti-dive valve assembly with the brake line connected to the brake plunger assembly.

- Separate the plunger assembly from the anti-dive valve assembly.
- Unbolt the brake line junction from the fork leg to prevent the metal pipe from being deformed.
- Check to see if the plunger in the brake plunger assembly comes out by a 2 mm when the front brake is lightly applied, and check to see if the plunger goes in smoothly when it is pushed on in with your finger.
- ★If the plunger does not move lightly or it has stuck in the body, replace the brake plunger assembly.

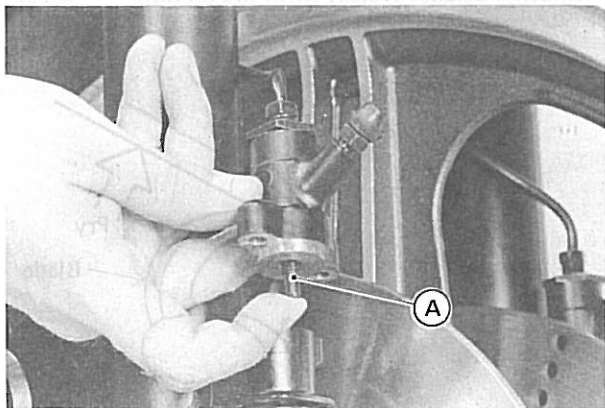

A. Plunger

Anti-Dive Valve Assembly Test

The operation of the anti-dive valve assembly can be checked by removing the front fork leg from the motorcycle.

- Separate the brake plunger assembly from the anti-dive valve assembly with the brake line connected.
- Remove the top plug, and take the fork main spring out of the fork tube.
- Remove the front wheel, disc brake caliper, front fender and brake line junction from the fork leg.
- Remove the front fork leg with its anti-dive valve assembly installed and tape the equalizing hole in the fork inner tube to prevent the fork oil from flowing out during anti-dive valve assembly test.
- With the fork leg held upright, compress the fork leg, and see that the compression stroke is light and smooth when the valve rod is not pushed in and that there is notable damping when the valve rod is pushed in with a suitable rod.

"NOTE"

○The extension stroke should be smooth with the notable damping regardless of valve rod positions.

★If the fork leg has heavy compression stroke when the valve rod is left released, or if it has light compression stroke when the rod is pushed in; the anti-dive valve assembly does not operate properly necessitating replacement of the anti-dive assembly.

Valve Assembly Test

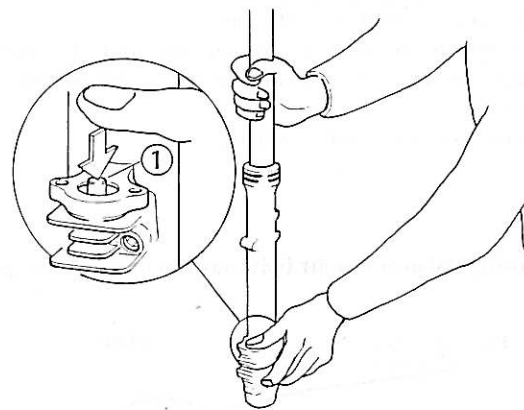

1. Suitable Rod

Metal Pipe Damage

- The metal pipes which feed the brake fluid to the anti-dive units are made of plated steel, and will rust if the plating is damaged. Replace the pipe if it is rusted, cracked (especially check the fittings), or if the plating is badly scratched.

Charging System (ZX550)

Refer to the Base Manual, noting the following.

Regulator/Rectifier Inspection

Regulator Test

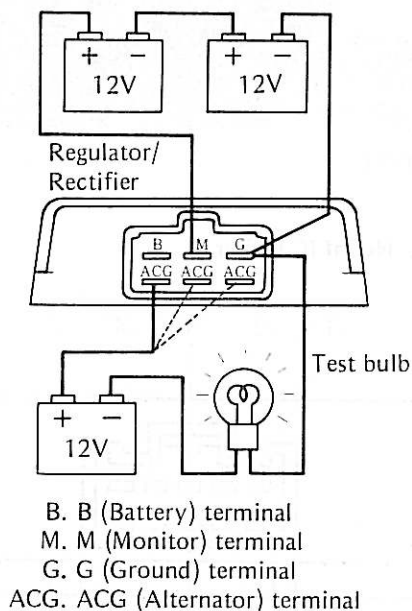

Ignition System (ZX550)

Safety Instruction:

There are a number of important precautions that must be observed when servicing the transistorized ignition system. Failure to observe these precautions can result in serious system damage. Learn and observe all the rules listed below.

- (1) **Because of limited capacity of the voltage regulating circuit in the IC igniter, do not disconnect the battery leads or any other electrical connections when the ignition switch is on, or while the engine is running. This is to prevent IC igniter damage.**
- (2) **Do not install the battery backwards. The negative side is grounded. This is to prevent damage to the diodes and IC igniter.**

Ignition System Inspection:

If trouble is suspected in the ignition system, check the following items. Before inspecting these items, make sure that all connectors and leads in the ignition system are clean, tight, and in good condition.

1. Dynamic Ignition Timing Inspection
2. Checking Power Supply to IC Igniter
3. Ignition Coil Inspection
4. Pickup Coil Inspection
5. IC Igniter Inspection
6. Switches Inspection
7. Diodes Inspection

Dynamic Ignition Timing Inspection

Ignition Timing/Engine Speed Relationship

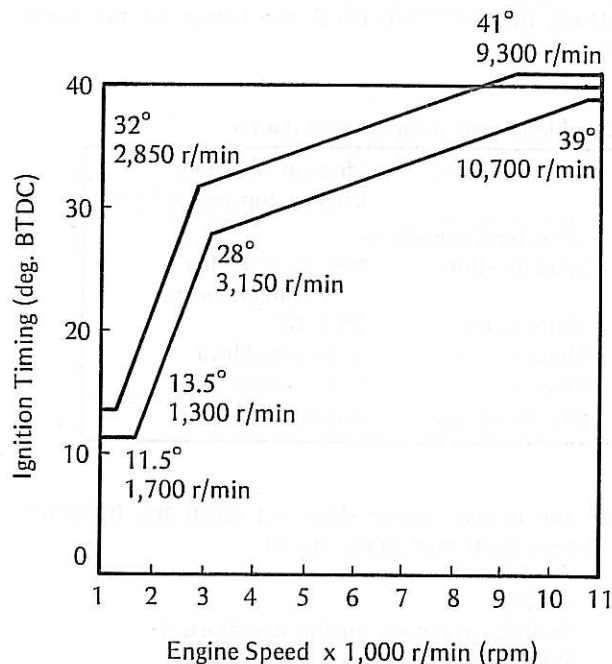

- Connect strobe light to the #1 or #4 spark plug lead in the manner prescribed by the manufacturer in order to check the ignition timing under operating conditions.
- Start the engine, and aim the strobe light at the timing marks on the timing rotor.
- Check the ignition timing at low and high engine speeds.

Checking Engine Speed

Low Speed:	Below 1,300 r/min (rpm)
High Speed:	Above 1,700 r/min (rpm)

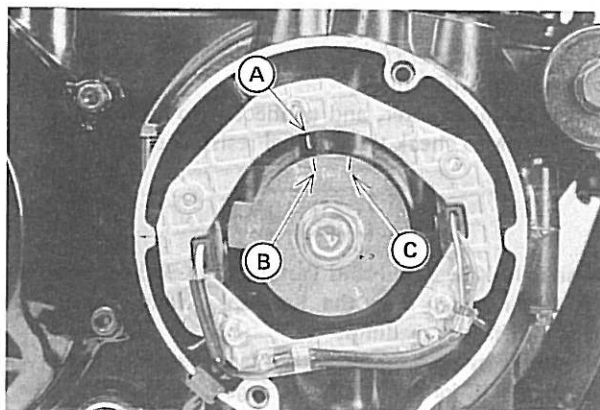

A. Timing mark
 B. "F" mark
 C. Full advanced mark

9-26 SUPPLEMENT—1984 MODEL

- At low speed, the "F" mark on the timing rotor should be aligned with the timing mark on the engine.
- At high speed, the timing mark on the engine should be pointed between the "F" mark and the full advanced mark. As the engine speed rises, the full advanced mark should be closed gradually with the timing mark.
- ★If the ignition timing is incorrect, replace IC igniter.

Checking Power Supply to IC Igniter

- Disconnect the IC igniter 10-pin connector.
- Using the voltmeter, check the voltage of the power supply leads.

Checking Power Supply to IC Igniter

Switch Position:	Ignition switch ON Engine stop switch RUN.
Voltmeter Connections:	
Lead location	Female IC igniter 10-pin connector
Meter range	25 V DC
Meter (+) →	Yellow/red lead
Meter (-) →	Black/yellow lead
Meter Reading:	Battery voltage

- ★If the battery power does not reach the IC igniter, inspect the power supply circuit.
 - Fuse (main)
 - Diodes
 - Switches (ignition, engine stop/starter)
 - Wires and Connectors

Ignition Coil Inspection

Refer to p. 221 – 222, p. 300 of the Base Manual.

Pickup Coil Inspection

Refer to p. 301 of the Base Manual, noting the following.

- Check the pickup coil air gaps (clearance between the timing rotor projection and the pickup coil core).
- ★If both air gaps are not equal, reposition the pickup coils. Recommended air gaps is 0.4 – 0.6 mm.

IC Igniter Inspection

- Remove the IC igniter.
- Zero the ohmmeter, and connect it to terminals of the IC igniter to check the internal resistance of the igniter.

CAUTION

- Use only Kawasaki Hand Tester 57001-983 for this test. A tester other than the Kawasaki Hand Tester may show different readings.
- If a megger or a meter with a large-capacity battery is used, the IC igniter will be damaged.

- ★Replace the IC igniter if the reading is not specified value.

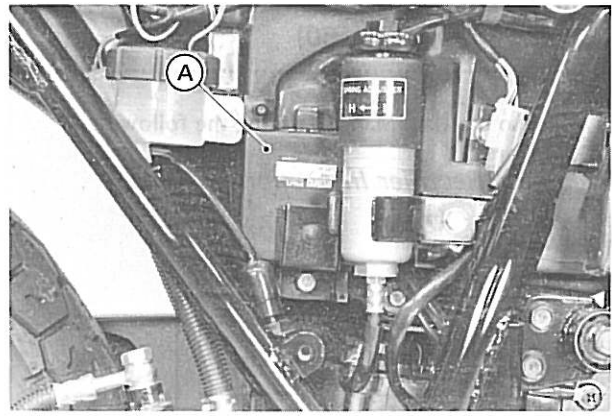

A. IC Igniter

Terminal No. of IC Igniter

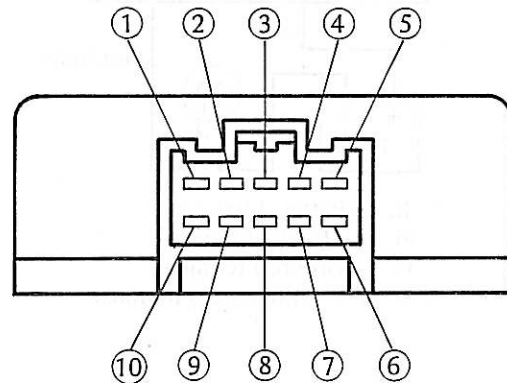

Switches Inspection

- Using the ohmmeter, check to see that only the connections shown in the table have continuity (about zero ohms).
- ★If the switch has open or a short, repair it or replace it with new one.

Engine Stop Switch Connections

	R	Y/R
OFF		
RUN	○	○

Side Stand Switch Connections

	BL/R	BR
When the side stand is left up	○	○
When the side stand is left down		

Starter Lockout Switch Connections

	BK/Y	BK	BK/R
When the clutch lever is pulled in	○	○	
When the clutch lever is released			○

Neutral Switch Connections

	LG	
When the gears are in neutral		
When the gears are not in neutral		

Ignition Switch Connections

	BR	W	Y	BL	R	W/BK	O/G
OFF, LOCK							
ON							
P(Park)							

Only on US, Canada

IC Igniter Internal Resistance

		Tester (+) Lead Connection									
		1	2	3	4	5	6	7	8	9	10
Tester (-) Lead Connection	1		D	D	D	D	D	D	D	D	∞
	2	D		D	D	D	D	D	D	D	∞
	3	C	C		B	B	B	B	B	B	∞
	4	∞	∞	∞		∞	∞	∞	∞	∞	∞
	5	∞	∞	∞	∞		∞	∞	∞	∞	∞
	6	C	C	B	A	A		A	O	O	∞
	7	C	C	B	A	A	A		A	A	∞
	8	C	C	B	A	A	O	A		O	∞
	9	C	C	B	A	A	O	A	O		∞
	10	∞	∞	∞	∞	∞	∞	∞	∞	∞	

Value (kΩ)	
O	Zero
A	0.3 – 4.2
B	6.6 – 21.4
C	25 – 75
D	125 – 375
∞	Infinity

Measured with the Kawasaki Hand Tester 57001-983.
A tester other than the Kawasaki Hand Tester may show different readings.

Diodes Inspection

- Disconnect the diode assembly.
- Zero the ohmmeter, and connect it to each diode terminals to check the resistance in both directions.
- ★ The resistance should be low in one direction and more than ten times as much in the other direction. If any diode shows low or high in both directions, the diode is defective and the diode assembly must be replaced.

"NOTE"

○ The actual meter reading varies with the meter used and the individual diode, but, generally speaking, the lower reading should be from zero to the first 1/2 of the scale.

Polarity of Diode

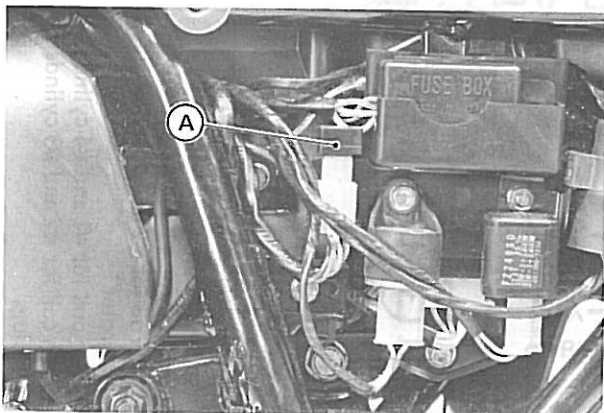

A. Diode Assembly

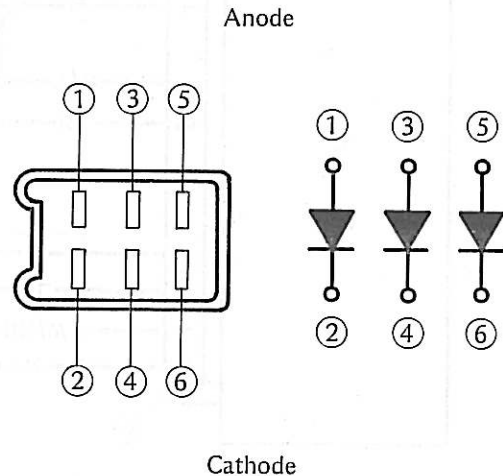

Cathode

Igniton System Wiring Diagram

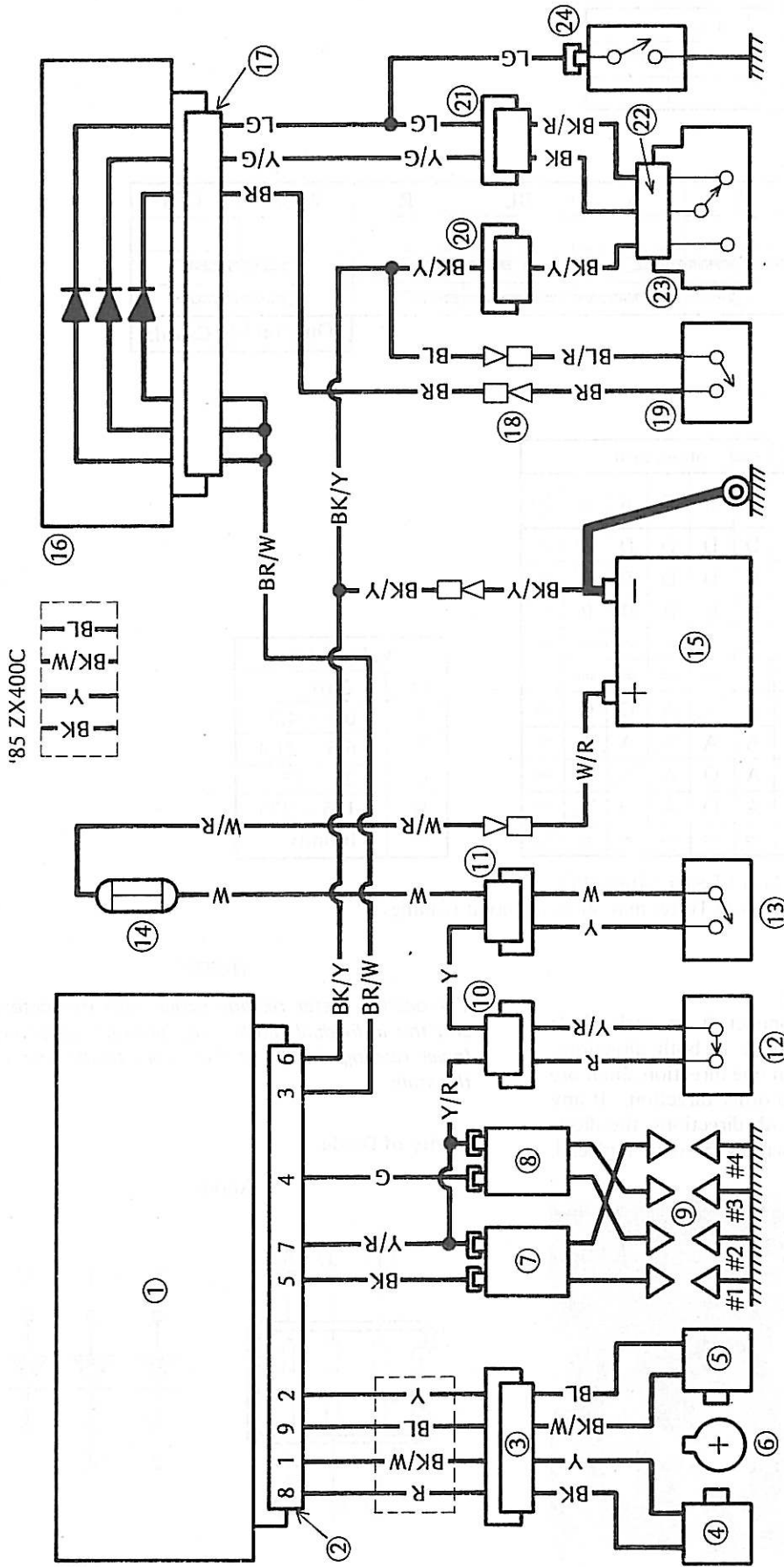

- 1. IC igniter
- 2. IC igniter 10-pin connector
- 3. Pickup coil 4-pin connector
- 4. Pickup coil for #1 and #4 cylinders
- 5. Pickup coil for #2 and #3 cylinders
- 6. Timing rotor
- 7. Ignition coil for #1 and #4 cylinders
- 8. Ignition coil for #2 and #3 cylinders
- 9. Spark plugs
- 10. Engine stop switch 9-pin connector (US model: 6-pin connector)
- 11. Ignition switch 6-pin connector
- 12. Engine stop switch
- 13. Ignition switch
- 14. 20A Fuse
- 15. Battery
- 16. Diodes
- 17. Diode assembly 6-pin connector
- 18. Side stand switch leads
- 19. Side stand switch
- 20. 6-pin connector
- 21. 6-pin connector
- 22. Starter lockout switch 3-pin connector
- 23. Starter lockout switch
- 24. Neutral switch

Electric Starter System (ZX550)

Checking Power Supply to Starter Relay

- Remove the left side cover and disconnect the 2-pin connector from the starter relay.
- Using a multimeter, check the voltage of the power supply wires.
- ★ If the meter does not show the specified reading, inspect the power supply and ground side circuits.
 - Fuse (main)
 - Relay (starter circuit)
 - Switches (ignition, engine stop/starter, starter lock-out, and/or neutral)
 - Wires and connectors
- ★ If the meter shows the specified reading, inspect the starter relay and/or starter motor.

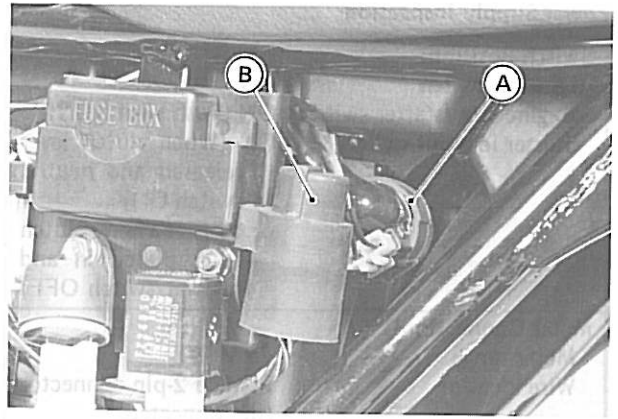

A. Starter Relay

B. Starter Circuit Relay

**Ignition System Wiring Diagram
(US and Canadian Model's shown)**

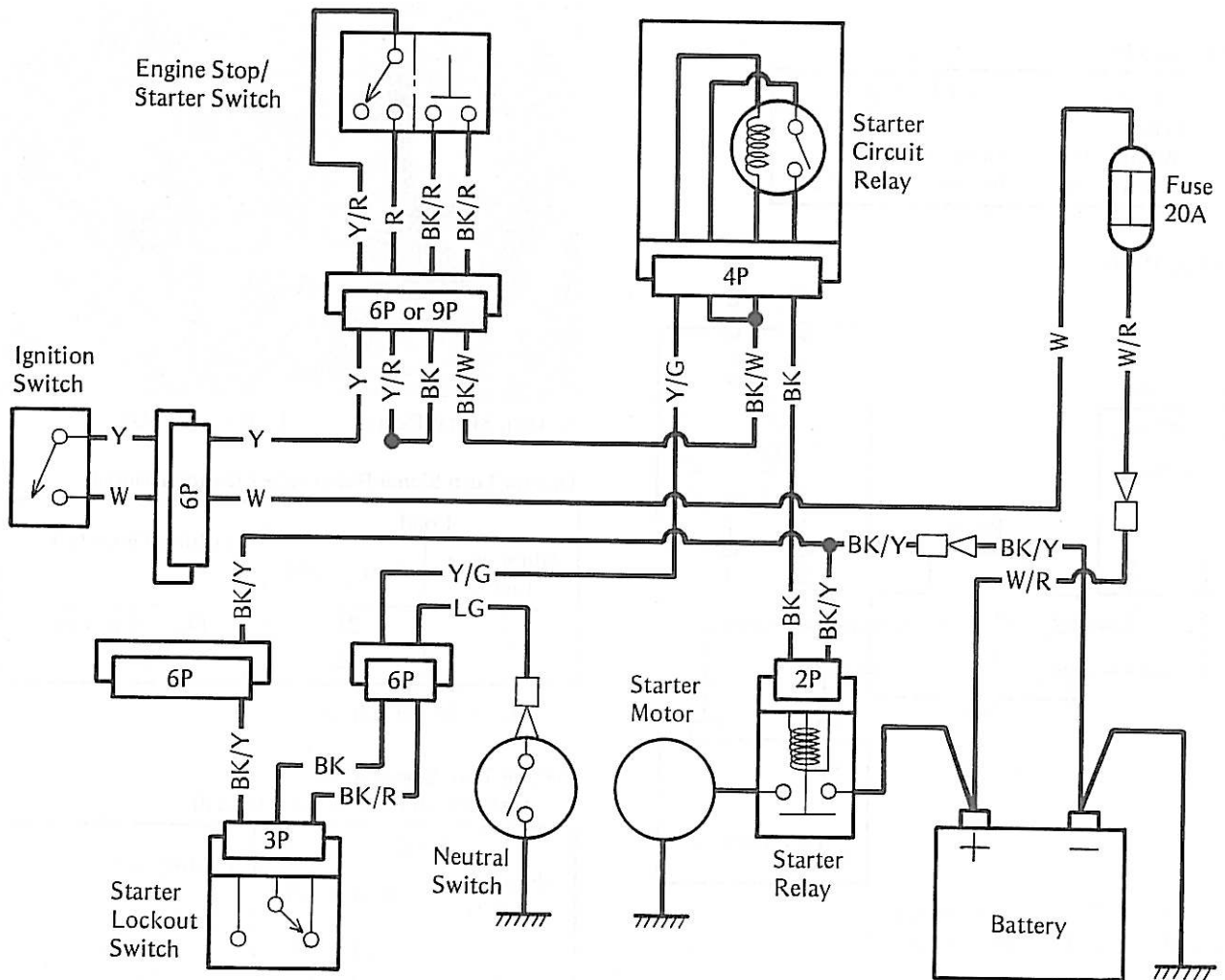

9-30 SUPPLEMENT—1984 MODEL

Power Supply Inspection

Switch Position:	
Ignition switch	ON
Engine stop/starter switch	ON (Push with RUN)
Starter lockout switch	ON (When clutch lever released and neutral switch ON) or OFF (When clutch lever pulled in and neutral switch OFF)
Meter Connections:	
Meter range	25 V DC
Wire location	Female 2-pin connector (disconnected)
Meter (+) →	Black wire
Meter (-) →	Black/yellow wire
Meter Reading:	Battery voltage

Starter Circuit Relay Inspection

- Remove the relay.
- Connect the ohmmeter and one 12-volt battery to the relay as shown.
- ★ If the relay does not work as specified, the relay is defective.

Testing Relay

Meter range:	x 1 Ω range
Criteria:	
When battery is connected →	0 Ω
When battery is disconnected →	$\infty \Omega$

Testing Relay

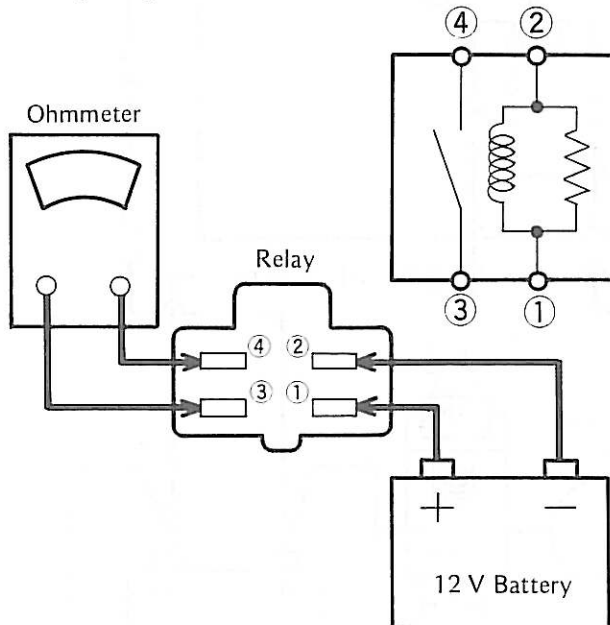

- ① and ② : Relay Coil Terminals
③ and ④ : Relay Switch Terminals

Switch Inspection

Refer to p. 9-26 – p. 9-27.

Starter Relay Inspection

Refer to p. 225 – 226 of the Base Manual.

Starter Motor Inspection

Refer to p. 226 – 228 of the Base Manual.

Turn Signal Circuit

Refer to p. 234 – 235 of the Base Manual, noting following.

Turn Signal Relay Inspection

- Remove the turn signal relay.
- Connect one 12-volt battery and turn signal lights as indicated in the figure, and count how many times the lights flash for one minute.
- ★ If the lights do not flash as specified, replace the turn signal relay.

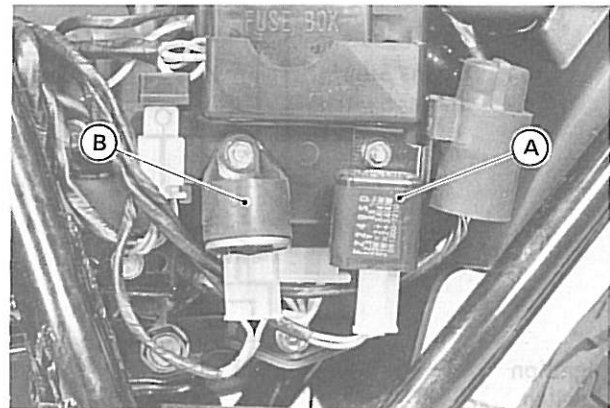

A. Turn Signal Relay B. Hazard Relay

Testing Turn Signal Relay (West German Model)

Number of Lights	Load		Flashing Times (c/m*)
		Wattage (W)	
1		21	More than 150
2		42	75 – 95

* : Cycle(s) per minute

Testing Turn Signal Relay (other than West German Model)

Number of Lights	Load		Flashing Times (c/m*)
		Wattage (W)	
1		21 – 23	Light stays on
2		42 – 46	75 – 95

* : Cycle(s) per minute

Testing Turn Signal Relay
(Example: Two lights are connected.)

West German Model

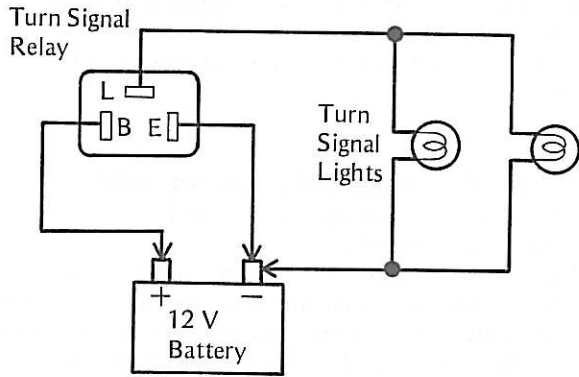

Other than West German Model

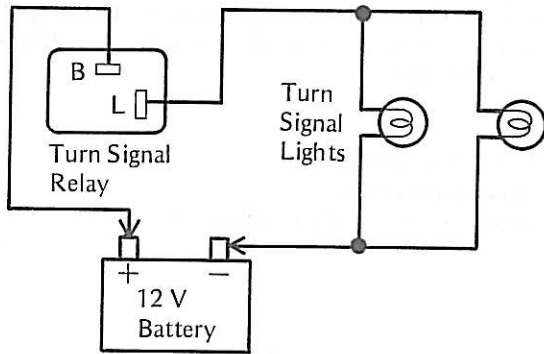

LCD Gauge and Warning System

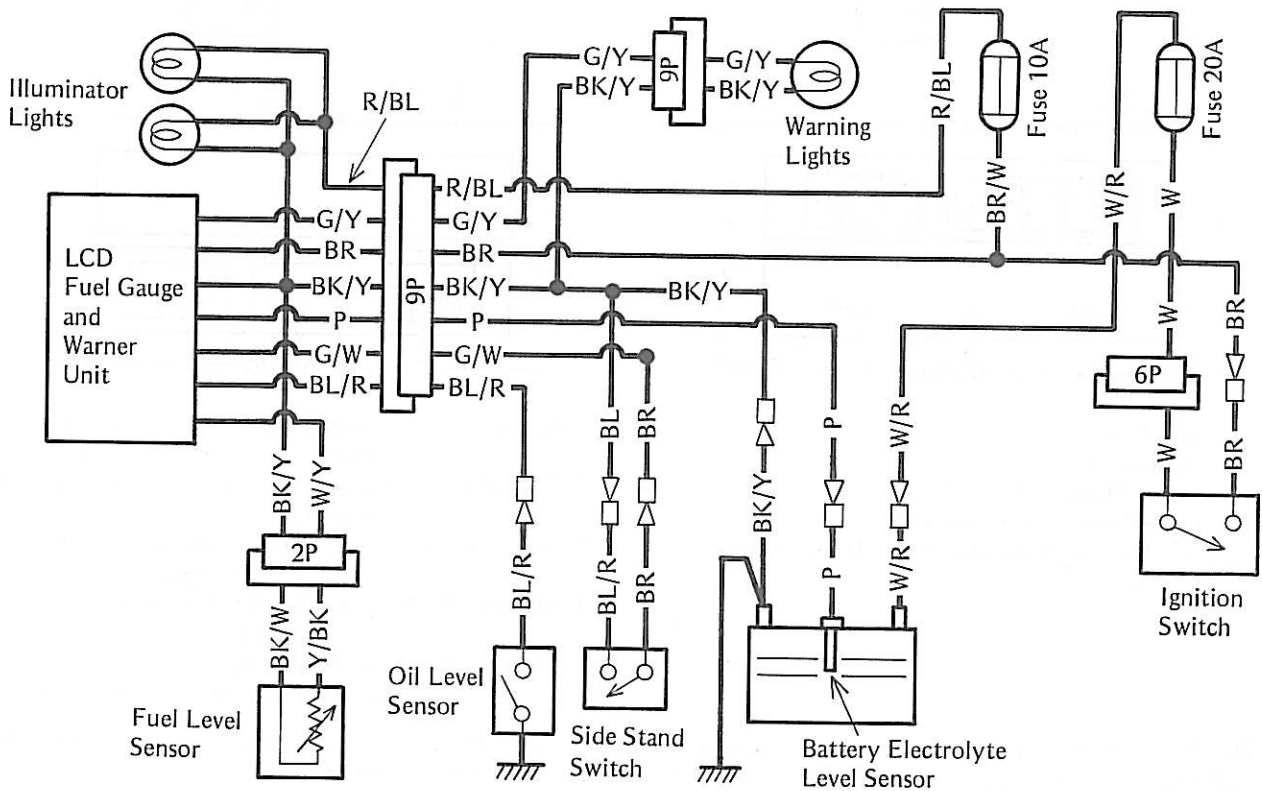

LCD Fuel Gauge and Warner Unit (ZX550)

Outline:

Refer to p. 389 – 390 of the Base Manual, noting the following.

- The warning light is separated from the LCD unit and built in the indicator panel.
- Warning Light: This red warning light flashes when any one of the LCD warners flashes.

Gauge and Warning System Troubleshooting:

Refer to p. 390 of the Base Manual, noting the following.

Test No. 1 – Quick Initial Check

Refer to p. 390 of the Base Manual.

Test No. 2 – Power Supply Test

Refer to p. 390 of the Base Manual.

Test No. 3 – Gauge and Warner Unit Test

- Prepare seven auxiliary wires, two to supply battery power to the unit, four to simulate the sensors, and one to connect to the warning light.
- Remove the gauge and warner unit from the fuel tank.
- Connect one wire between the green/yellow wires in the male unit connector and female main harness connector.
- Connect the four sensor simulating wires to the terminals in the unit connectors.

9-32 SUPPLEMENT—1984 MODEL

Sensor Simulating Wire Connections

Circuit	Connections
Side Stand Warner	○Green/white lead → Battery (-)
Oil Level Warner	○Blue/red lead → Battery (-)
Battery Electrolyte Level Warner	○Pink lead → Battery (+)
Fuel Gauge and Warner	○White/yellow lead → Battery (-)

- Using the wires to supply battery power to the unit, connect the brown terminal in the connector with the battery positive (+) terminal and connect the black/yellow terminal in the connector with the battery negative (-) terminal.

CAUTION

- Take care not to short the wires to the chassis ground.

When the unit is connected to the battery, the self-checking procedure should start. After the procedure is completed, the gauge and warner display should be as shown in the figure (a). If the self-checking procedure did not start, or if there is any fault on the display; replace the gauge and warner unit.

Gauge and Warner Unit Test

(a) All sensor simulating wires are connected.

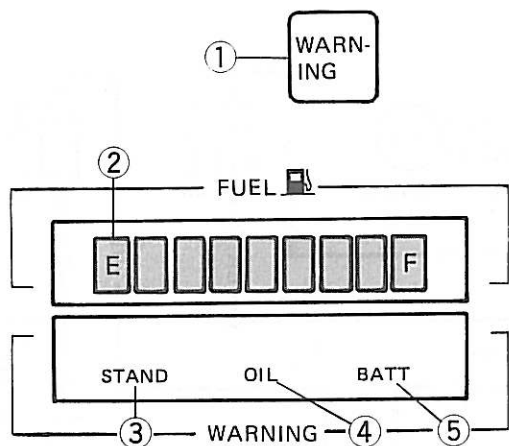

- Warning Light: Unlits.
- Fuel Gauge: Nine segments appear.
- Side Stand Warner: Does not appear.
- Oil Level Warner: Does not appear.
- Battery Electrolyte Level Warner: Does not appear.

- Disconnect one of the sensor simulating wires from the connector.

If both the LCD warner and the red warning light flash as shown in the figure (b), the unit works properly. Proceed to the "Test No. 4 - Wiring and Connector Test". If any of them does not flash, or if any of them stays on without flashing, replace the gauge and warner unit.

Test No. 4 - Wiring and Connector Test

- Set the motorcycle on the center stand.
- Remove the fuel tank.
- Connect the multimeter to the wire in the disconnected female connector (main wiring harness side connector) as indicated in the table and read the meter. When checking the wiring for the fuel gauge and low fuel warner, disconnect the fuel level sensor connector.
- If the multimeter does not read as shown in the table, first inspect the related wire(s) and connector(s), then repair or replace the damaged part(s). If the wire(s) and connector(s) prove good, proceed to the "Test No. 5 - Sensor Test".

Test No. 5 - Sensor Test

(a) Side Stand Switch:

Refer to p. 392 of the Base Manual.

(b) Sensor simulating wires are disconnected.

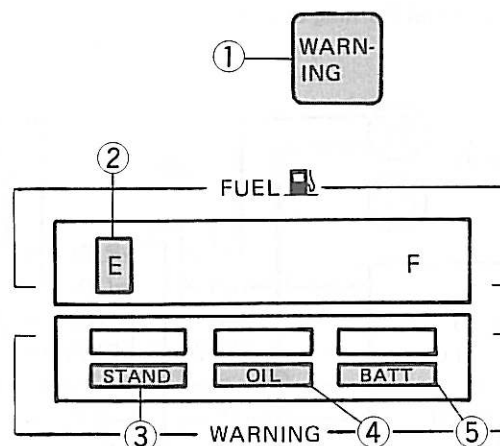

- Warning Light: Flashes when any one of simulating wires is disconnected.
- Fuel Warner: Flashes when white/yellow wire is disconnected.
- Side Stand Warner: Flashes when green/white wire is disconnected.
- Oil Level Warner: Flashes when blue/red wire is disconnected.
- Battery Electrolyte Level Warner: Flashes when pink wire is disconnected.

The time delay circuit is provided in the fuel gauge circuit to stabilize the gauge display. It takes 3 to 12 seconds for each segment to disappear or appear. Also it takes 3 to 7 seconds for the bottom segment to begin or stop flashing.

(b) Oil Level Sensor:

Refer to p. 392 of the Base Manual.

(c) Electrolyte Level Sensor:

Refer to p. 392 – 393 of the Base Manual.

(d) Fuel Level Sensor:

Refer to p. 334 of the Base Manual.

Wiring and Connector Test

Wire	Meter Range	Meter Connections	Meter Reading (Criteria)
Side stand warner	$\times 1 \Omega$	<ul style="list-style-type: none"> ○ One meter lead → Green/white wire ○ Other meter lead → Black/yellow wire 	<ul style="list-style-type: none"> ○ 0Ω when side stand is up. ○ $\infty \Omega$ when side stand is down.
Oil level warner	$\times 10 \Omega$	<ul style="list-style-type: none"> ○ One meter lead → Blue/red wire ○ Other meter lead → Black/yellow wire 	<ul style="list-style-type: none"> ○ Less than 0.5Ω when engine oil level is higher than "lower level line" next to the oil level gauge. ○ $\infty \Omega$ when engine oil level is much lower than the "lower level line".
Battery electrolyte level warner	10 V DC	<ul style="list-style-type: none"> ○ Meter (+) → Pink wire ○ Meter (-) → Black/yellow wire 	<ul style="list-style-type: none"> ○ More than 6 V when electrolyte level is higher than "lower level line". ○ 0 V when electrolyte level is lower than "lower level line".
Fuel gauge and low fuel warner	$\times 10 \Omega$	<ul style="list-style-type: none"> ○ One meter lead → Yellow/black wire ○ Other meter lead → Black/white wire 	<ul style="list-style-type: none"> ○ 1 – 117 Ω

Disassembly

Evaporative Emission Control System (US California Vehicle only)

WARNING

Gasoline is extremely flammable and can be explosive under certain conditions. Turn the ignition switch OFF. Do not smoke. Make sure the area is well ventilated and free from any source of flame or sparks; this includes an appliance with a pilot light.

CAUTION

If gasoline, solvent, water or any other liquid enters the canister, canister's vapor absorbing capacity is greatly reduced, and there is no way to recover it to the original level. In that case, replace the canister with a new one.

Removal and Installation Points

- To prevent the gasoline from flowing out during the Evaporative Emission Control System servicing, observe the following manners.
- Disconnect the breather hose and return hose off the tank fittings before starting the tank removal, if the gasoline is in the tank.
- Plug the return hose fitting during the tank removal and installation, if the gasoline is in the tank.
- Hold the separator perpendicular to the ground.
- Connect the hoses referring to the figure of the system.

Evaporative Emission Control Parts

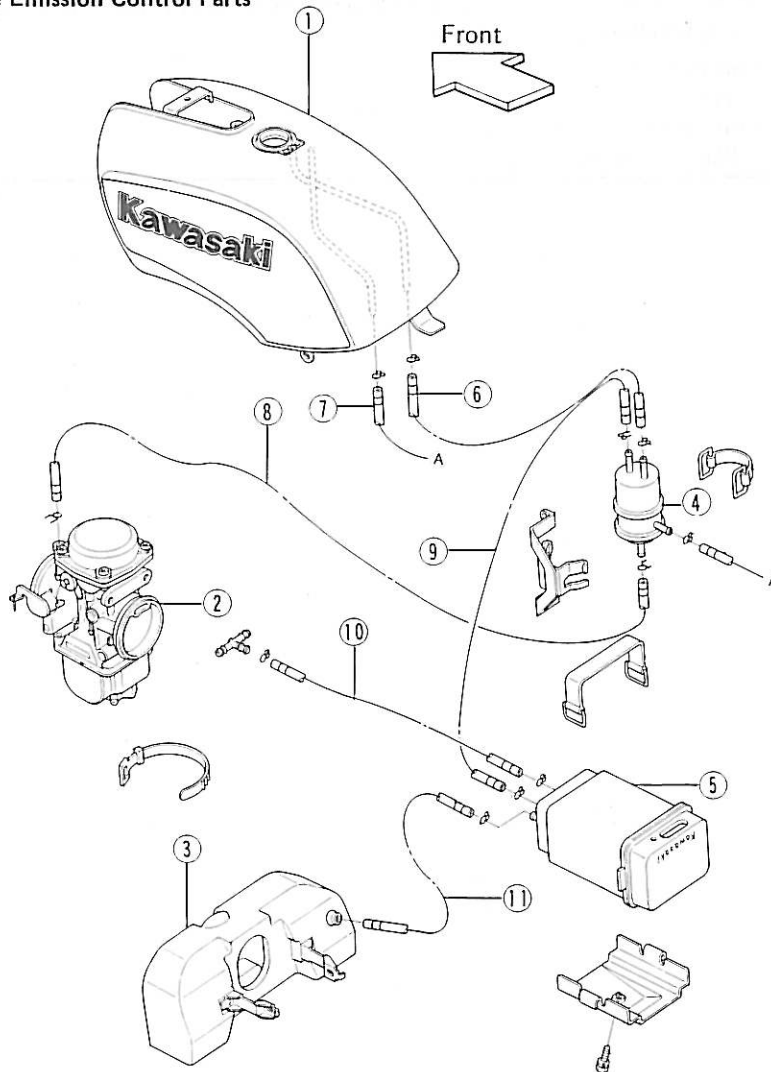

1. Fuel Tank
2. Carburetor
3. Air Cleaner
4. Liquid/Vapor Separator
5. Canister
6. Breather Hose (Blue)
7. Fuel Return Hose (Red)
8. Vacuum Hose (White)
9. Breather Hose (Blue)
10. Breather Hose (Yellow)
11. Parge Hose (Green)

.....
Camshafts (ZX550)
Camshaft Sprockets (ZX550)

- Refer to the Base Manual, noting the following.
- To set the camshaft chain timing, use the procedure of the KZ400's. See p. 271 of the Base Manual.
 - To install the camshaft sprockets to the camshafts, use the procedure of the KZ400's. See p. 271 of the Base Manual.

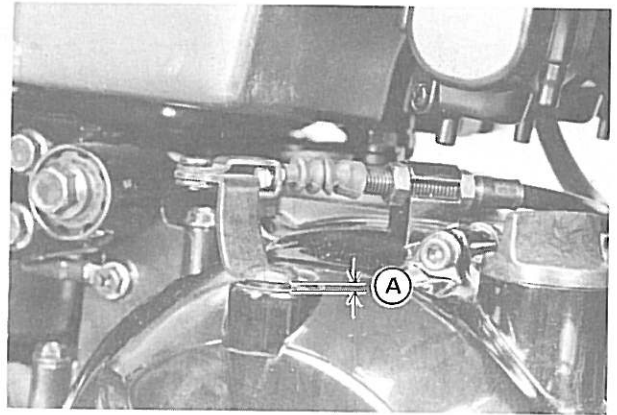

A. 2 – 3 mm

.....
Cylinder Block

- Refer to p. 64 – p. 66 of the Base Manual, noting the following.
- Apply a thin coat of a molybdenum disulfide engine assembly grease to the front and rear skirts of the #1, #4 pistons.

.....
Crankcase Split

- Refer to p. 96 – p. 104 of the Base Manual, noting the following.
- Apply a liquid gasket to the mating surface of the upper and lower crankcase halves indicated in the figure.

CAUTION

- Take care not to block or obstruct the oil passages with liquid gasket. This could cause engine seizure.

.....
Clutch Release (ZX550)
Clutch (ZX550)

- Refer to p. 78 – p. 80 of the Base Manual, noting the following.
- Turn the clutch release lever counterclockwise, and pull the release shaft out the clutch cover.
 - When installing the release shaft, check and see that the clutch release is installed on the clutch cover with proper angle (about 80°) and clearance between the clutch release lever and the top of the clutch cover when the clutch release lever is fully turned clockwise.

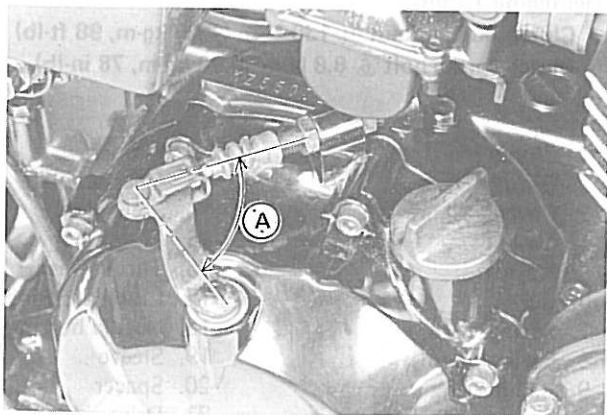

A. About 80°

Liquid Gasket Applied Area

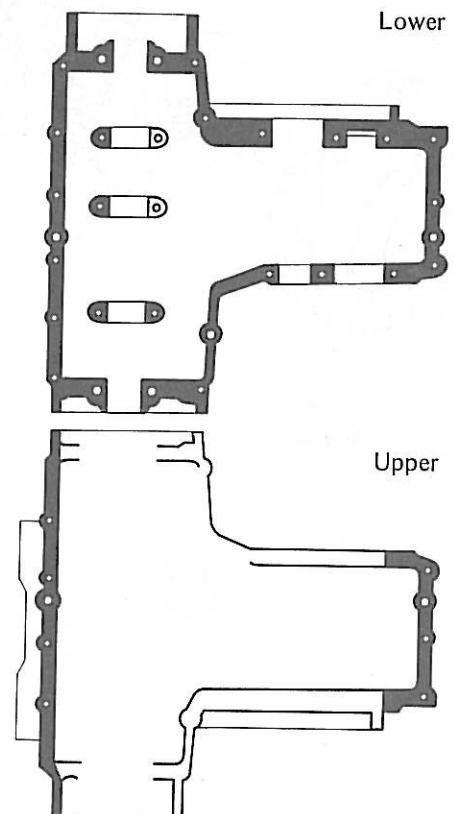

Clutch

682134

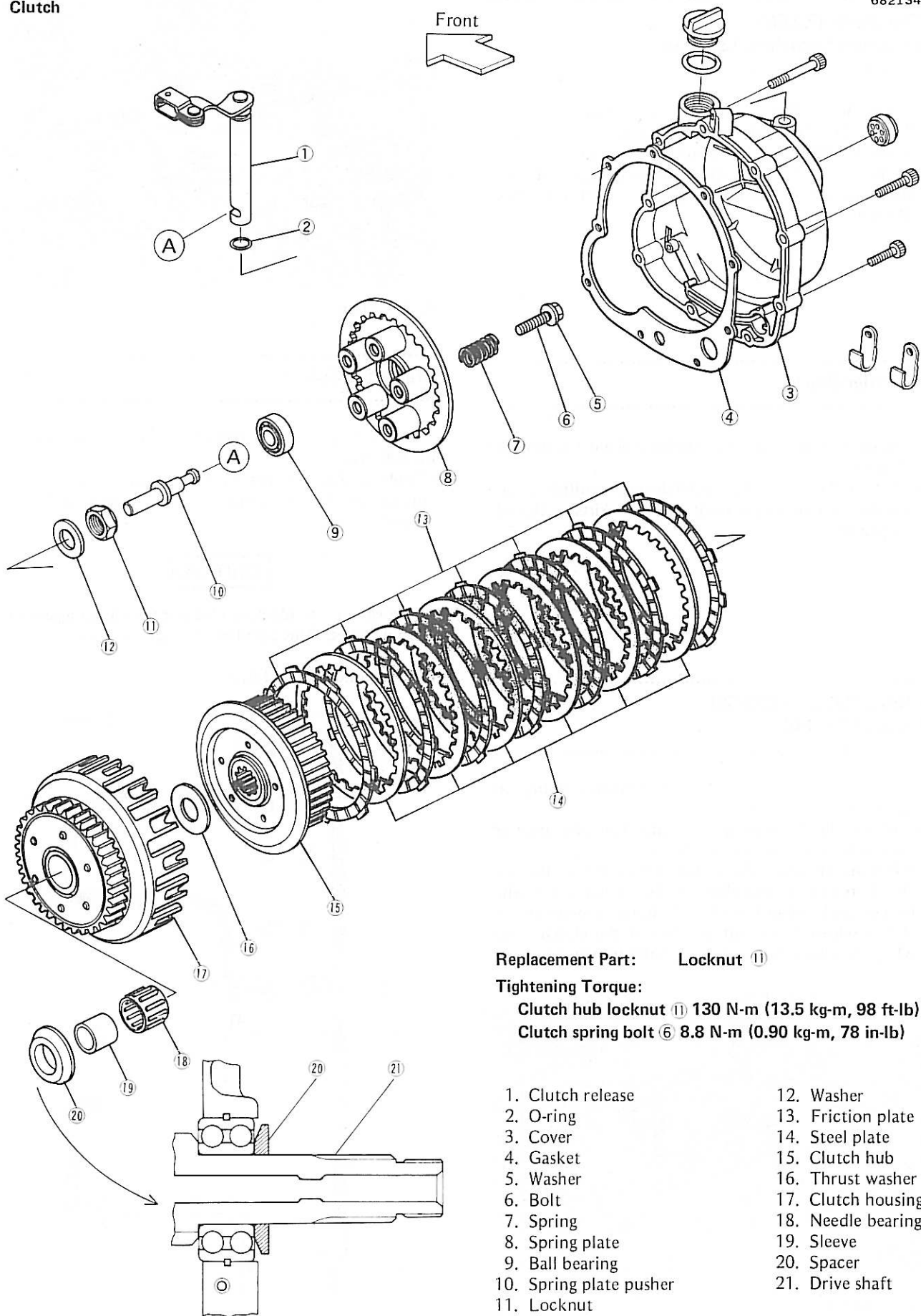
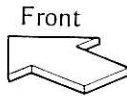

Replacement Part: Locknut ⑪

Tightening Torque:

Clutch hub locknut ⑪ 130 N-m (13.5 kg-m, 98 ft-lb)

Clutch spring bolt ⑥ 8.8 N-m (0.90 kg-m, 78 in-lb)

- | | |
|-------------------------|--------------------|
| 1. Clutch release | 12. Washer |
| 2. O-ring | 13. Friction plate |
| 3. Cover | 14. Steel plate |
| 4. Gasket | 15. Clutch hub |
| 5. Washer | 16. Thrust washer |
| 6. Bolt | 17. Clutch housing |
| 7. Spring | 18. Needle bearing |
| 8. Spring plate | 19. Sleeve |
| 9. Ball bearing | 20. Spacer |
| 10. Spring plate pusher | 21. Drive shaft |
| 11. Locknut | |

Bearing Insert Selection

**Bearing Insert Size Mark Location
(both con-rod and main)**

682150

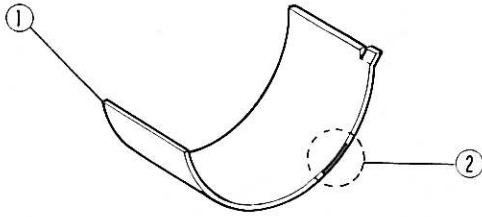

- 1. Bearing insert
- 2. Color size mark

Big End Bore Diameter Mark Location

682151

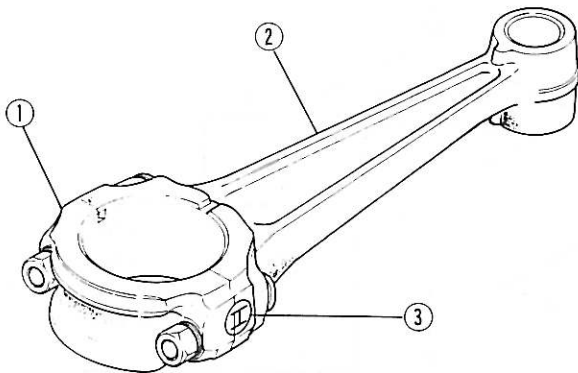

- 1. Big end cap
- 2. Connecting rod
- 3. Diameter mark
o mark or no mark, around
weight mark alphabet

**Main Bearing Bore Diameter Marks
on Upper Crankcase Half**

682152

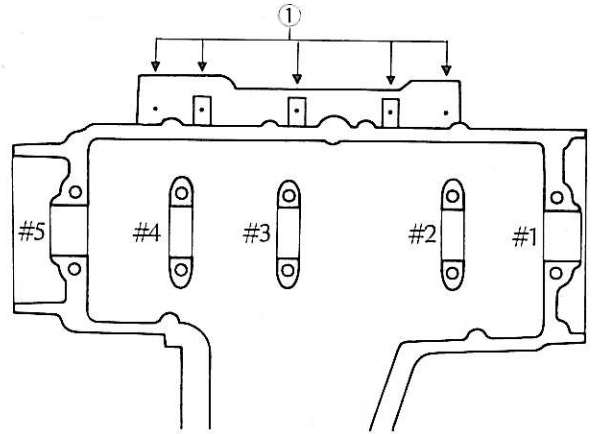

- 1. Diameter mark,
1 mark or no mark

The main bearing bore diameter marks are engraved on areas called out by numbers 1 through 5. Each number shows main bearing number (numbering method, left to right).

Crankshaft Mark Locations

682153

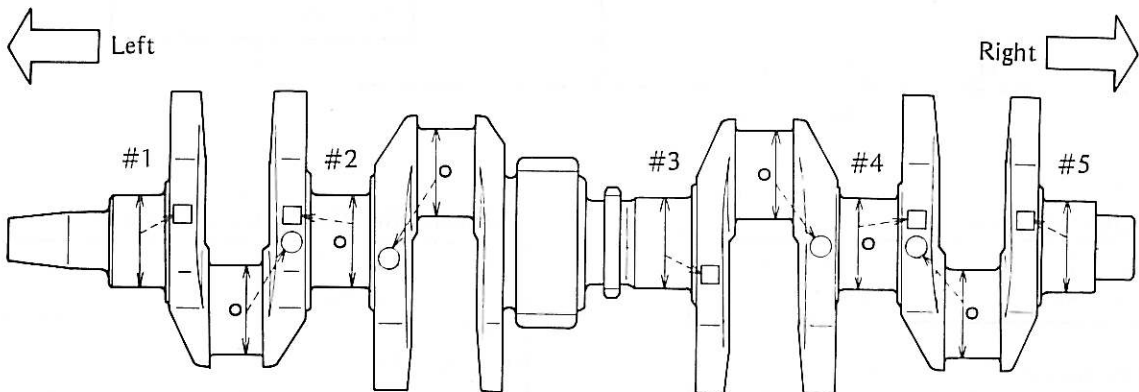

- : Crankpin diameter locations
- : Main journal diameter locations

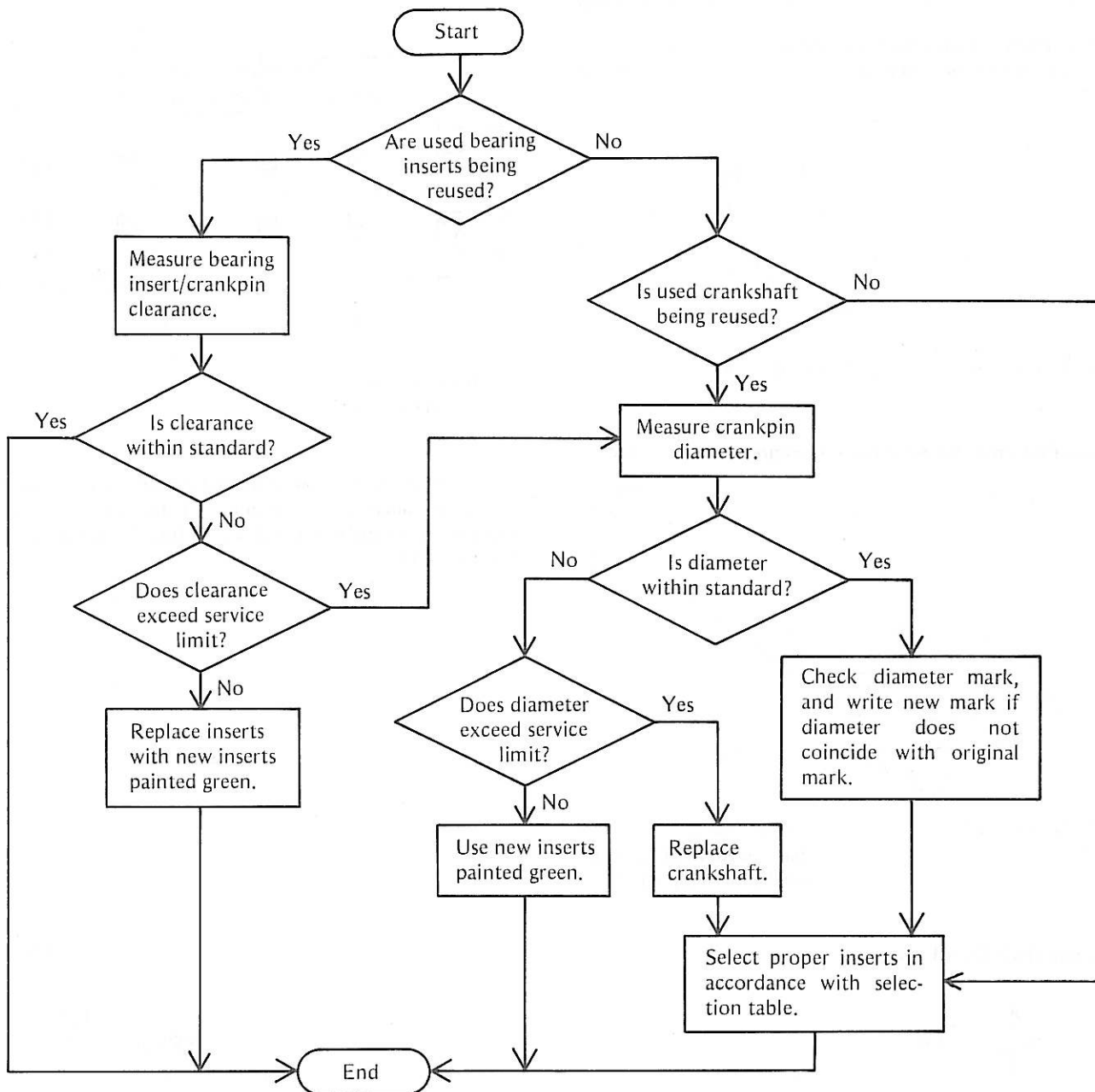

Bearing Insert/Crankpin Clearance

Standard:	0.031 – 0.059 mm
Service limit:	0.10 mm

Crankpin Diameter

Standard:	32.984 – 33.000 mm
Service limit:	32.97 mm

Crankpin Diameter Marks

No mark:	32.984 – 32.994 mm
○ :	32.994 – 33.000 mm

Connecting Rod Bearing Insert Selection

	Con-Rod Marking	○	No mark
Crankshaft Marking		○	No mark
	○	Black P/N:13034-1005	Brown P/N:13034-1006
	No mark	Green P/N:13034-1004	Black P/N:13034-1005

Crankshaft Main Bearing Insert Selection:

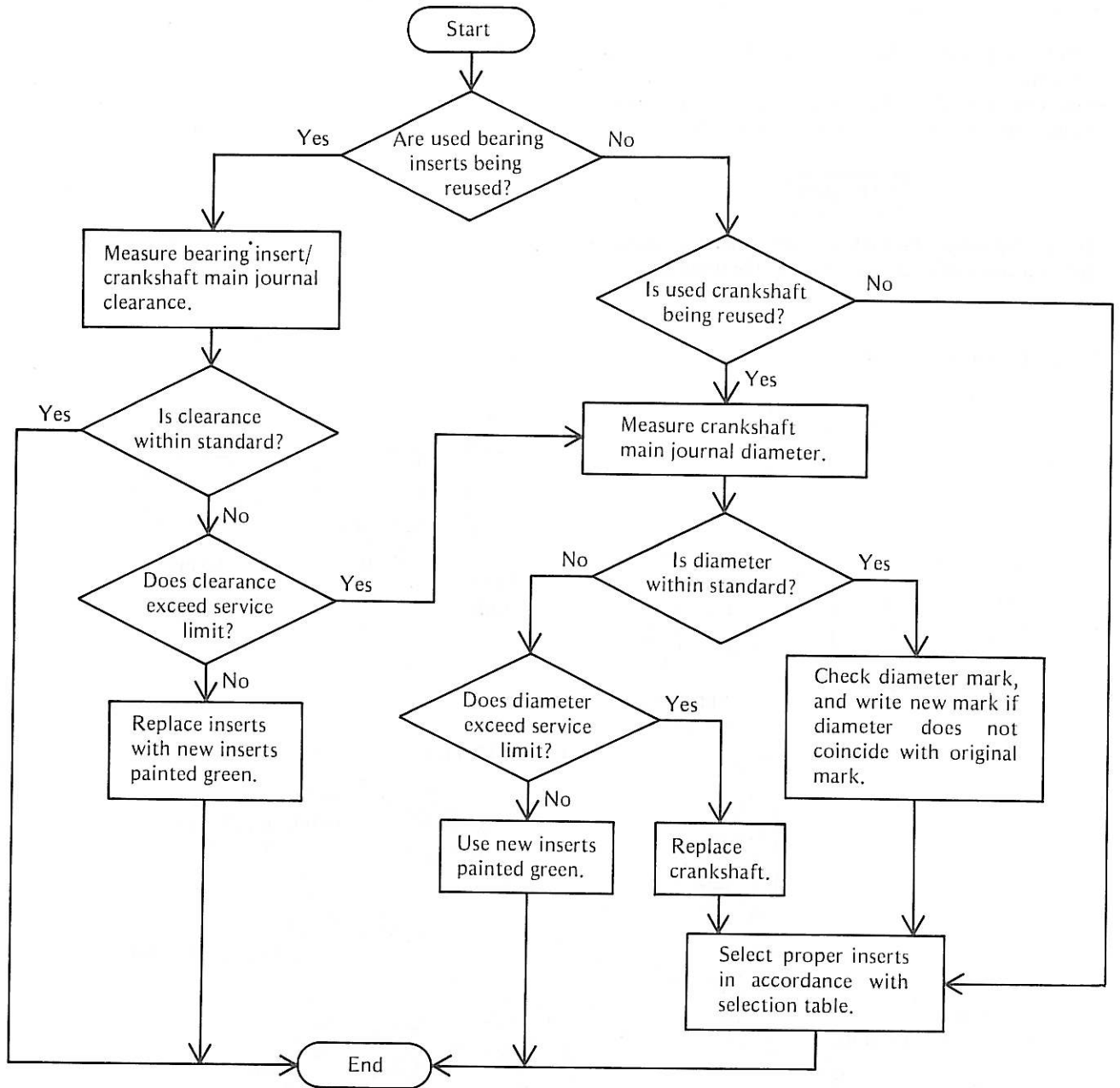

Bearing Insert/Crankshaft Main Journal Clearance

Standard	0.014 – 0.038 mm
Service limit:	0.08 mm

Crankshaft Main Journal Diameter

Standard:	31.984 – 32.000 mm
Service limit:	31.96 mm

Crankshaft Main Journal Diameter Marks

No mark:	31.984 – 31.992 mm
1	31.992 – 32.000 mm

Main Bearing Insert Selection

	Crankcase Marking	○	No mark
Crankshaft Marking			
1		Brown P/N:13034-1016	Black P/N:13034-1017
No mark		Black P/N:13034-1017	Green P/N:13034-1018

9-40 SUPPLEMENT-1984 MODEL

Engine Removal (ZX550)

Refer to p. 335 – 336 of the Base Manual, noting the following.

- Lubricate the rubber damper surfaces with a soap and water solution, and press them into brackets.

CAUTION

- Do not lubricate the rubbers with mineral oil because this will cause early deterioration of the rubbers.

Engine Mounting

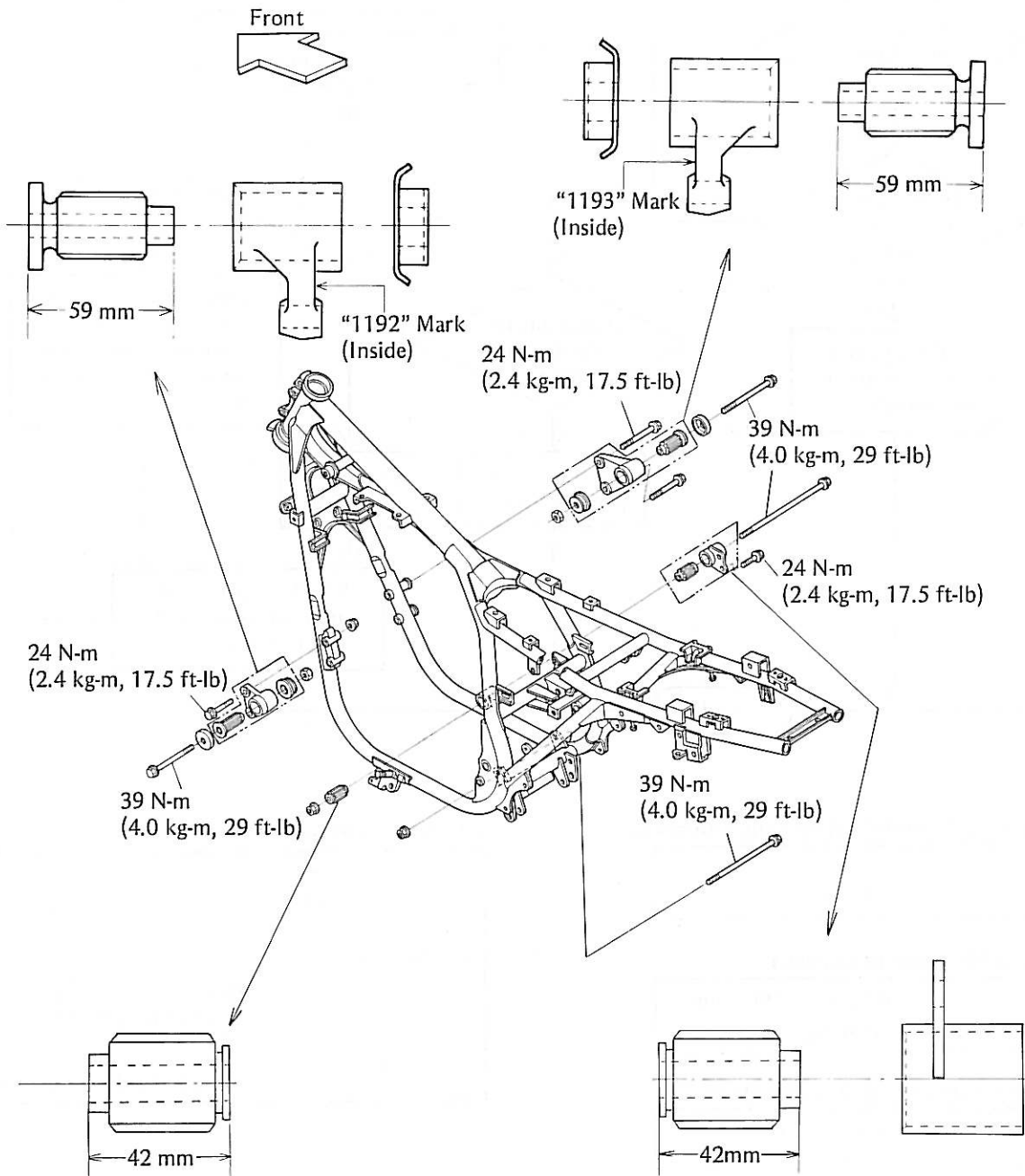

Brakes (ZX550)

Refer to p. 7-2, noting the following.

Rear Master Cylinder and Rear Caliper

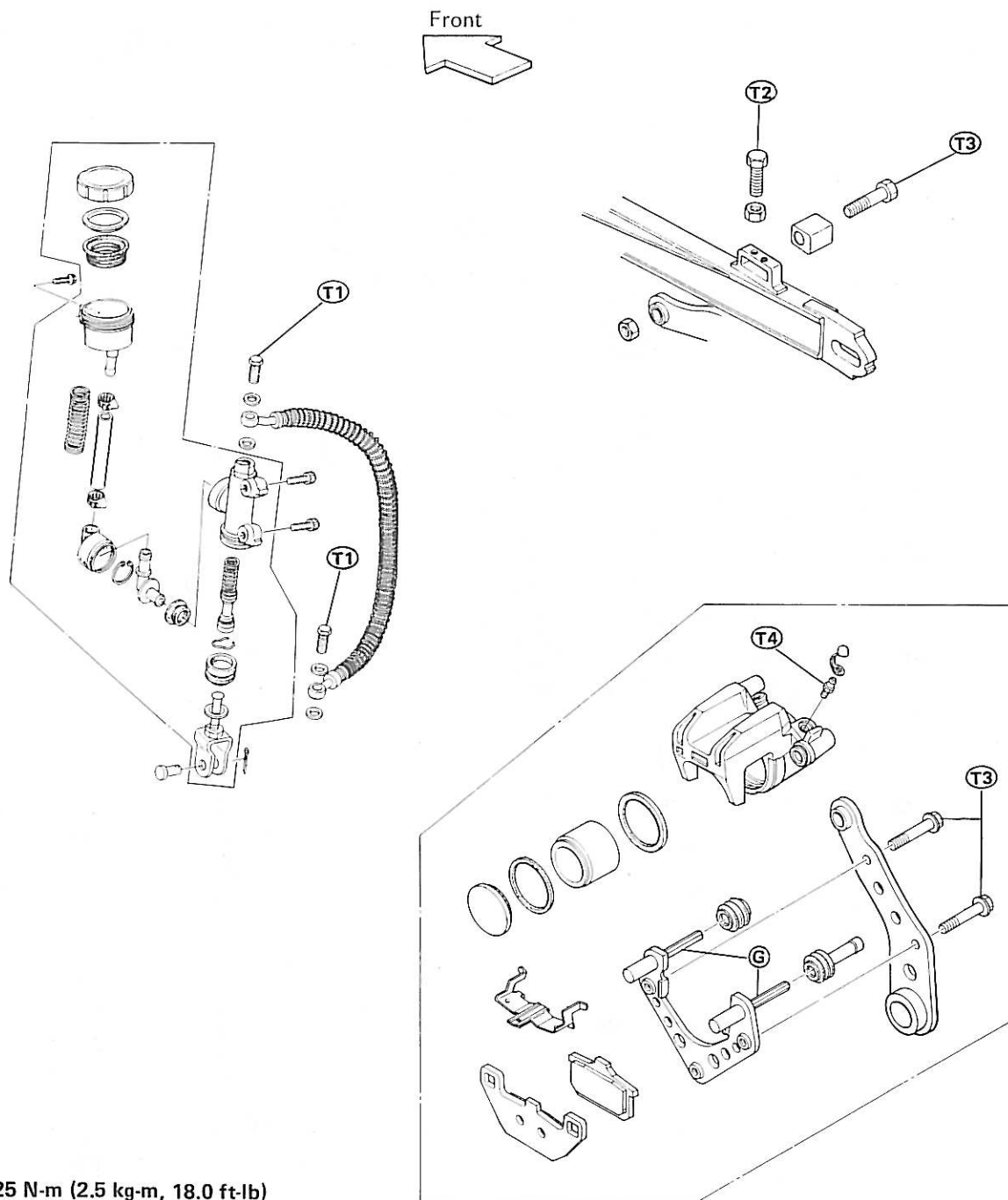

- Ⓣ1 25 N-m (2.5 kg-m, 18.0 ft-lb)
- Ⓣ2 6.4 N-m (0.65 kg-m, 56 in-lb)
- Ⓣ3 32 N-m (3.3 kg-m, 24 ft-lb)
- Ⓣ4 7.8 N-m (0.80 kg-m, 69 in-lb)
- ⓖ PBC* Grease

* : PBC grease is a special high temperature, water-resistant grease.

9-42 SUPPLEMENT—1984 MODEL

Front Fork (ZX550)

Refer to p. 368 – 369 of the Base Manual, noting the following.

Front Fork and Anti-Dive Unit

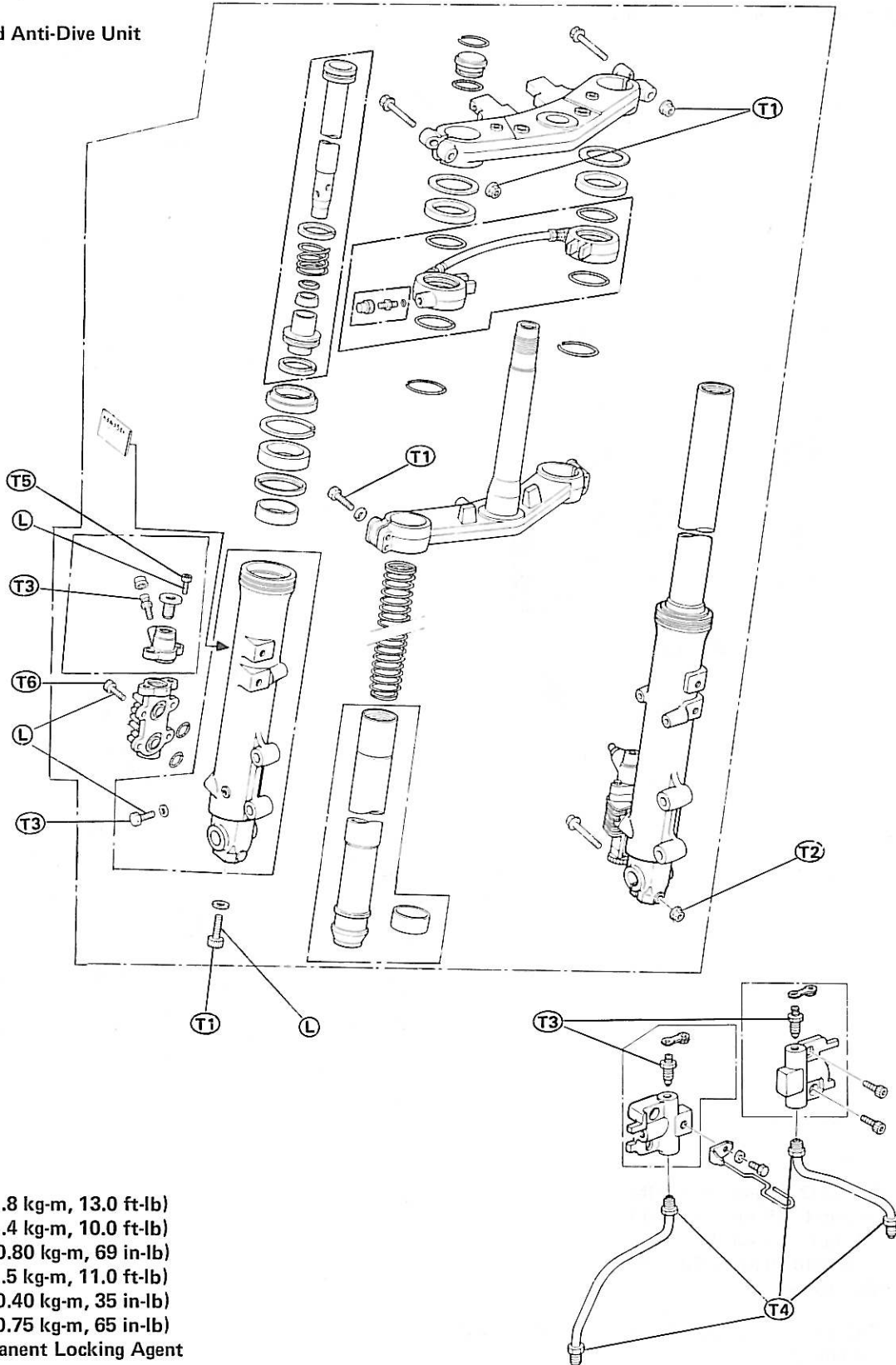
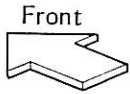

- T1 18 N-m (1.8 kg-m, 13.0 ft-lb)
- T2 14 N-m (1.4 kg-m, 10.0 ft-lb)
- T3 7.8 N-m (0.80 kg-m, 69 in-lb)
- T4 15 N-m (1.5 kg-m, 11.0 ft-lb)
- T5 3.9 N-m (0.40 kg-m, 35 in-lb)
- T6 7.4 N-m (0.75 kg-m, 65 in-lb)
- L Non-permanent Locking Agent

.....
Swing Arm (ZX550)
Uni-Trak Links (ZX550)
Rear Shock Absorber (ZX550)
.....

Rear Shock Absorber, Uni-Trak Links and Swing Arm

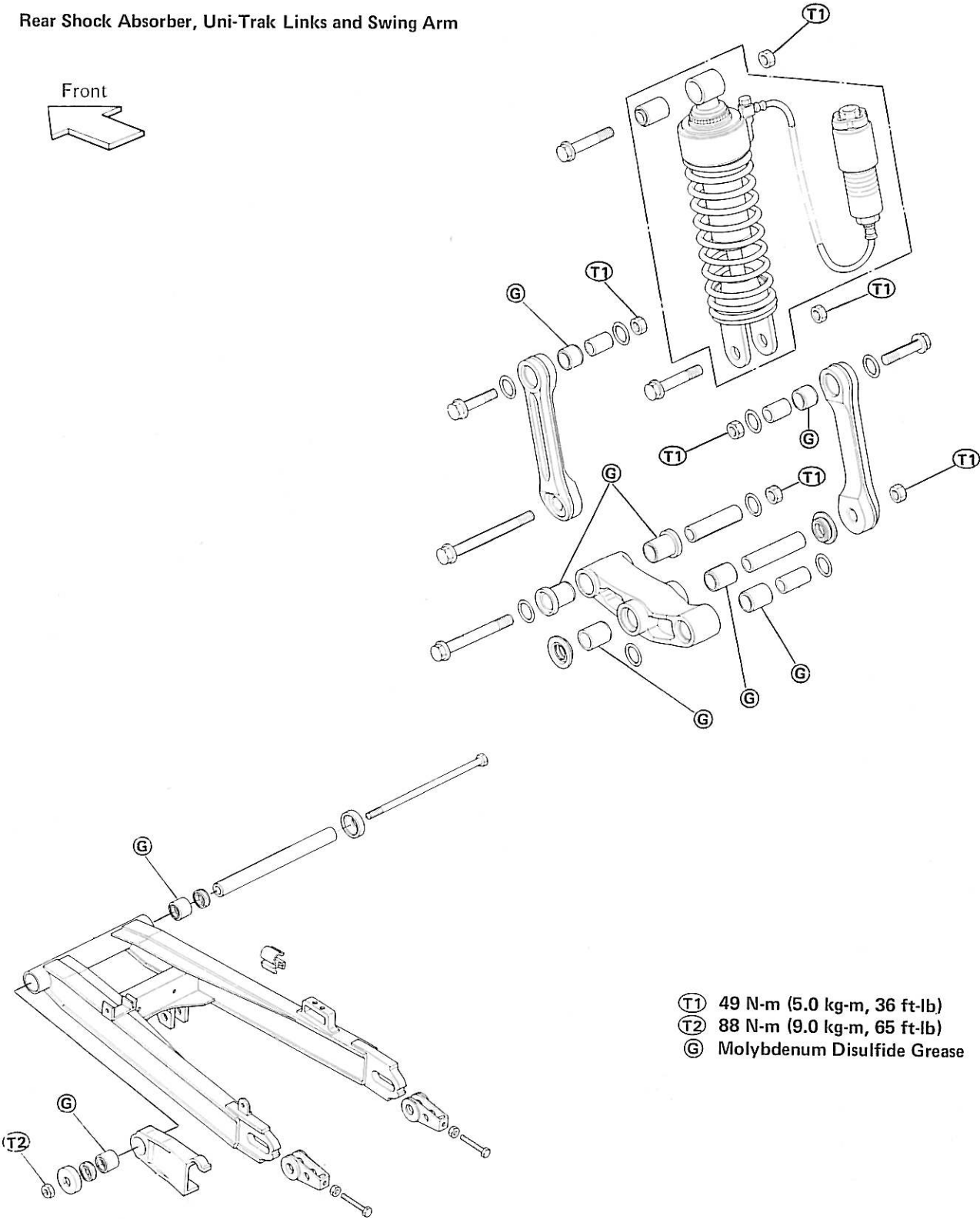
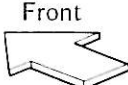

- (T1) 49 N-m (5.0 kg-m, 36 ft-lb)
- (T2) 88 N-m (9.0 kg-m, 65 ft-lb)
- (G) Molybdenum Disulfide Grease

Supplement – 1985 Model

This chapter, "Supplement—1985 Model", is designed to be used in conjunction with the front part of this manual (up to the end of the chapter 9). The maintenance and repair procedures described in this chapter are only those that are unique to the 1985 model. Complete and proper servicing of the 1985 model therefore requires mechanics to read both this chapter and the front part of this manual (up to the end of the chapter 9).

NOTE

- *The service procedures for the 1985 model ZX400A and ZX400C are newly included in this section. Unless otherwise noted, refer to the description for the following 1984 model.*
ZX550-A1 for ZX400-A3 and ZX400-C2

Table of Contents

General Information

Model Identification	10-2
Specifications (ZX400)	10-3
Service Data (ZX400)	10-5
Setting Before Ride (ZX400)	10-7
ZX400-C2 Wiring Diagram	10-8

Non-scheduled Maintenance

LCD Fuel Gauge and Warner Unit (ZX400C)	10-9
---	------

Disassembly

Clutch Release	10-11
Brakes (ZX400)	10-11

General Information

.....
Model Identification
.....

ZX550-A2/ZX400-A3:

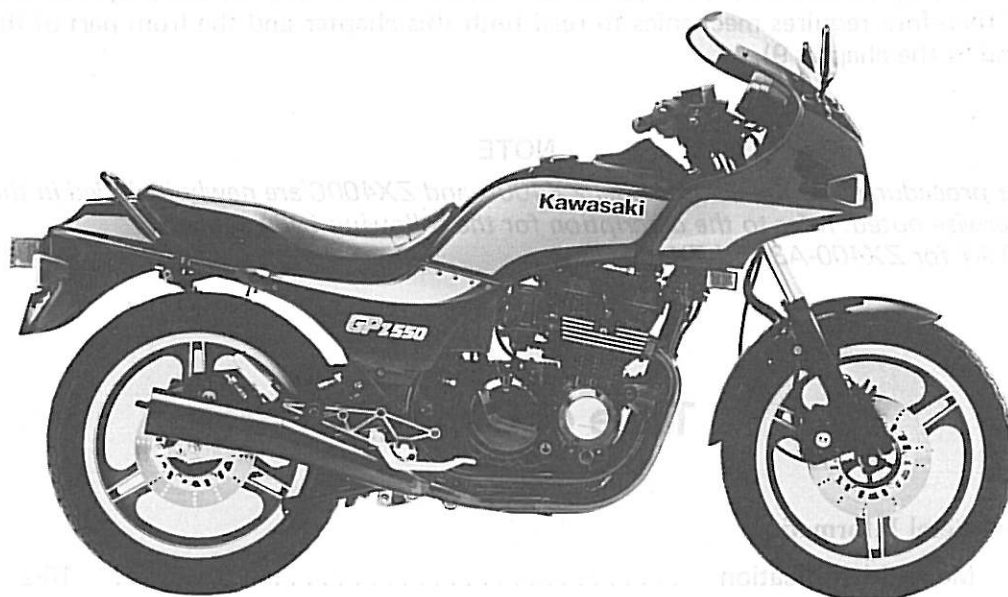

ZX400-C2:

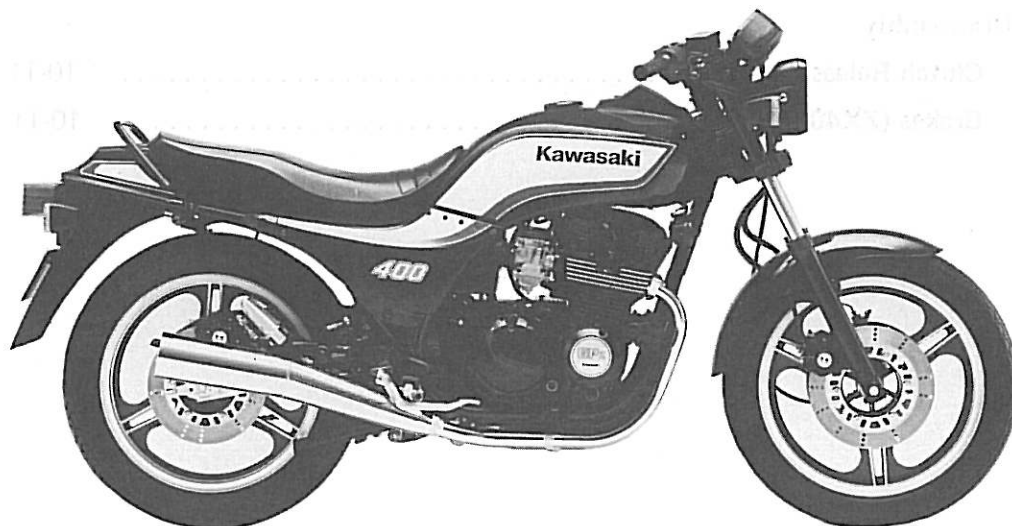

.....
Specifications (ZX400)

Items	ZX400-A3	ZX400-C2
Dimensions:		
Overall length	2 180 mm	*
Overall width	720 mm	*
Overall height	1 245 mm	1 145 mm
Wheelbase	1 435 mm	*
Road clearance	160 mm	*
Seat height	780 mm	*
Dry weight	1 800 N (184 kg)	1 760 N (179 kg)
Curb weight: Front	981 N (100 kg)	951 N (97 kg)
Rear	1 000 N (102 kg)	1 010 N (103 kg)
Fuel tank capacity	18.0 L	*
Performance:		
Climbing ability	30°	*
Braking distance	12.5 m from 50 km/h	*
Minimum turning radius	2.5 m	*
Engine:		
Type	4-stroke, DOHC, 4-cylinder	*
Cooling system	Air cooled	*
Bore and stroke	55.0 x 42.0 mm	*
Displacement	399 mL	*
Compression ratio	9.7	*
Maximum horsepower	Ⓜ 20 kW (27 PS) @10 000 r/min (rpm)	40 kW (54 PS) @ 11 500 r/min (rpm)
Maximum torque	Ⓜ 25 N-m (2.6 kg-m, 19 ft-lb) @4 000 r/min (rpm)	34 N-m (3.5 kg-m, 25 ft-lb) @9 500 r/min (rpm)
Carburetion system	Carburetors, Keihin CV30 x 4	*
Starting system	Electric starter	*
Ignition system	Battery and coil (transistorized)	*
Timing advance	Electronically advanced	*
Ignition timing	From 15° BTDC @1 200 r/min (rpm) to 40° BTDC @7 000 r/min (rpm)	*
Spark Plug	NGK DPR9EA-9 or ND X27EPR-U9	NGK DPR9EA-9 or ND X27EPR-U9 ① NGK DP9EA-9 or ND X27EP-U9
Cylinder numbering method	Left to right, 1-2-3-4	*
Firing order	1-2-4-3	*
Valve timing: Inlet	Open	46° BTDC
	Close	54° ABDC
	Duration	280°
Exhaust	Open	64° BBDC
	Close	36° ATDC
	Duration	280°

(Continued on next page.)

10-4 SUPPLEMENT—1985 MODEL

Items	ZX400-A3	ZX400-C2
Lubrication system	Forced lubrication (wet sump)	*
Engine Oil: Grade	SE or SF class	*
Viscosity	SAE 10W40, 10W50, 20W40, or 20W50	*
Capacity	3.0 L	*
Drive Train:		
Primary reduction system:		
Type	Gear and chain	*
Reduction ratio	3.277 (27/23 x 67/24)	*
Clutch type	Wet multi disc	*
Transmission: Type	6-speed, constant mesh, return shift	*
Gear ratios: 1st	2.571 (36/14)	*
2nd	1.777 (32/18)	*
3rd	1.380 (29/21)	*
4th	1.125 (27/24)	*
5th	0.961 (25/26)	*
6th	0.851 (23/27)	*
Final drive system: Type	Chain drive	*
Reduction ratio	2.625 (42/16)	*
Overall drive ratio	7.328 @Top gear	*
Frame:		
Type	Tubular, double cradle	*
Castor (rake angle)	25.5°	*
Trail	93 mm	*
Front tire: Type	Tubeless	*
Size	100/90-18 56H	*
Rear tire: Type	Tubeless	*
Size	110/90-18 61H	*
Front suspension: Type	Telescopic fork (pneumatic)	*
Wheel travel	160 mm	*
Rear suspension: Type	Swing arm (uni-trak)	*
Wheel travel	130 mm	*
Brake type: Front	Dual disc	*
Rear	Single disc	*
Electrical Equipment:		
Battery	12 V 10 Ah	*
Headlight: Type	Semi-sealed beam	*
Bulb	12 V 60/55 W (quartz-halogen)	*
Tail/brake light	12 V 5/21 W x 2	*
Alternator: Type	Three-phase AC	*
Rated output	18.5 A @10 000 r/min (rpm), 14 V	*
Voltage regulator: Type	Short-circuit	*

Specifications subject to change without notice, and may not apply to every country.

* : Same as ZX400-A3

Ⓘ Italian Model

Ⓜ West German Model

10-6 SUPPLEMENT—1985 MODEL

Item	Standard	Service Limit	See Page														
Wheels: Standard tires: Front Rear Tire air pressure: ZX400A ZX400C Tire Tread Depth: Front Rear	100/90-18 56 H Dunlop F11, Tubeless 110/90-18 61 H Dunlop K427, Tubeless <table border="1"> <tr> <td>Front</td> <td colspan="2">196 kPa (2.0 kg/cm², 28 psi)</td> </tr> <tr> <td>Rear</td> <td>Up to 1 790 N (183 kg) load</td> <td>221 kPa (2.25 kg/cm², 32 psi)</td> </tr> </table> <table border="1"> <tr> <td>Front</td> <td colspan="2">196 kPa (2.0 kg/cm², 28 psi)</td> </tr> <tr> <td rowspan="2">Rear</td> <td>Up to 956 N (97.5 kg) load</td> <td>221 kPa (2.25 kg/cm², 32 psi)</td> </tr> <tr> <td>956 – 1 810 N (97.5 – 185 kg) load</td> <td>245 kPa (2.50 kg/cm², 36 psi)</td> </tr> </table> 4.4 mm 7.2 mm	Front	196 kPa (2.0 kg/cm ² , 28 psi)		Rear	Up to 1 790 N (183 kg) load	221 kPa (2.25 kg/cm ² , 32 psi)	Front	196 kPa (2.0 kg/cm ² , 28 psi)		Rear	Up to 956 N (97.5 kg) load	221 kPa (2.25 kg/cm ² , 32 psi)	956 – 1 810 N (97.5 – 185 kg) load	245 kPa (2.50 kg/cm ² , 36 psi)	1 mm 2 mm	p. 1-9 p. 2-21
Front	196 kPa (2.0 kg/cm ² , 28 psi)																
Rear	Up to 1 790 N (183 kg) load	221 kPa (2.25 kg/cm ² , 32 psi)															
Front	196 kPa (2.0 kg/cm ² , 28 psi)																
Rear	Up to 956 N (97.5 kg) load	221 kPa (2.25 kg/cm ² , 32 psi)															
	956 – 1 810 N (97.5 – 185 kg) load	245 kPa (2.50 kg/cm ² , 36 psi)															
Brakes: Disc thickness: Front Rear Pad lining thickness: Front Rear Brake pedal position	3.8 – 4.1 mm 5.8 – 6.1 mm 4.5 mm 4.85 mm 25 – 30 mm below from top of footpeg	3.5 mm 5.5 mm 1 mm 1 mm	p. 203 p. 2-15 p. 355														
Front Fork: Air pressure Oil viscosity Oil amount: Left Right Oil level (Left and right)	59 – 78 kPa (0.6 – 0.8 kg/cm ² , 8.5 – 11 pis) SAE 5W20 250 ±2.5 mL 220 ±2.5 mL 440 ±2 mm below from top of inner tube (extended, without main spring)		p. 1-9 p. 2-20 p. 2-20 p. 2-20														
Ignition System: Spark plug type: Standard Option (for cold wether and low speed riding) Spark plug gap	NGK DPR9EA-9 or NDX 27EPR-U9 NGK DP9EA-9 or NDX27EP-U9 (Italy) NGK DPR8EA-9 or NDX24EPR-U9 NGK DP8EA-9 or NDX24EP-U9 (Italy) 0.8 – 0.9 mm		p. 2-4 p. 2-4														

NOTE

- Refer to p. xxx (shown in the "See Page" column) of the Base Manual.
- Refer to p. x-xx (shown in the "See Page" column) of this Supplement.

Service Data (ZX400)

Refer to p. 1-12 — p. 1-16, noting the following.

Item	Standard	Service Limit	See Page
Idle Speed:	1 200 ±50 r/min (rpm)		p. 2-8
Carburetors:			
Make, Type	Keihin, CV30		
Main jet	#112		
Main air jet	#180 (#1, 4 Carburetors) #110 (#2, 3 Carburetors)		
Jet needle	N16B (#1, 4 Carburetors) N16C (#2, 3 Carburetors)		
Needle jet	#6 (#1, 4 Carburetors) #6 (#2, 3 Carburetors)		
Pilot jet	#35		
Pilot air jet	#130		
Pilot screw	2½ turns out		
Service fuel level	2.0 mm (above bottom edge of body)		p. 381
Float height	16.5 mm		p. 381
Camshafts:			
Cam height	36.246 — 36.354 mm	36.15 mm	p. 162
Cylinder Head:			
Combustion chamber volume	14.6 — 15.4 mL		p. 165
Cylinders, Pistons:			
Cylinder compression	755 — 1 180 kPa (7.7 — 12.0 kg/cm ² , 109 — 171 psi), and less than 98 kPa (1 kg/cm ² , 14 psi) difference between any two cylinders		p. 171
Cylinder inside diameter	55.000 — 55.012 mm, and less than 0.01 mm difference between any two measurements	55.10 mm, or 0.05 mm difference between any two measurements	p. 172
Piston diameter	54.965 — 54.980 mm		p. 172
Piston ring/groove clearance (Top and 2nd)	0.03 — 0.07 mm		p. 173
Piston ring thickness: Top	0.97 — 0.99 mm		p. 173
2nd	1.17 — 1.19 mm		
Piston ring groove width:			p. 173
Top	1.02 — 1.04 mm		
2nd	1.22 — 1.24 mm		
Oil	2.51 — 1.53 mm		
Piston ring end gap (Top and 2nd)	0.15 — 0.35 mm		p. 174
Clutch:			
Clutch spring free length	30.8 mm		—
Friction plate thickness	2.9 — 3.1 mm		p. 181

(Continued on next page.)

.....
Setting Before Ride (ZX400)
.....

Front Fork:

Refer to p. 9-7, noting the following.

- The anti-dive unit is only mounted on the left fork leg.

Rear Shock Absorber:

Refer to p. 9-7 - p. 9-8, noting the following.

- The recommended setting position of the damping force is 1 for one rider with no accessories.

Non-scheduled Maintenance

.....
**LCD Fuel Gauge and Warner Unit
 (ZX400C)**

Outline:

Refer to p. 389 – p. 390 of the Base Manual, noting the following.

Gauge and Warning System Troubleshooting:

Refer to p. 390 – p. 393 of the Base Manual, noting the following.

Test No. 1 – Quick Initial Check

Refer to p. 390 of the Base Manual.

Test No. 2 – Power Supply Test

Refer to p. 390 of the Base Manual.

Test No. 3 – Gauge and Warner Unit Test

Refer to p. 390 – p. 391 of the Base Manual, noting the following.

Gauge and Warning System Wiring Diagram

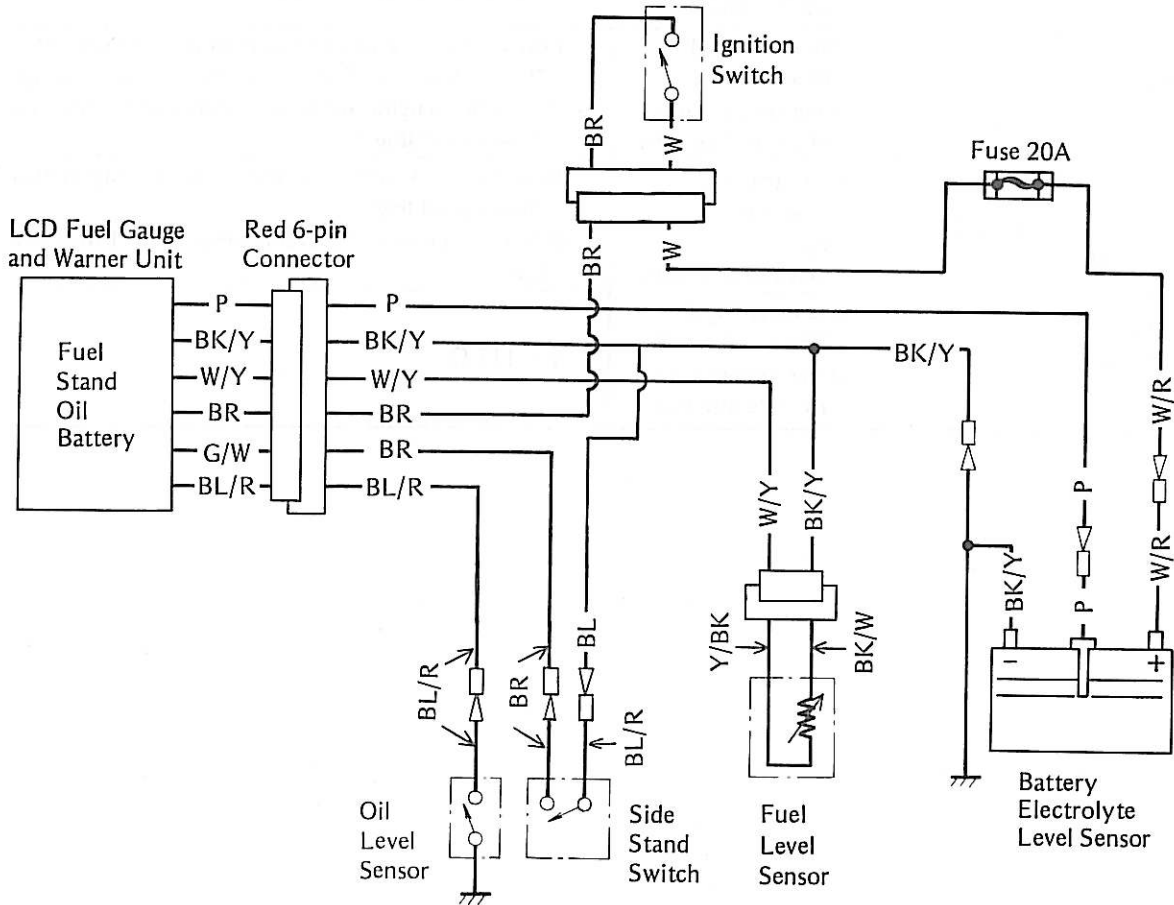

10-10 SUPPLEMENT—1985 MODEL

Sensor Simulating Wire Connections

Circuit	Connections
Side stand warner	○Green/white lead → Battery (-)
Oil level warner	○Blue/red lead → Battery (-)
Battery electrolyte level warner	○Pink lead → Battery (+)
Fuel gauge and low fuel warner	○White/yellow lead → Battery (-)

Test No. 4 — Wiring and Connector Test

Refer to p. 391 — p. 392 of the Base Manual, noting the following.

Test No. 5 — Sensor Test

Refer to p. 392 — p. 393 of the Base Manual.

Wiring and Connector Test

Wire	Meter Range	Meter Connections	Meter Reading (Criteria)
Side stand warner	x 1 Ω	○One meter lead → Brown Wire ○Other meter lead → Black/yellow wire	○0 Ω when side stand is up. ○ ∞ Ω when side stand is down.
Oil level warner	x 10 Ω	○One meter lead → Blue/red wire ○Other meter lead → Black/yellow wire	○Less than 0.5 Ω when engine oil level is higher than "lower level line" next to the oil level gauge. ○ ∞ Ω when engine oil level is much lower than the "lower level line."
Battery electrolyte level warner	10 V DC	○Meter (+) → Pink wire ○Meter (-) → Black/yellow wire	○More than 6 V when electrolyte level is higher than "lower level line." ○0 V when electrolyte level is lower than "lower level line."
Fuel gauge and low fuel warner	x 10 Ω	○One meter lead → White/yellow wire ○Other meter lead → Black/white wire	○1 — 117 Ω

Disassembly

.....
Clutch Release

- Refer to p. 9-35, noting the following.
- The positioning bolt for the clutch release shaft is added newly.

Clutch Release

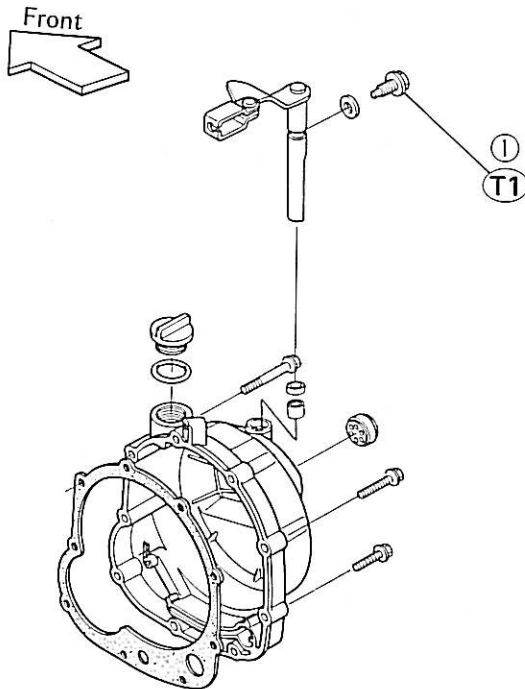

- 1. Positioning Bolt**
 T1: 6.9 N-m (0.70 kg-m, 61 in-lb)

Front Brake Disc

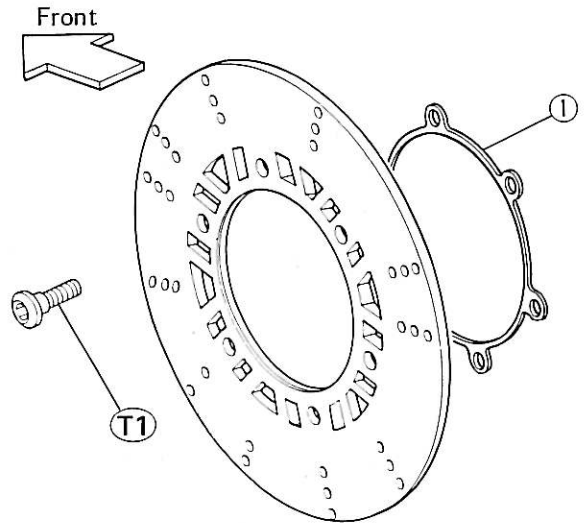

- 1. Shim**
 T1: 27 N-m (2.8 kg-m, 20 ft-lb)

- There is the shim between the front brake disc and the wheel rim.

.....
Brakes (ZX400)

Refer to p. 9-41, noting the following.

Supplement – 1986 – 1988 Models

This chapter, "Supplement-1986 – 1988 Models", are designed to be used in conjunction with the front part of this manual (up to the end of the chapter 10). The maintenance and repair procedures discribed in this chapter are only those that are unique to the 1986 through 1988 models. Complete and proper servicing of the 1986 through 1988 models therefore require mechanics to read both this chapter and the front part of this manual (up to the end of the chapter 10).

MODEL

'86 ZX550-A3	All information is the same as for the '85 ZX550-A2.
'87 ZX400-C3	All information is the same as for the '85 ZX400-C2.
'87 ZX550-A4	New carburetor is used on this model.
'88 ZX550-A5	All information is the same as for the '87 ZX550-A4.

Table of Contents

General Information	
Model Identification	11-2
Specifications (ZX550)	11-3
Service Data (ZX550)	11-5

General Information

.....
Model Identification
.....

ZX400-C3

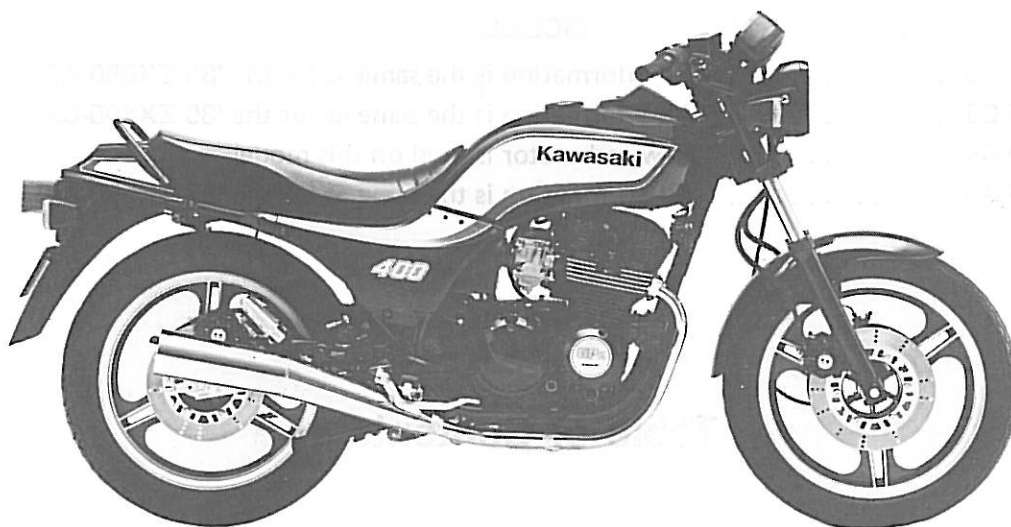

ZX550-A3, A4, A5

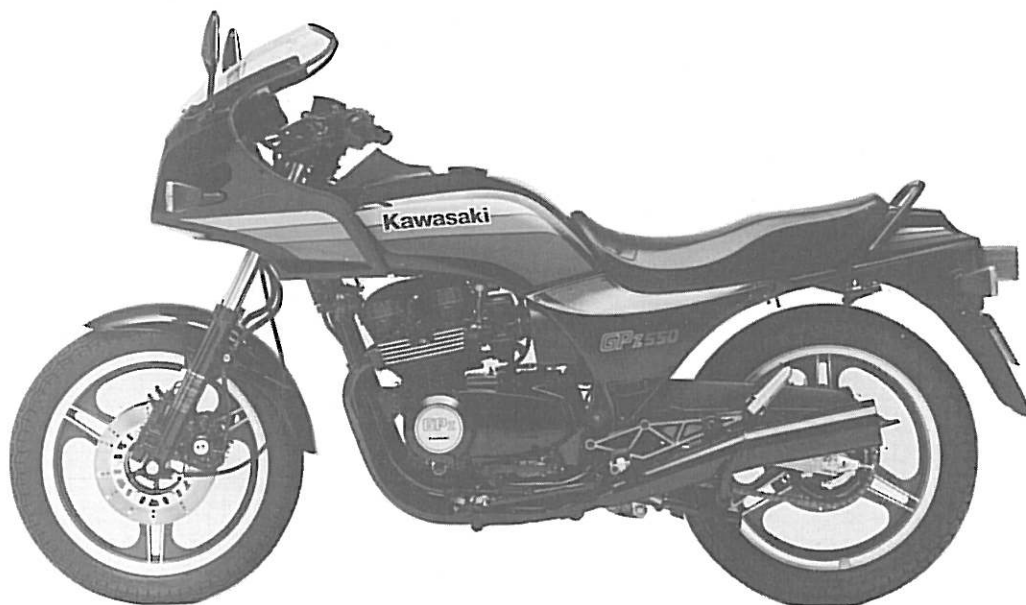

.....
Specifications (ZX550)

Items	ZX550-A3, A4, A5
Dimensions: Overall length Overall width Overall height Wheelbase Road clearance Seat height Dry weight Curb weight: Front Rear Fuel tank capacity	2,155 mm (A) (E) 2,205 mm 720 mm 1,245 mm 1,445 mm 160 mm 780 mm 1,870 N (191 kg) (C) 1,880 N (191.5 kg) 1,010 N (103 kg) (C) 1,020 N (103.5 kg) 1,040 N (106 kg) 18.0 L
Performance: Climbing ability Braking distance Minimum turning radius	30° 12 m from 50 km/h 2.5 m
Engine: Type Cooling system Bore and stroke Displacement Compression ratio Maximum horsepower Maximum torque Carburetion system Starting system Ignition system Timing advance Ignition timing Spark plug Cylinder numbering method Firing order Valve timing: Inlet Open Close Duration Exhaust Open Close Duration Lubrication system Engine Oil: Grade Viscosity Capacity	4-stroke, DOHC, 4-cylinder Air cooled 58.0 x 52.4 mm 553 mL 10.0 47.8 kW (65 PS) @10,500 r/min (rpm) (S) 37.5 kW (51 PS) @8,700 r/min (rpm) 48 N-m (4.9 kg-m, 35 ft-lb) @8,500 r/min (rpm) (S) 42 N-m (4.3 kg-m, 31 ft-lb) @8,000 r/min (rpm) Carburetors, TK K27V x 4, *KEIHIN CV30 x 4 Electric starter Battery and coil (transistorized) Electronically advanced From 12.5° BTDC @1,050 r/min (rpm) to 40° BTDC @10,000 r/min (rpm) (U) From 12.5° BTDC @1,200 r/min (rpm) to 40° BTDC @10,000 r/min (rpm) NGK DP9EA-9 or ND X27EP-U9 (CE) NGK DPR9EA-9 or ND X27EPR-U9 Left to right, 1-2-3-4 1.2-4-3 46° BTDC 54° ABDC 280° 64° BBDC 36° ATDC 280° Forced lubrication (wet sump with cooler) SE or SF class SAE 10W40, 10W50, 20W40, or 20W50 3.0 L

(Continued on next page.)

11-4 SUPPLEMENT—1986 — 1988 MODELS

Items	ZX550-A3, A4, A5
Drive Train:	
Primary reduction system:	
Type	Gear and chain
Reduction ratio	2.934 (27/23 x 65/26)
Clutch type	Wet multi disc
Transmission:	6-speed, constant mesh, return shift
Type	
Gear ratios:	
1st	2.571 (36/14)
2nd	1.777 (32/18)
3rd	1.380 (29/21)
4th	1.125 (27/24)
5th	0.961 (25/26)
6th	0.851 (23/27)
Final drive system:	
Type	Chain drive
Reduction ratio	2.375 (38/16)
Overall drive ratio	5.937 @Top gear
Frame:	
Type	Tubular, double cradle
Castor (rake angle)	26°
Trail	95 mm
Front tire:	
Type	Tubeless
Size	100/90-18 56H
Rear tire:	
Type	Tubeless
Size	120/80-18 62H
Front suspension:	
Type	Telescopic fork (pneumatic)
Wheel travel	160 mm
Rear suspension:	
Type	Swing arm (uni-trak)
Wheel travel	130 mm
Brake type:	
Front	Dual disc
Rear	Single disc
Electrical Equipment:	
Battery	12 V 12 AH
Headlight:	
Type	Semi-sealed beam
Bulb	12 V 60/55 W (quartz-halogen)
Trail/brake light	12 V 8/27 W x 2 (A) (E) 12 V 5/21 W x 2
Alternator:	
Type	Three-phase AC
Rated output	18.5 A @10,000 r/min (rpm), 14 V
Voltage regulator:	
Type	Short-circuit

Specifications subject to change without notice, and may not apply to every country.

(A) : Australian Model

(C) : US California Model

(E) : European Model

(S) : Swiss Model

(U) : US Model

(CE) : Canadian Model and European Model except Italian Model

* : ZX550-A4, A5

.....
Service Data

Refer to p. 1-12 - p. 1-16 and p. 10-5 noting the following.

Item	Standard	
	ZX550-A3	ZX550-A4, A5
Carburetors:		
Make, Type	TK, K27V	Keihin, CV30
Main jet	#114	#110
Main air jet	φ 1.0	#130
Jet needle	4A10	N16E
Jet needle clip position	Non-adjustable	←
Pilot jet	#34	#35
Pilot air jet	φ 1.25	#145
Pilot screw	2½ turns out, (W) 1¾ Ⓢ Ⓞ Non-adjustable	←
Service fuel level	7 ± 1 mm	-2.0 ± 1 mm
Float height	27 mm	16.5 mm

Supplement - 1991 Model

This chapter, "Supplement – 1991 Model", is designed to be used in conjunction with the front part of this manual (up to the end of the chapter 11). The maintenance and repair procedures described in this chapter are only those that are unique to the 1991 model. Complete and proper servicing of the 1991 model therefore requires mechanics to read both this chapter and the front part of this manual (up to the end of the chapter 11).

Table of Contents

General Information	12-2
Model Identification	12-2
Specifications (ZX400-C4)	12-3
Service Data (ZX400-C4)	12-5
Torque and Locking Agent (ZX400-C4)	12-5
Special Tools	12-6
Wiring Diagram (ZX400-C4)	12-6
Scheduled Maintenance	12-7
Throttle Grip (ZX400-C4)	12-7
Non-scheduled Maintenance	12-8
LCD Fuel Gauge and Warner Unit (ZX400-C4)	12-8
Disassembly	12-8
Carburetors (ZX400-C4)	12-8
Carburetor Holders (ZX400-C4)	12-9
Air Cleaner Housing (ZX400-C4)	12-9
Cylinder Head and Cylinder Rubber Dampers (ZX400-C4)	12-9
Camshaft Sprockets (ZX400-C4)	12-10
Clutch Release (ZX400-C4)	12-11
Clutch (ZX400-C4)	12-11

General Information

Model Identification

ZX400-C4

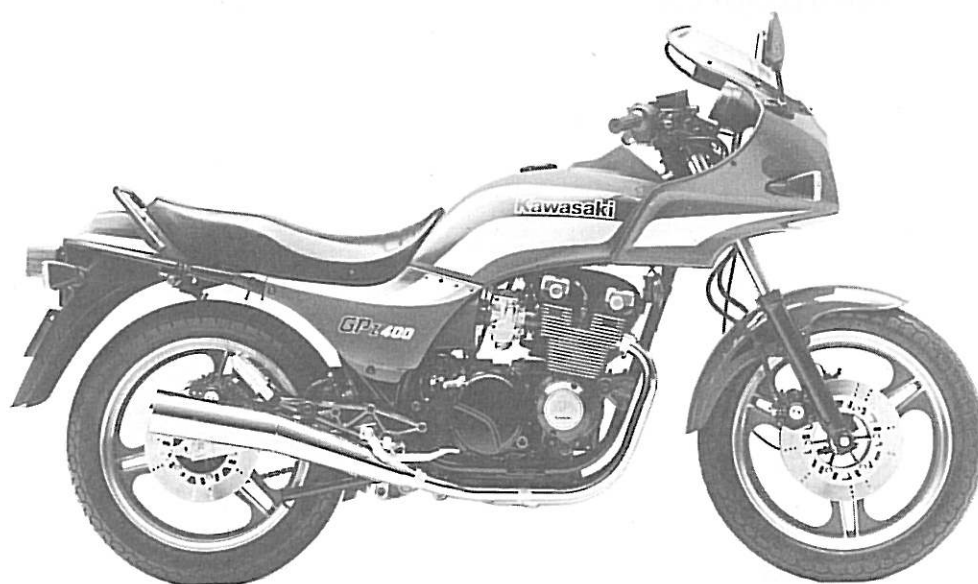
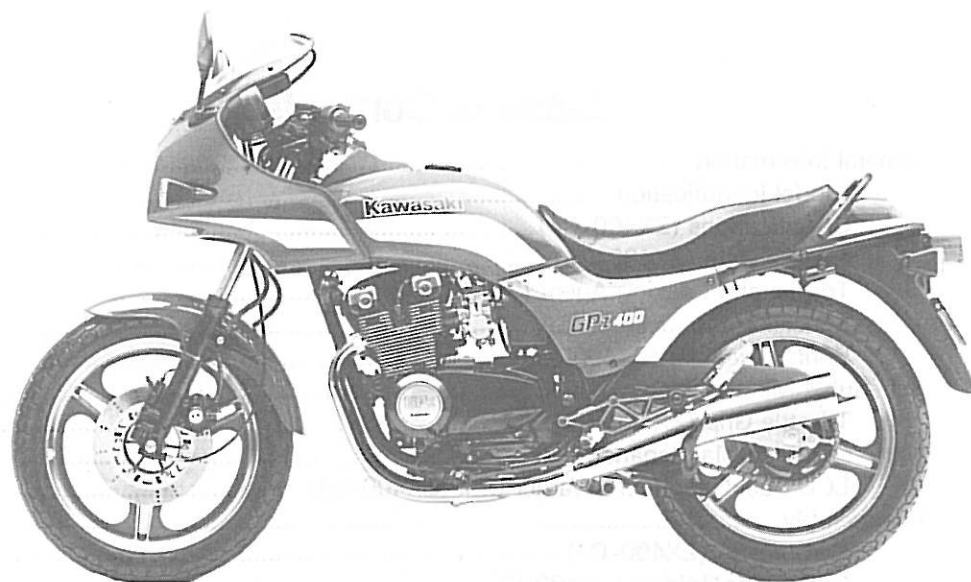

Specifications

Item	ZX400-C4
Dimensions:	
Overall length	2 180 mm
Overall width	720 mm
Overall height	1 245mm
Wheelbase	1 435 mm
Road clearance	160 mm
Seat height	780 mm
Dry weight	184 kg
Curb weight:	100 kg
Front	102 kg
Rear	
Fuel tank capacity	18.0 L
Performance:	
Minimum turning radius	2.5 m
Engine:	
Type	4-stroke, DOHC, 4-cylinder
Cooling system	Air-cooled
Bore and stroke	55.0 x 42.0 mm
Displacement	399 mL
Compression ratio	9.7
Maximum horsepower	40 kW (54 PS) @11 500 r/min (rpm)
Maximum torque	34 N-m (3.5 kg-m, 25 ft-lb) @9 500 r/min (rpm)
Carburetion system	Carburetors, Keihin CVK 30 x 4
Starting system	Electric starter
Ignition system	Battery and coil (transistorized)
Timing advance	Electronically advanced
Ignition timing	From 15° BTDC @1 200 r/min (rpm) to 40° BTDC @7 000 r/min (rpm)
Spark plug	NGK DPR9EA-9 or ND X27EPR-U9
Cylinder numbering method	Left to right, 1-2-3-4
Firing order	1-2-4-3
Valve timing:	
Inlet:	Open 46° (BTDC)
	Close 54° (ABDC)
	Duration 280°
Exhaust:	Open 64° (BBDC)
	Close 36° (ATDC)
	Duration 280°
Lubrication system	Forced lubrication (wet sump)
Engine oil:	Grade SE or SF class
	Viscosity SAE 10W-40, 10W-50, 20W-40, 20W-50
	Capacity 3.0 L

12-4 SUPPLEMENT - 1991 MODEL

Item	ZX400-C4
Drive Train:	
Primary reduction system:	
Type	Gear and chain
Reduction ratio	3.277 (27/23 x 67/24)
Clutch type	Wet multi disc
Transmission:	6-speed, constant mesh, return shift
Type	
Gear ratios:	
1st	2.571 (36/14)
2nd	1.777 (32/18)
3rd	1.380 (29/21)
4th	1.125 (27/24)
5th	0.961 (25/26)
6th	0.851 (23/27)
Final drive system:	
Type	Chain drive
Reduction ratio	2.625 (42/16)
Overall drive ratio	7.328 @Top gear
Frame:	
Type	Tubular, double cradle
Castor (rake angle)	25.5°
Trail	93 mm
Front tire:	
Type	Tubeless
Size	100/90-18 56H
Rear tire:	
Type	Tubeless
Size	110/90-18 61H
Front suspension:	Telescopic fork (pneumatic)
Type	
Wheel travel	160mm
Rear suspension:	Swing arm (uni-trak)
Type	
Wheel travel	130 mm
Brake type:	
Front	Dual disc
Rear	Single disc
Electrical Equipment:	
Battery	12 V 10 Ah
Headlight:	
Type	Semi-sealed beam
Bulb	12 V 60/55 W (quartz-halogen)
Tail/brake light	12 V 5/21 W x 2
Alternator:	Three-phase AC
Type	
Rated output	18.5 A @10 000 r/min (rpm), 14 V

Specifications subject to change without notice, and may not apply to every country.

Service Data (ZX400-C4)

Refer to p.1-12 ~ 1-16 and p.10-5 ~ 10-6, noting the following

Item	Standard								
Idle Speed: Idle speed	1 300 ±50 r/min (rpm)								
Carburetors: Make, Type Main jet Main air jet Jet needle Needle jet Pilot jet Pilot air jet Pilot screw Service fuel level Float height	Keihin, CVK30 #98 #100 N76R (#1, 4 Carburetors) N76Q (#2, 3 Carburetors) #6 #35 #150 1½ turns out -0.5 ±1 mm 17 mm								
Wheels: Tire air pressure	<table border="1" style="margin-left: auto; margin-right: auto;"> <tr> <td style="text-align: center;">Front</td> <td colspan="2" style="text-align: center;">196 kPa (2.0 kg/cm², 28 psi)</td> </tr> <tr> <td rowspan="2" style="text-align: center;">Rear</td> <td style="text-align: center;">Up to 956 N (97.5 kg) load</td> <td style="text-align: center;">221 kPa (2.25 kg/cm², 32 psi)</td> </tr> <tr> <td style="text-align: center;">956 ~ 1 790 N (97.5 ~ 183 kg) load</td> <td style="text-align: center;">245 kPa (2.50 kg/cm², 36 psi)</td> </tr> </table>	Front	196 kPa (2.0 kg/cm ² , 28 psi)		Rear	Up to 956 N (97.5 kg) load	221 kPa (2.25 kg/cm ² , 32 psi)	956 ~ 1 790 N (97.5 ~ 183 kg) load	245 kPa (2.50 kg/cm ² , 36 psi)
Front	196 kPa (2.0 kg/cm ² , 28 psi)								
Rear	Up to 956 N (97.5 kg) load	221 kPa (2.25 kg/cm ² , 32 psi)							
	956 ~ 1 790 N (97.5 ~ 183 kg) load	245 kPa (2.50 kg/cm ² , 36 psi)							

Torque and Locking Agent (ZX400-C4)

Refer to p.1-17 ~ 1-20 and p.9-14, noting the following.

Item	Torque			Remarks
	N-m	kg-m	ft-lb	
Cylinder Head: Carburetor holder bolts	12	1.2	104 in-lb	
Clutch: Clutch cover damper bolts	-	-	-	L

12-6 SUPPLEMENT - 1991 MODEL

Special Tools

Refer to p.1-21 ~ 1-26, noting the following.

- The following special tool is available for servicing of the cable lubrication.

K56019-021 : Pressure Cable Luber

- The following special tools can be used instead of the old parts.

New Parts		Old Parts
57001-1336	Piston Base	57001-149
57001-1041	Cam Damper Compressor, A	57001-297
57001-1243	Clutch Holder	57001-305
57001-1313	Flywheel Holder	57001-308
57001-1278	Oil Pressure Gauge Adapter	57001-403
57001-1242	Coil Tester	57001-980
57001-1219	Fork Oil Seal Driver	57001-1091
57001-1216	Rotor Puller	57001-1099
57001-1291	Vacuum Gauge & Tachometer	57001-1152

- The coil tester (57001-1242) can be used only for servicing of the ignition coil inspection.

Wiring Diagram (ZX400-C4)

The ZX400-C4 wiring diagram is the same as the ZX550A wiring diagram. Refer to p.9-16.

Scheduled Maintenance

Throttle Grip (ZX400-C4)

Adjustment

- Check the throttle grip free play.

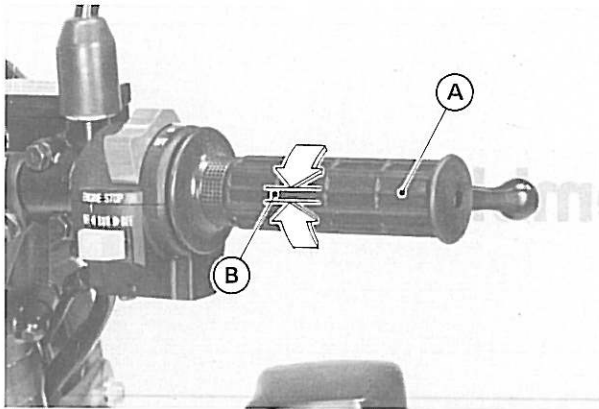

A. Throttle Grip

B. Throttle Grip Play

Throttle Grip Free Play

Standard: 2 ~ 3 mm

- ★ If the free play is incorrect, loosen the locknut and turn the adjuster of the accelerator cable until the proper amount of the throttle grip free play is obtained.

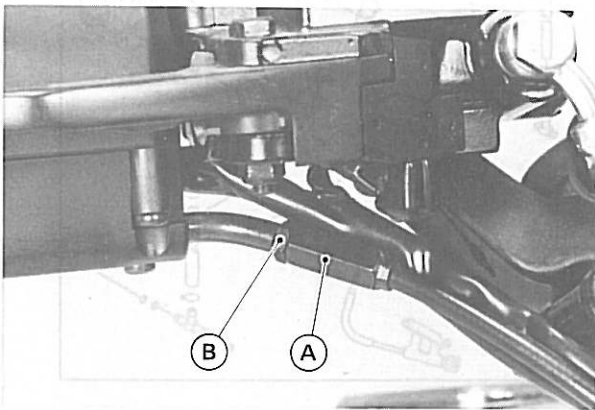

A. Adjusting Nut

B. Locknut

- Tighten the locknut against the adjuster securely.
- ★ If the play can not be adjusted by using the adjuster at the throttle grip, use the adjusters at the middle of the cables.
- Screw in the adjuster fully at the throttle grip and tighten the locknut.
- Remove the fuel tank.

- Loosen all the locknuts and turn the adjusters of the throttle cables until the proper amount of throttle grip play is obtained.
- Tighten the locknuts against the adjusters.
- Check that the throttle pulley stops against the idle adjusting screw with the throttle grip released and stops against the carburetor stopper with the throttle grip opened.

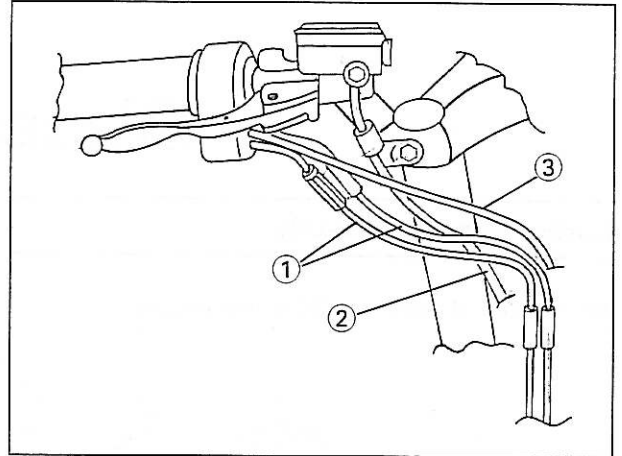

1. Throttle Cables
2. Brake Hose
3. RH Switch Leads

Non-scheduled Maintenance

LCD Fuel Gauge and Warner Unit (ZX400-C4)

The procedures for the LCD fuel gauge and warner unit servicing for ZX400-C4 is the same as those for ZX550A. Refer to p.9-31 ~ 9-33.

Disassembly

Carburetors (ZX400-C4)

● Carburetor of Keihin CVK30 is used on ZX400-C4.

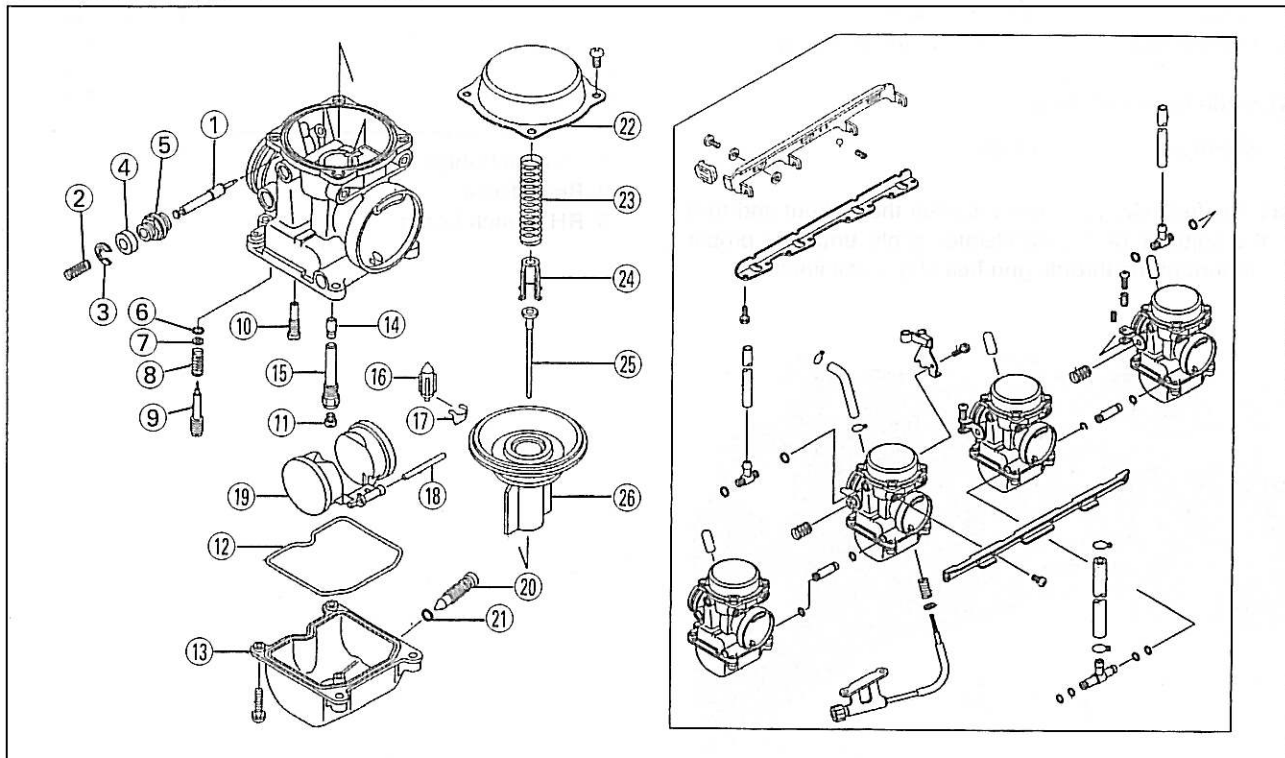

- 1. Starter Plunger
- 2. Spring
- 3. Circlip
- 4. Dust Cover
- 5. Cap
- 6. O-ring
- 7. Washer

- 8. Spring
- 9. Pilot Screw
- 10. Pilot Jet
- 11. Main Jet
- 12. O-ring
- 13. Float Bowl
- 14. Needle Jet

- 15. Needle Jet Holder
- 16. Float Valve Needle
- 17. Clip
- 18. Pin
- 19. Float
- 20. Drain Plug
- 21. O-ring

- 22. O-ring
- 23. Spring
- 24. Spring Seat
- 25. Jet Needle
- 26. Vacuum Piston and Diaphragm Assembly

Carburetor Holders (ZX400-C4)

- The left holder has an L mark and the right holder an R mark. Be careful not to mix them up.
- Tighten the holder bolts to the specified torque.
- Install the clamps as shown being careful of the screw position and the screw head direction.

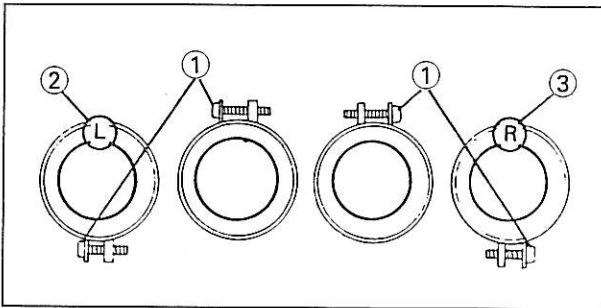

1. Screw Heads 3. R Mark
2. L Mark

⚠ WARNING

Be sure to install the holder clamp screws in the direction shown. Or, the screws could come in contact with the throttle linkage resulting in an unsafe riding condition.

Air Cleaner Housing (ZX400-C4)

- The silencer is installed in the air cleaner box.

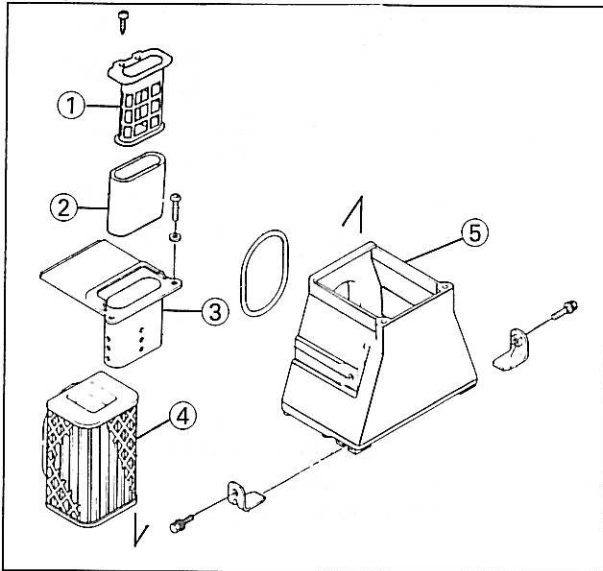

1. Silencer, in 4. Element
2. Silencer, out 5. Air Cleaner Housing
3. Air Cleaner Cap

Cylinder Head and Cylinder Rubber Dampers (ZX400-C4)

- Install the rubber dampers(4) between the cylinder head fins as shown.

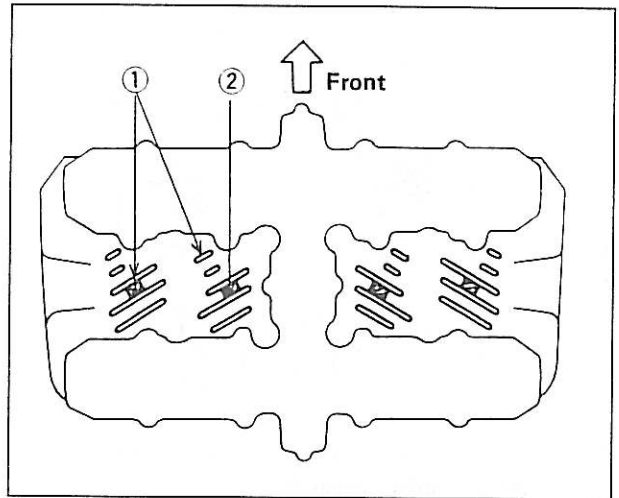

1. Cylinder Head Fins 2. Dampers

- Install the rubber dampers(16) between the cylinder fins as shown.

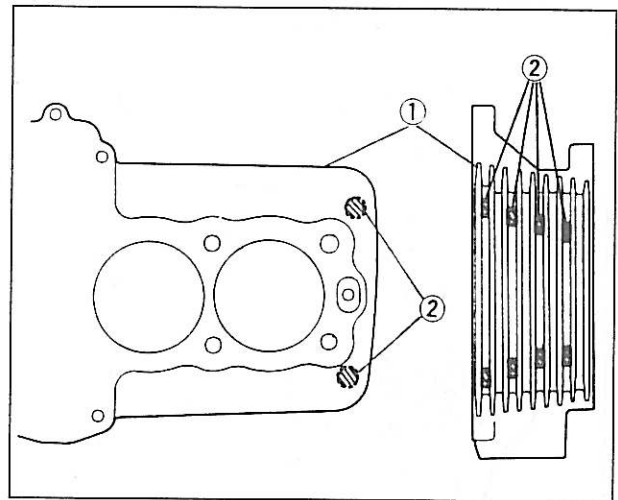

1. Cylinder Fins 2. Dampers

Clutch Release (ZX400-C4)

Release Shaft Removal

CAUTION

Do not remove the clutch release lever and shaft assembly unless it is absolutely necessary. If removed, oil seal replacement may be required.

- Remove the clutch cover.
- Do not loosen the clutch lever holder bolt.
- Pull the lever and shaft assembly out of the clutch cover.

Release Shaft Installation

- Apply high-temperature grease to the oil seal lips in the clutch cover.
- Apply oil to the bearing in the hole of the clutch cover.
- Apply oil to the release shaft.
- Install the clutch cover.
- Turning the release lever toward the rear, insert the release shaft straight into the upper hole of the clutch cover.

CAUTION

When inserting the release shaft, be careful not to remove the spring of the oil seal.

- Turn the release lever towards the front of the motorcycle until it becomes hard to turn.
- If the release lever was removed from the release shaft, install the lever aligning the split with the mark on the release shaft.

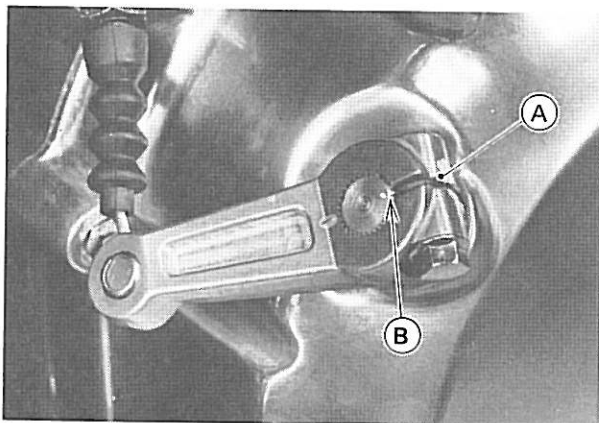

A. Split

B. Mark

Clutch (ZX400-C4)

- The grooves on the friction plate surfaces are cut tangentially and radially, install the friction plates so that the grooves run toward the center in the direction of the clutch housing rotation (counterclockwise viewed from the engine right side).

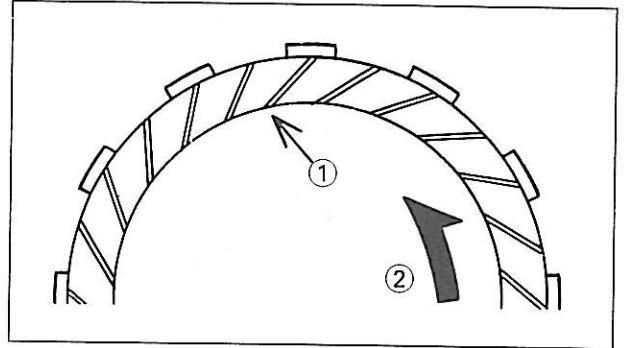

1. Groove

2. Direction of Rotation

MODEL APPLICATION

Year	Model	Beginning Frame Number
1983	ZR400-B1	ZR400A-000001
	ZR500-A1	ZR500A-000001
	ZR550-A1	ZR550A-000001
1984	ZR400-B1	ZR400B-000001
	ZR550-A2	ZR550A-002501
	ZX550-A1	ZX550A-000001 or JKAZXFA1 □EA000001
1985	ZX400-A3	ZX400A-011401
	ZX400-C2	ZX400C-000001
	ZX550-A2	ZX550A-009401 or JKAZXFA1 □FA009401
1986	ZX550-A3	ZX550A-013801
1987	ZX400-C3	ZX400C-000001
	ZX550-A4	ZX550A-015101
1988	ZX550-A5	ZX550A-016001
1991	ZX400-C4	ZX400C-010001

□ : This digit in the frame number changes from one machine to another.

KAWASAKI
HEAVY INDUSTRIES, LTD.
 CONSUMER PRODUCTS & COMPONENTS GROUP

6FC065 1
 99924-1040-05
 SER. MAN. SUPP., ZR550B
 9711000 5297931
 16.57.45 0371

Part No. 99924-1040-05

Printed in Japan